



National Headquarters

Level 12
80 The Terrace
PO Box 2133
Wellington
New Zealand

Phone +64 4 496 3600

31 August 2022

Matthew Maxwell

By email: fyi-request-20272-790ce165@requests.fyi.org.nz

Tēnā koe Matthew

Information Request – Study Guide / Operator's Manual

I refer to your official information request dated 18 August 2022 asking for the operation manual and study guide for the Type 4 heavy pump aerial truck.

Thank you for confirming on 26 August 2022 that the Operator's Manual you require is "for the truck itself including the aerial function."

In accordance with the provisions of the Official Information Act 1982, I *enclose* the study guide for the Type 4 Bronto F17 CTL (Scania 4 Series & P Series).

We have determined that the Operator's Manual in-scope of your request is for the Bronto Skylift F17CTL. We can provide access to the Operators Manual. However, as you have been previously advised, there is only a hardcopy available. This is held at the Fire Stations where Type 4 appliances are based. The reason why electronic copies are not accessible are because manuals are made unit specific which means some functions, controls etc are not provided on all units of the same build. Manufacturers therefore do not recommend we create electronic copies of their manuals.

We can arrange for you to view the Bronto Skylift F17CTL Operator's Manual at a Fire Station that holds a Type 4 appliance nearest to you. Please let us know the area in which you are based so we can arrange this.

We contacted the Technical and Training Manager at Bronto Skylift about your request. He has offered to speak to you to see if he can address any questions you have. Please let us know if you would like to take up this offer.

You have the right to seek an investigation and review by the Ombudsman of this decision. Information about how to make a complaint is available at www.ombudsman.parliament.nz or freephone 0800 802 602.

Nāku noa nā



Julia McCook-Weir
Manager, Information Requests

encl





learning station >>>

Name:

Station:

Rank:

Type 4 Bronto

F17 CTL

(Scania 4 Series & P Series)

Study guide



Status of this document

This document is issued by Fire and Emergency New Zealand.

Recommendations for change:

Training encourages and welcomes feedback on all our materials.

Recommendations for changes to this material should be sent to Training using the Training Feedback Form on The Portal.

For the most up-to-date information, please refer to The Portal.

Document title:

Type 4 Bronto F17 CTL
(Scania 4 Series & P Series)
Study Guide

Published:

August 2011

Amended:

July 2016

January 2021

Disclaimer

This content contains Fire and Emergency New Zealand training material which has been developed to guide and support firefighters working for Fire and Emergency New Zealand and partner agencies only.

Fire and Emergency New Zealand makes no representation as to the appropriateness, effectiveness or safety of this material for anyone other than authorised Fire and Emergency New Zealand or partner agency personnel. Fire and Emergency New Zealand will not be responsible or liable for any outcome caused by unauthorised reliance on this material.

© Fire and Emergency New Zealand - Training

If you wish to copy or reproduce any of the material in this document, please contact:

Team Leader, Learning and Development
Training
PO Box 2133
Wellington 6140

Contents

Contents	1
Course information.....	3
Learning outcomes	3
Course duration.....	4
Course delivery	5
Driving qualifications	5
Course assessment and completion.....	5
Course materials	5
Section 1: Introduction.....	7
References	7
Responsibilities	9
Appliance views.....	11
Section 2: Driving and siting.....	13
Safety alerts.....	13
Technical information.....	13
Driving	16
Siting the appliance	23
Appliance maintenance	27
Section 3: Pump operation	29
Safety alerts.....	29
Pump technical information.....	29
Pump panel overview	30
Main pump operation	31
High-pressure pump (HP) operation.....	32
FoamPro system	35
Section 4: Aerial operation.....	39
Safety	39
Technical information.....	39
Levelling the appliance	40

Boom operation 50
Aerial ladder 58
Fall restraint 60
Aerial monitor system 62

Appendix 1: Darley PSP and auto-presssure. 64

Appendix 2: Hand signals 93

Released under the Official Information Act 1982

Course information

Learning outcomes

During the course evidence will be collected to show you can:

- describe safe and efficient operation of the aerial appliance
- drive the appliance in transit correctly and safely
- site the appliance at an incident area to achieve optimal performance of the aerial ladder
- stabilise the appliance using the outriggers and jacks prior to aerial operation
- operate the aerial ladder to achieve given objectives efficiently
- manoeuvre the aerial monitor to achieve given objectives efficiently.

Course duration

It is expected that you will complete your aerial appliance training within a three month period.

Released under the Official Information Act 1982

Course content

The course has both practical and theory sessions, but it is predominantly hands on.

The following is a list of the course topics:

- Topic 1: Introduction
- Topic 2: Responsibilities
- Topic 3: Technical data
- Topic 4: Cab layout and appliance walk around (includes a driver training component)
- Topic 5: Routine checks (includes a driver training component)
- Topic 6: Siting theory
- Topic 7: Practical outrigger operation
- Topic 8: Practical operation of aerial: Part 1
- Topic 9: Practical operation of aerial: Part 2
- Topic 10: Levelling - sloping and uneven ground
- Topic 11: Driving the appliance: Practical operation city streets and buildings (includes a driver training component)
- Topic 12: Rescues
- Topic 13: Emergency systems
- Topic 14: Water tower
- Topic 15: Practical drills under assessment conditions
- Topic 16: Theory assessment
- Topic 17: Practical assessment
- Topic 18: Course wrap up

Course delivery

It is most likely your training will be done on shift, rather than as black watch training.

Driving qualifications

If you are a Grade 2 brigade driver, you will need to complete a driving assessment to become a Grade 1 driver. This assessment will be carried out by a FENZ driving instructor.

Course assessment and completion

To successfully complete the course you must pass written and practical assessments related to the operation of the Bronto F17 CTL.

If you are assessed as not yet competent on a component, or components of the practical course, you will be given the opportunity to be assessed by a different assessor. You are expected to re-sit the test within four weeks of not passing.

The minimum pass rate for the written (theory) assessment is 80%.

Course materials

Study guide

This study guide covers the skills and knowledge required to operate both the Type 4 Bronto F17 CTL P Series and the Type 4 Bronto F17 CTL 4 Series safely and following set procedures.

This study guide contains information pertaining to the overall operation of the Type 4 appliances in general, through to detailed notes on the operation of the Bronto F17 CTL 4 Series and P Series aerial ladder.

4 Series and P Series content differences

A yellow line in the left hand margin of a page indicates that the adjacent text and/or images covers differences between the Scania 4 Series and Scania P Series.

Note

The components of the Type 4 Appliance photographed in this study guide may differ slightly from the configuration on your actual Type 4 Appliance. Each appliance may have subtle variances due to manufacturer upgrades between the purchase of new vehicles.

Student workbook

The workbook supports your practical training, and reinforces the knowledge you need to safely and effectively operate the Type 4 aerial appliance.

The workbook is a learning tool, not an assessment. As such it will not be collected in as evidence of your learning.

You are expected to complete relevant sections of the workbook as you go through your training. See your trainer if you would like help to check the accuracy of your answers or if there is anything in the workbook you are unsure of.

Released under the Official Information Act 1982

Section 1: Introduction

References

The material contained within this study guide has been drawn from a number of sources. Only information directly relevant to this course has been included.

Fleet Operational Instructions

FL1 Driving

The driving of Fire and Emergency New Zealand (FENZ) appliances is covered by FL1 Driving. FL1 should be reviewed by all drivers and officers as part of your training.

FL1 provides instructions for driving FENZ operational vehicles, and includes information on safety requirements.

A Type 4 Appliance (greater than 14,000kg heavy pump elevating monitor – Urban) has the same maximum speed limits as the more familiar Type 3 appliances as opposed to those limits set for the Type 5 Appliances (Aerial).

If you are a Grade Two driver moving to this appliance, you will be required to complete an advanced driver assessment as well as completing this training. Once qualified, you will be appointed as a Grade One Driver.

Incident Safety - Operational Instructions

You should read Working near roadways (IS3) and its related topics in conjunction with this study guide. IS3 relates to hazard identification and best practice procedures when operating appliances on roadways.

Working at heights (IS2)

This policy and its related topics should be read in conjunction with this study guide. B.1 Working at Heights relates to the Health and Safety in Employment (HSE) Regulations 1995 clause 21, which requires every employer to take all practicable steps to ensure fall protection is provided where an employee may fall more than three metres.

In order to comply with Health & Safety in Employment (HSE) Regulations 1995 and FENZ Operational Policy, all operators of the Type 4 Appliance are to be trained in the operation and use of fall restraint harness and related equipment. This training is to be conducted prior to conducting any operations

Link

Working at heights (IS2) is located on The Portal within incident safety.

requiring the aerial ladder operator to work from the head of the ladder. This also includes any firefighter (not just the operator) that is required to work from the standing platform at the head of the ladder.

Working near electrical hazards (IS4)

For electrical safety practices, refer to the Operational Instruction Working near electrical hazards (IS4). This should be read in conjunction with this study guide.

Code of practice

NZ Electrical Code of Practice for Electrical Safe Distances 2001 (NZCEP 34:2001)

This code states:

“The minimum approach distance between any live overhead electric cable and any part of a mobile plant (Type 4 Appliance) is to be “AT LEAST 4.0 METRES”.

This minimum distance can be reduced in emergency situations provided the following criteria is met:

- The operator of the Type 4 Appliance is trained and qualified to competently operate the aerial ladder
- An emergency situation exists that warrants the added risk of reducing the minimum approach distance
- The reduced minimum approach distances must not be less than those listed within the NZCEP 34: 2001.

The minimum approach distances specified by Fire and Emergency meet these criteria, and are specified in the table Section 2 - Driving.

Aerial appliance - safe use and minimum maintenance

The Australian Fire Authorities Council (AFAC) committee has prepared a code of practice relating to the Aerial Appliance - Safe use and minimum maintenance.

This code of practice has been developed expressly for fire service aerial appliances and covers minimum maintenance requirements and operational use safety information.

Link

For more information on overhead wires, refer to “Approach distance for overhead cables, Section 2 Driving and Siting” of this study guide.

Link

NZCEP 34: 2001 is on The Portal.

Manufacturers' manuals

Operational and Maintenance Manual for Fire and Emergency Type 4 Heavy Aerial Pump Appliance

This manual, which is divided into sections, contains manufacture specific information regarding operator use and servicing details for the major separate components of the appliance. This manual also refers users to other manufacturers manuals for the following major components of the appliance:

- Bronto Skylift F 17 CTL/Allrounder Manual
- Scania Drivers Instructions
- Darley Pump.

Bronto Skylift F17CTL/Allrounder Manual

This manual contains information specific to the Bronto aerial ladder such as:

- warranty terms
- safety instructions
- operating instructions
- service instructions
- hydraulic system
- electrical system
- spare parts
- firefighting equipment.

Scania Drivers' instructions

This manual contains information specific to the pump:

- safety instructions
- operating instructions
- service instructions.

Link

Bronto website:
www.bronto.fi

Link

Scania website:
www.wsdarley.com

Responsibilities

Employer's responsibilities

Chief Fire Officers must ensure:

- the aerial is operated by competent operators and is used in accordance with the operating instructions
- appropriate documentation and records are maintained
- the appliance is inspected regularly, repaired and maintained by those competent to carry out such work and that periodic testing is carried out.

Operator's responsibilities

- Operate the work platform safely and in accordance with the operating instructions.
- Carry out daily maintenance checks.
- Do not exceed the Safe Working Load (SWL) of the platform.
- Operate the appliance so as not to cause harm to themselves or any other person.
- Never approach within the minimum approach distance of overhead powerlines.
- Do not exceed posted speed limits as detailed in FL1 SCa Schedule of permitted speeds to incidents.
- Only operate the boom under the direction of any person at the head.

Appliance views

Full details of the major components; vehicle, body, pump and aerial ladder can be found in the Fraser Fire Operational and Maintenance folder and the Bronto manufacturer's manual.

Note

Variations may occur on some appliances.

4 Series



P Series



Section 2: Driving and siting

Safety alerts

The following notes are general safety notes pertaining to this appliance; they are not intended to fulfil the requirements of the Emergency Response Driver training for this appliance.

Make up to road worthiness

Before moving from an incident site, observe the following points.

1. Verify that the Bronto Skylift unit is completely in its transport position.
2. Monitor is returned to transport position.
3. Ensure all aerial's make-up functions are fully completed and all warning lights show correct placement.
4. All switches are returned to road position.
5. The front axle brake switch is in the safety off position.
6. All equipment is stowed in lockers.
7. All lockers and steps are closed.
8. The Aerial/HP Power Take-off (PTO) must be disengaged.
9. Check any warning lights of the outriggers, booms, lockers, and PTO are not illuminated before driving away.

Operating on a public road

When operating the appliance on a public road the operator must:

- operate flashing beacons
- operate hazard lights
- ensure jack hazard lights are operating
- ensure road cones are placed so as to provide a safe working area.

Alert

Due to the weight of this vehicle, drivers must take care when braking and cornering to ensure the vehicle is driven to the road and weather conditions.

Technical information

The provisional laden and tare weights requires drivers to hold a class 4 licence in accordance with Schedule 3 of the Land Transport (Driver Licensing) Rule 1999.

Cab and chassis

Manufacturer and type

Scania 4 Series: C30 420

Scania P Series: P420 LB 6x4 MNA

- 6x4 with differential lock fitted for driving rear axle
- single steer front axle with Super Single tyres
- tandem drive dual wheel rear axles fitted with standard tyres
- airbag suspension, adjustable from the drivers position via a remote control
- Cruise control

Dimensions

Overall length.....	9.3m
Overall width (excluding mirrors).....	2.5m
Overall height.....	3.6m
Gross Vehicle Weight (GVW) (fully operational c/w crew of five)	22 tonnes

Engine

Scania, 6 cylinder diesel, 11.7 litre, turbo charged, intercooler, 420BHP

Transmission

Allison automatic transmission (reprogrammed back to 5 speeds with hydraulic braking retarder).

Tyres and pressure

Front:	97psi (670kpa)
Rear:	85psi (586kpa)

Brakes

Wheel brakes

Disc brakes are fitted to all wheels.

Anti-locking braking system (ABS)

The ABS compares the speed of each wheel and adapts braking power accordingly so that no wheel locks up. The advantages of ABS are:

- shortest possible stopping distances without loss of steering and directional stability
- reduced risk of accidents on slippery roads
- reduced tyre wear.

An independent front axle brake independently locks the front brakes during aerial ladder operations. The switch is located in the rear control locker and is fitted with a safety cover to prevent accidental application.

Exhaust brakes

An engine exhaust brake is fitted. This brake assists vehicle braking and reduces the stress on the normal braking system. The exhaust brake prevents normal exhaust gases from escaping the engine, therefore creating back pressure throughout the system.

Retarder

The retarder is a hydraulic brake driven by the transmission output shaft. It is used to supplement the regular brake system and to control downhill speed.

Alert

Do not accelerate and brake at the same time while the exhaust brake is engaged. Doing so can cause damage through over-pressurising the engine.

Body work

Manufacturer

Fraser Fire & Rescue Ltd, Lower Hutt

Water tank capacity.....1440 litres (4 Series)
1350 litres (P Series)

Class A Foam tank capacity (useable).....60 litres

Features

The Type 4 Appliance has a larger than normal crew cab and offers locker stowage similar in layout and quantity to that of a Type 3 pump.

Driving

Cab layout (4 Series)

The following figures show only those controls/switches that may be different to a standard Scania cab. Full details of factory Scania cab layout can be found in the Scania Manual.

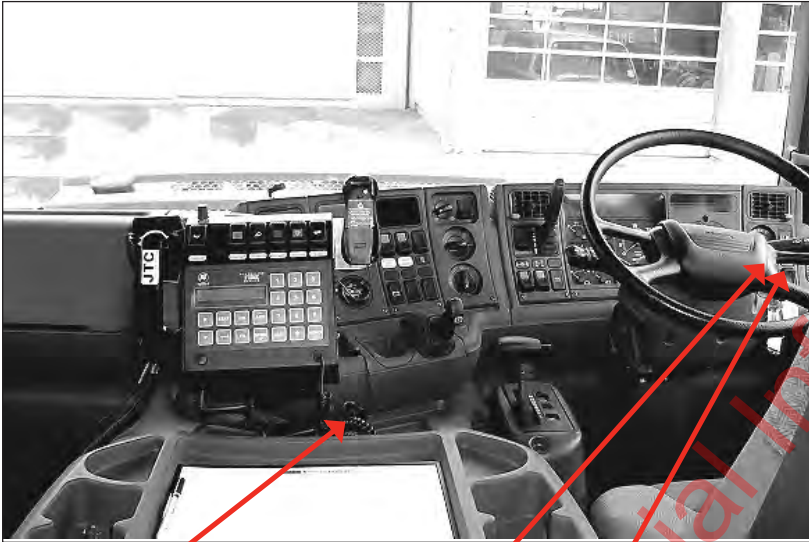

Brake reset button

Diff lock and retarder control



Brake reset button

If air pressure is low the brakes will lock on and this knob will pop out. Push knob in to reset brakes.

Cab layout (P Series)

The following figures show only those controls/switches that may be different to a standard Scania cab. Full details of factory Scania cab layout can be found in the Scania Manual.



Diff lock and retarder control



Inhibit override

The engine will not start with a 230v supply connected to the appliance. Disconnect the supply or pull this button to enable starting

Rear axle diff locks

The left hand switch will lock the differentials for increased traction when manoeuvring slowly on slippery surfaces.

Note: The diff lock on the rear axle of the tandem bogie will only engage if the tandem bogie lock is also activated.

⚠ Alert

Only operate the differential locks when traction is likely to be lost at the rear axle.

The vehicle must be stationary before operating either lock.

The diff lock will cause difficulties with steering.

Damage can occur to the driveline if either lock is left activated when driven on a normal road surface.

Retarder controls (4 Series)

The retarder is a hydraulic brake driven by the transmission output shaft. It is used to supplement the regular brake system and to control downhill speed.

The retarder is activated when the throttle is released.

The six-position stalk lever sets the degree of braking effect and controls braking and downhill speed.

1. In the uppermost position, the retarder is off.
2. The lowest position gives the maximum braking effect.

The retarder can also be activated with the brake pedal.

The three position switch controls when the retarder will operate:

1. Upper position: Retarder off
2. Middle position: Retarder effect 30%
3. Lower position: Retarder effect 60%

The ABS system will disengage the retarder to prevent wheel lock during braking.

Alert

Disengage the retarder when driving on slippery roads.

The retarder generates a lot of heat and braking effect will be automatically reduced to prevent overheating. If the gearbox oil temperature warning lamp comes on, you must reduce speed or use the lever to apply less braking effect.

Retarder controls (P Series)

The retarder is a hydraulic brake driven by the transmission output shaft. It is used to supplement the regular brake system and to control downhill speed.



Operation

- AUT button in position '0' lever all the way up = retarder off
- AUT button in position '0' and the foot is lifted off the accelerator pedal:
 - lever down 1 notch = 20% retarder.
 - lever down 2 notches = 40% retarder.
 - lever down 3 notches = 60% retarder.
 - lever down 4 notches = 80% retarder.
 - lever down 5 notches = 100% retarder.
- AUT button in position '1' lever all the way up = retarder working when foot brake is applied:
 - Electronic Braking System (EBS) calculates and applies the amount of retarder needed, ie in an emergency braking situation where the foot brake is applied quickly, up to 100% retarder could be applied as well as the exhaust brake if required.
 - In light braking situations the retarder could be applied around 20-40%; this is also managed by EBS.

Note

The ABS system will disengage the retarder to prevent wheel lock during braking.

- AUT button in position '1' lever down and the foot is lifted off the accelerator pedal the following amount of retarder is applied:
 - lever down 1 notch = 20% retarder.
 - lever down 2 notches = 40% retarder.
 - lever down 3 notches = 60% retarder.
 - lever down 4 notches = 80% retarder.
 - lever down 5 notches = 100% retarder.

Alert

Disengage the retarder when driving on slippery roads.

The retarder generates a lot of heat and braking effect will be automatically reduced to prevent overheating. If the gearbox oil temperature warning lamp comes on you must reduce speed or use the lever to apply less braking effect.

Warning for increased overhangs

Increased overhang, particularly at the rear, must be considered at all times. In narrow intersections the driver must confirm that there is enough space for turning.

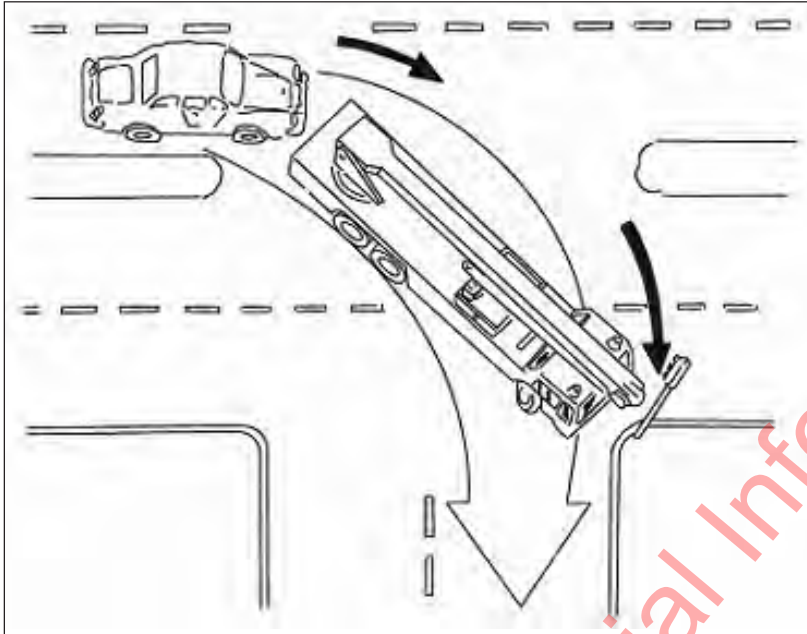

Consider vehicle length at intersections
(Source: Bronto Skylift, 2003)

If the appliance is required to leave a formed road consider the ground clearance to the front and rear of the appliance as well as the ground conditions.

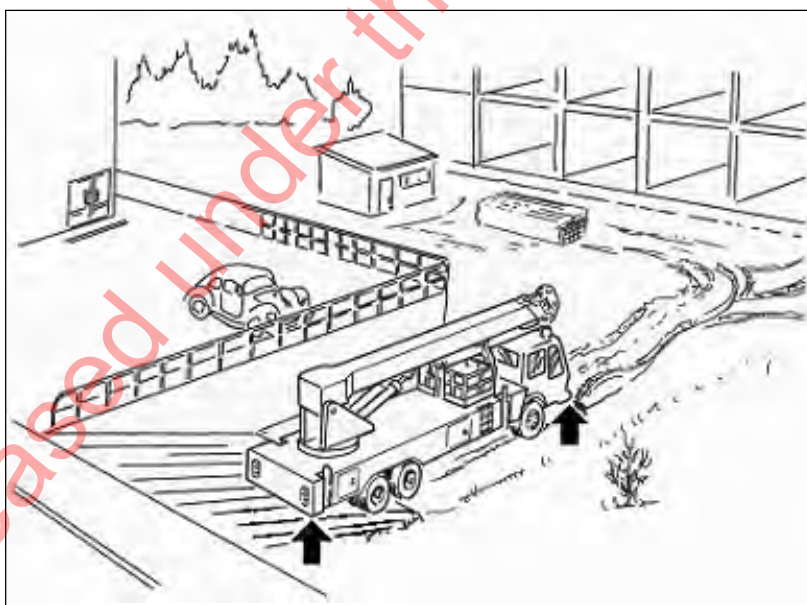

Consider ground clearances
(Source: Bronto Skylift, 2003)

Warning for high centre of gravity and appliance height

The increase in the height of the centre of gravity for this appliance creates a greater amount of body roll than smaller appliances while cornering.



Never speed when cornering
(Source: Bronto Skylift, 2003)

The driver must confirm that the vehicle can freely pass low underpasses, remember appliance height is 3.6m.

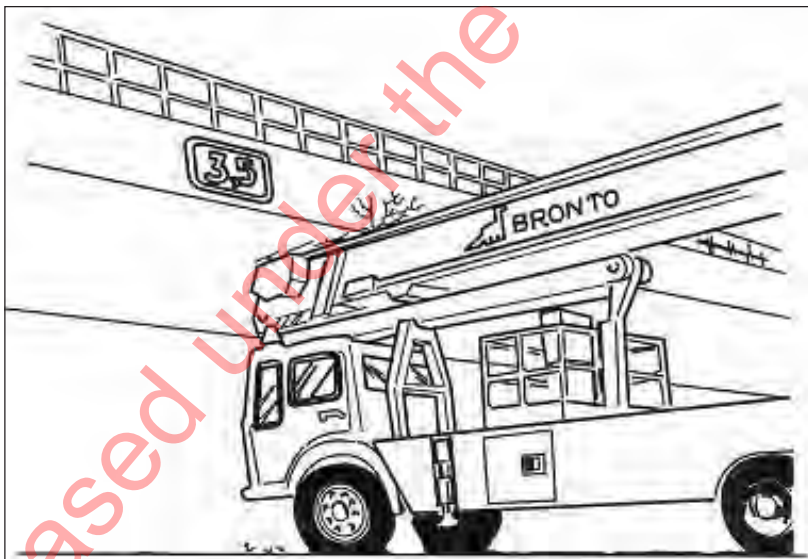

Consider vehicle height
(Source: Bronto Skylift, 2003)

Siting the appliance

Siting responsibilities

The Incident Controller (IC) is responsible for deciding when and where an aerial will be used.

The OIC of the aerial is responsible for siting the aerial within its operating range for the objectives given.

General rules

The following must be considered when assessing options for appliance siting at incidents.

- Ensure safety of personal on and around the aerial.
- Ensure the safety of the appliance and aerial.
- Ensure enough room for full jacking.
- Use the outreach diagram to ensure the objective can be reached.
- If the appliance must be placed close to a building then it should be reversed in – this will ensure optimum elevation and reach can be achieved.

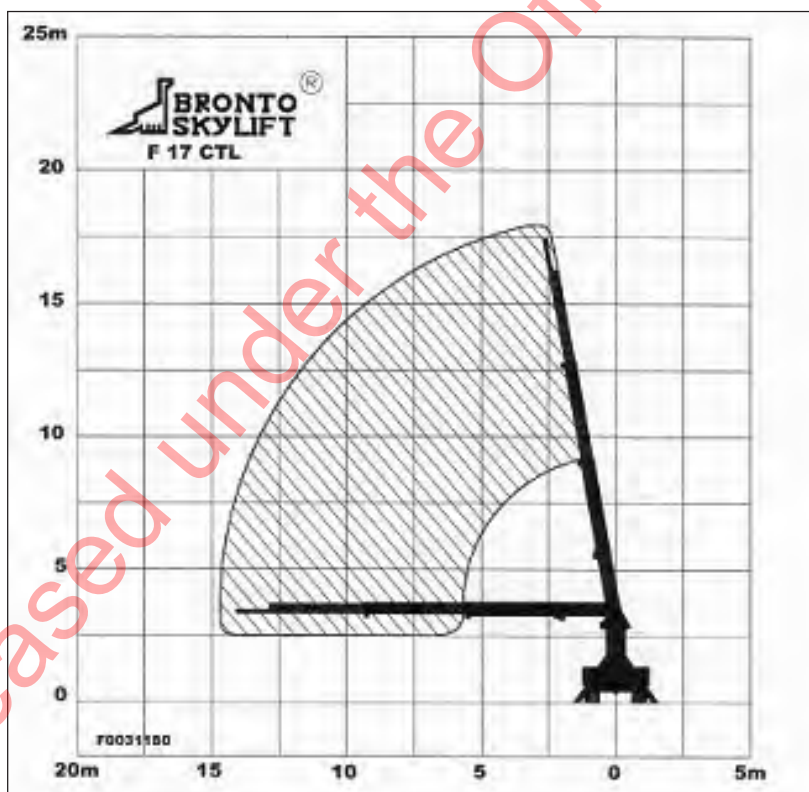

Bronto F17 CTL Outreach
(Source: Bronto Skylift, 2003)

Ground

When siting, consideration must be given to the risks associated with placing jacks near or on:

- manhole covers
- soft ground
- drains, pipes, underground tanks
- unsealed roads
- cracks and joins
- concrete curbing and footpaths.

Gradient

- Bronto appliance is always sited facing downhill.
- Ensure the gradient is no more than a maximum of 7 degrees.

Obstructions

Be aware of obstructions above the boom that may hinder or stop the aerial from reaching its objective. Such obstructions are:

- wires
- poles
- signs
- fire escapes
- verandas.

Hazards

Action must be taken to minimise the risks associated with known hazards.

Exposure hazard:

Radiant heat or direct flame may cause damage to the aerial. To minimise the risk, site the aerial so it is not exposed to high levels of radiated heat or direct flame that may cause harm to the operators or damage to the aerial.

Building collapse:

Badly damaged buildings could collapse. To minimise the risk, keep a careful watch on walls for signs of collapse. Operating at a corner offers greater protection from building collapse (This position also offers greater area of achievement for an aerial). Large quantities of water may also contribute to structural failure.

Wind hazard:

Wind velocity may vary greatly at different heights. The greater the extension, the greater the effects of wind on stability. To minimise the risk, always operate within the safe wind speed rating of 45km/hr.

Flying debris hazard:

Be aware of the potential for flying glass, dislodged roofing and hot brands or hot embers. Position the appliance to minimise the risk of being hit.

'People' hazard:

Persons awaiting rescue may fall or jump onto the aerial causing shock loading. When using the aerial for rescue, approach the head from above or from the side to eliminate the chance of this happening.

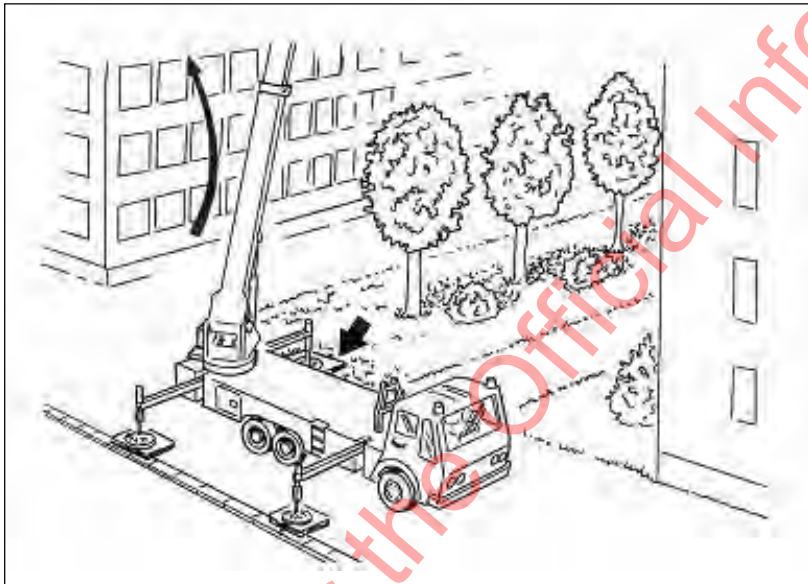

Siting considerations

(Source: Bronto Skylift F32 RLH Operating Manual 1996)

Approach distance for overhead cables

Non-emergency situations

The distance between any live overhead electric line and any part of any mobile plant or load carried must be AT LEAST 4.0 METRES, unless an emergency situation warrants working at reduced distances.

Emergency situations

The authorised reduced distances between an overhead power cable and an aerial appliance (operated by a competent employee) in an emergency situation are shown below. These distances meet or exceed the NZ Electrical Code of Practice for Electrical Safe Distances and must be observed.

Voltage	Minimum safe distance
Not exceeding 66kV	1m
Exceeding 66kV but not exceeding 220kV	2.5m
Exceeding 220kV	4m
Voltage unknown	4m

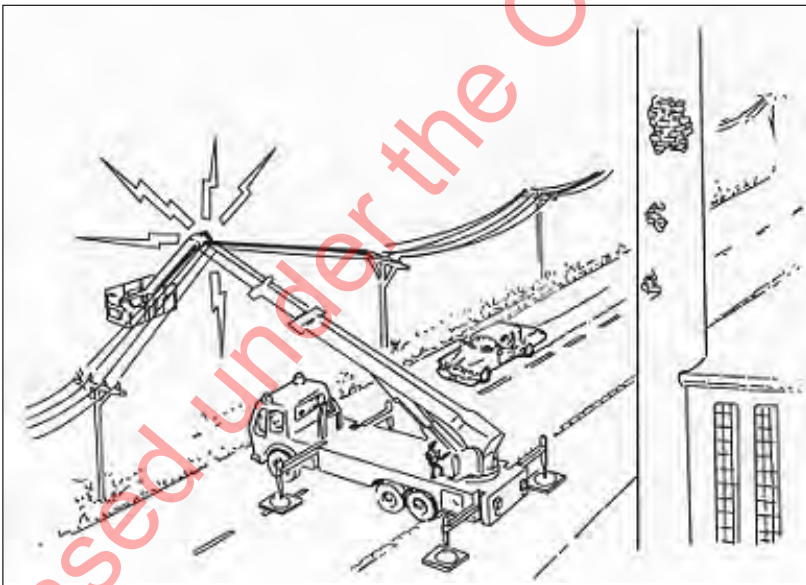

Observe minimum safe distances
(Source: Bronto Skylift, 2003)

Warning decal requirements

To conform with the electrical code of practice, and health and safety requirements a decal stating: "WARNING, KEEP CLEAR OF POWER LINES" must be affixed in a conspicuous place as near as practicable to the operator's position. The decal is to be maintained in a legible condition.

Alert

As this appliance is not insulated or earthed for work in contact with power lines, these limits must be strictly observed.

Appliance maintenance

Daily checks

The following checks should be completed daily and any faults noted on the daily inspection sheet. Faults must also be reported following normal station processes.

- Drivers checks: fuel, oil, water levels, appliance lights, emergency response lighting, distance licence etc.
- Equipment checks - All equipment present and stowed correctly.
- BA Cylinder bulk air supply contents and airline connections (when fitted).
- Visual inspection appliance and aerial components - Hydraulic fluid leaks, oil/water leaks, security of fittings, pipe work, cables and catches, creeping jacks.
- Record and report any defects or faults.

Link

The career appliance daily checklist (FL7 FLM) is available on The Portal.

Weekly checks

The following additional checks are to be carried out on this appliance weekly.

- Check operation of emergency stop buttons. Ensure buttons lock in the up position.
- Check operation of all warning lights, instruments and signal horn.
- Visual inspection of rotation ring screws for looseness.
- Elevate and extend fully, rotate through 360 degrees.
- Check operation of all functions and dead man throttle switch.
- Check operation of boom safety limits.
- Check operation of emergency lowering control.
- Check operation of emergency battery powered hydraulic pump (8 minutes max use with 5 minute rest cycle).

- Boom extended and horizontal, carry out visual inspection of boom components, pins, security of attachments, fastening of ladder and components. Inspect general condition. Pay particular attention to cracks in paintwork and security of bolts, cable and wiring for damage etc.
- Visual inspection of ladder chains and cable mechanism.
- Observe if any creepage obvious from jacks.
- Check and record hour meter hours in logbook. Note: Lubrication of Aerial required at 50 hour/quarterly intervals, whichever ever occurs first (lubrication carried out by Service Provider).
- Check operation of front axle brake.
- Check operation of intercom.
- Check operation of monitor movements.
- Record and report any defects or faults.

Additional quarterly and annual servicing

All quarterly and annual servicing is to be completed in accordance with the Bronto Operators Manual. These services will be completed in conjunction with your approved service provider.

No person shall carry out work on the Bronto aerial ladder or associated components unless they are deemed competent by the Australasian Bronto representative; contact the Fire and Emergency National Fleet Manager for guidance.

Section 3: Pump operation

Safety alerts

When operating the aerial with the vehicle jacked, use the off side collector head inlets first in order to reduce clutter or congestion on the pump platform.

When using this equipment, always use Class 2 hearing protection.

Pump technical information

Manufacture and type

W.S. Darley & Co.

Capacities and technical information

Main pump:

- Model - PSP.
- Rated output 450L/m @ 1050kPa.
- The main pump is conventionally driven by a shaft from the automatic transmission PTO.

High-pressure pump:

- Auto pressure Model H100-H.
- Rated output 300L/m @ 2500kPa
- The high-pressure pump is driven by a Darley Hydraulic Auto-Pressure System.
- This pump can be operated completely independently of the main pump.

Darley auto-pressure system:

- Automatically maintains preset output pressure of HP pump despite variations in:
 - intake pressure
 - output flow
 - engine RPM.
- A combination of HP & LP pressures is available simultaneously.
- Manual operation if automatic operation fails.

Foam Pro system

The Foam Pro System provides preselected mixing of Class A Foam concentrate from a 60L tank. This is ideally suited for use as a surfactant on both structure and vegetation fires involving Class A combustibles.

Overflows and relief valves

The overflow from the water tank is behind the rear wheels. The suction relief valves (one each side of the vehicle) are preset to 1200kPa. They are designed to protect the supply line into the pump as well as the suction side of the pump.

The suction relief valves are fitted between the collector head and the intake valve. In the event of high hydrant pressure, the relief valve opens and the excess water dumps to waste below the pump.

The high-pressure pump has a preset (kunkle) pressure relief valve, which has been set to 4200kPa. When this valve opens; the water goes to ground under the offside pump step.

Emergency stop

On the nearside pump panel (upper right section) is an emergency stop button. Pressing this button shuts down the engine. It can be reset by twisting in the direction of the arrows and lightly pulling out.

Pump panel overview

Control and instrument panels

The pump panels are engraved and colour coded to assist in component identification and relativity to each other.

The colour coding system is as follows:

Blue - main pressure

Green - pump suction/inlet

Pink - high pressure

Yellow - foam.

Note

- The maximum working pressure at which the system can inject foam is 2700kPa.
- Use Class A foam only.



Main pump operation

Pump engagement

The main pump is driven by the vehicle's transmission through a PTO.

To engage the main and HP pump:

1. stop the vehicle
2. apply the park brake
3. shift the transmission into neutral
4. turn on both pump PTO switches
5. check the 'engaged lights' come on
6. go to the pump panel.

Note

- PTO switches can be engaged in any order.
- Always engage **both** PTO's. The HP Pump will stay in neutral until activated using the Darley Auto-Pressure System at the pump panel.
- The engine revs must be below 900rpm before the PTO will engage.
- Keep the transmission in neutral throughout this procedure.

Operating the main pump

Employ conventional pump operation procedures.

Electronic throttle control

The connection from the throttle control to the engine is electronic not mechanical.

The control is speed sensitive.

- If the knob is turned slowly, revs increase slowly.
- If the knob is turned quickly, revs increase quickly.

The button in the centre of the knob returns the engine to idle when pushed.

Tank to pump switch

The tank to pump valve on this appliance is operated electronically. The valve may take up to 12 seconds to move from open to closed or vice versa.

Aerial waterway switch

The aerial waterway valve on this appliance is operated electronically. The valve takes 12 seconds to move from open to closed or vice versa.

High-pressure pump (HP) operation

Darley auto-pressure system

The Darley Auto-Pressure System automatically maintains a preset output pressure from the HP Pump despite variations in:

- intake pressure
- output flow
- engine RPM.

Note

The operator should anticipate this delay when operating the switch. There will be a delay of 12 seconds before the full pressure is delivered to the monitor.

Note

The operator should anticipate this delay especially when working from the tank and switching to hydrant supply. There will be a delay of several seconds before the full pressure shows on the compound gauge.



Darley Auto pressure (Source: Darley, 2005)

Setting the pump pre-set level

Once this level has been set the unit will always deliver water at this pressure. It will need to be changed if a different pressure is required.

To do this, complete the following steps.

1. Press the IDLE button.
2. Press the PRESET button & hold. The Setting Display (at top) will flash with current pressure setting.
3. Use INCREASE or DECREASE buttons to change setting.
4. When desired pressure setting is displayed, release PRESET button.
5. Typical setting for the HP pump 2500kPa.

“Out of water” programme

If the water tank is emptied, or if incoming supply is inadequate, the controller will increase pump RPM for up to 7 seconds.

If HP pump drops below 700kPa for 10 seconds, unit will reset to IDLE.

If this happens, re-establish water supply and give new instructions to the controller.

Emergency operation HP controller failure

If the Auto-Pressure System fails, it can be overridden using the Auto-Pressure Override Switch. This is a covered switch located behind the engine controls on the pump panel. Once this switch is activated the HP delivery will operate as a conventional pump with pressure controlled by the engine throttle.

Note

In this mode there is no automatic control of the HP delivery pressure. The pump operator must monitor and control this manually.

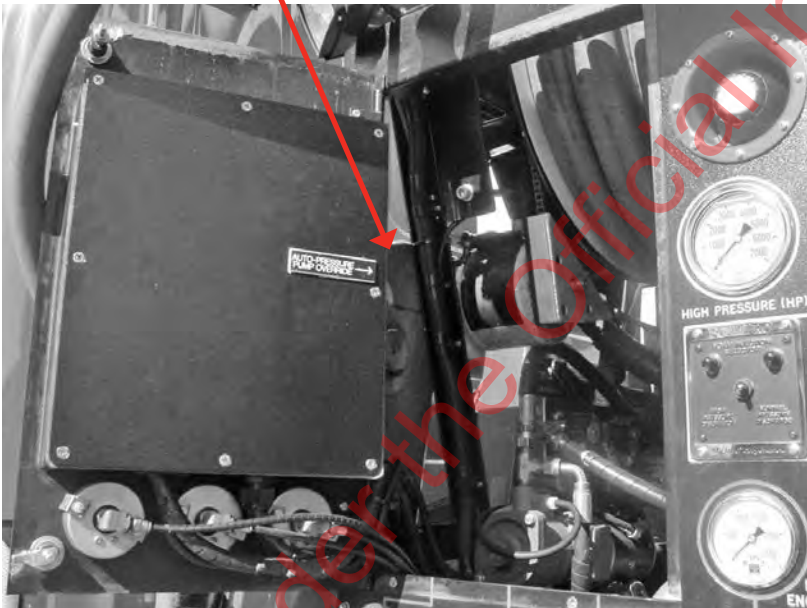

Controller override switch

Operating the HP pump

To operate the HP pump:

- Ensure water supply to main pump from tank or feeder.
- Increase throttle to attain approximately 700kPa from main pump.
- Press 'Preset' button on HP Auto-Pressure control.
- Adjust pressure if required with Increase/Decrease buttons.
- Adjust throttle (remember 700kPa must be attained within 10 seconds or system returns to idle).

Stand alone operation

To operate the HP pump:

1. Turn on the aerial/HP PTO switch in the cab.
2. Open tank to pump valve.
3. Open hose reel valves.
4. Adjust throttle (remember 700kPa must be attained within 10 seconds or system returns to idle).

FoamPro system

The FoamPro system is an electric motor-driven, flow-based proportioning system that measures water flow and then injects a proportional amount of foam concentrate to maintain the preset percentage.

The basic FoamPro system is shown below. The system will accurately deliver from 0.1% to 3.0% foam concentrate to the foam injector fitting.

The flow meter measures the water flow and sends a signal to the Control Module. Another sensing device monitors the foam pump output. Constant comparison of these two signals by the computer ensures correct foam concentration at all times independent of any variations in fire pump intake or discharge pressures. As water flow increases or decreases, the rate of foam concentrate injection is increased or decreased automatically to compensate.

Foam concentrate is injected directly into the water stream on the discharge side of the water pump. It is then fed as foam solution by the main fire pump into a standard fog nozzle, an air aspirated nozzle, or CAFS equipment.

Since foam is injected on the discharge side of the fire pump and check valves are installed, contamination of the water tank, fire pump and relief valve with foam concentrate is eliminated.

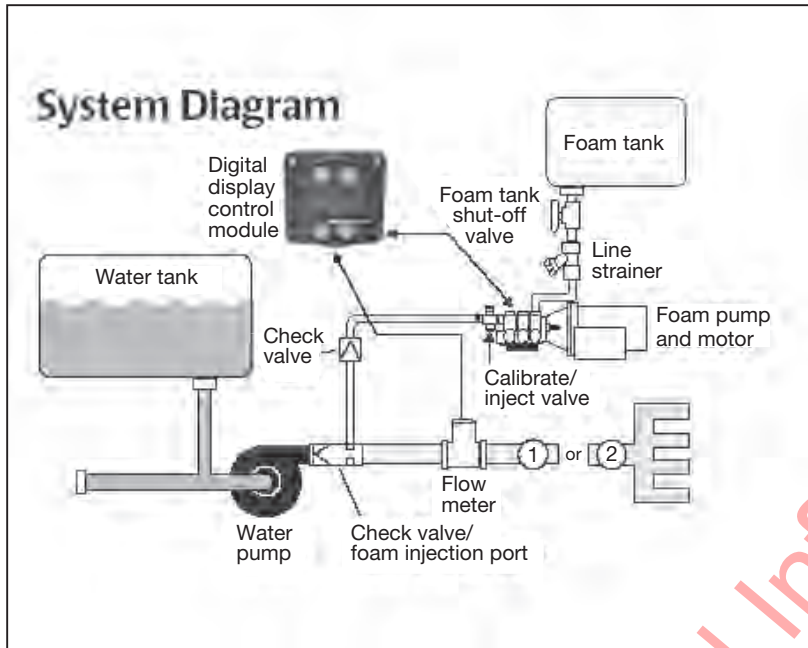

FoamPro system layout

Filling the tank

The foam tank is filled via an onboard foam refill pump. To fill:

1. Connect the foam pickup tube (supplied) to the camlock fitting on the pump panel.
2. Place the other end into the foam container.
3. Press the button in until foam starts to flow then release the button. The refill pump will automatically switch off when either the foam tank is full or the foam container is empty.
4. Remove the foam pickup tube and replace the camlock cap.
5. Flush the pickup tube and wash down any spilt foam.

Link

Further information regarding Class 'A' Foam can be found on The Portal.

Foam Pro operation

The Frumpier MultiFlo System is designed to monitor up to four paddlewheel flow meters and display the individual flow rates at the foam discharge outlets.

The FoamPro System displays the total flow value on the digital control module display. For example, if Flow A is 920L/m and Flow B is 1380L/m, the Display will read 2300L/m.

Buttons are provided on the FoamPro MultiFlo control module to allow the operator to read individual discharge flow rates. By pressing a button, the flow for that particular discharge outlet will be shown on the FoamPro MultiFlo control module display. The rate shown is the amount of water or foam solution flowing through the flow meter being monitored.

After calibration has been accomplished the system is fully automatic and needs no further adjustments. The FoamPro MultiFlo Control Module and FoamPro Digital Display Control Module are shown below.

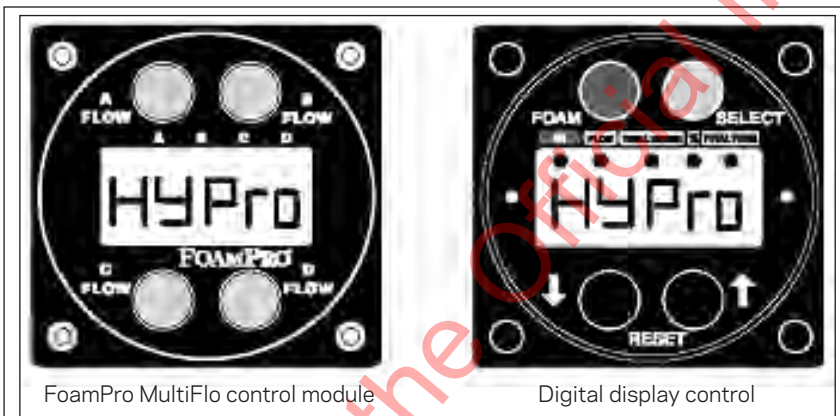

4 Series

P Series

At the pump panel:

At the pump panel:

1. Select the appropriate discharge setting on foam injection selector.
 - Select 'Normal Pressure Discharge' for:
 - monitor
 - 70mm outlets (near side only).
 - Select 'High Pressure Discharge' for hose reels and water dragon.
2. Select required outlet using the Flow Selector. Appropriate HP or LP Injector must also have been selected.

A = monitor

B = nearside 70mm outlets

C = hose reels and water dragon outlet.
3. Select Induction Rate using the Foam Proportioner.
 - Press Select until indicator is at '%'
 - Select the desired induction rate.
For example, the monitor is delivering 3780l/m @ 0.3% foam solution. The foam tank of 60L capacity will last for approximately 6 minutes
4. Press the foam button to commence injection.

When finished with foam flush the system with water until water is clear.

- If foam has been used in one hose reel both hose reels must be flushed.
- Exercise valves during flushing this removes and prevents sticking valves.

 **Note**

Foam solution will discharge out of water dragon outlet and can be used in conjunction with forestry deliveries.

 **Alert**

Ensure HP controller default setting Preset is adjusted to a safe operating pressure for the hose used.

 **Note**

Discharge foam only in approved location. Light flashes intermittently to indicate foam is injecting.

Section 4: Aerial operation

Safety

The following safety points must always be observed.

- When reversing, always have a guide at the rear of the appliance.
- When operating the jacking system, ensure all persons are clear of the appliance.
- Do not allow anyone to touch a working aerial, when working near electrical lines.
- Ensure no firefighter climbs on or off the ladder without the verbal permission of the operator at base controls.
- Be aware of overhead hazards when walking under the boom.
- Whenever the aerial hydraulics are activated, an operator must be at the control station.
- Helmets must be worn when aerial operations are being carried out.
- Never attempt to stop a leaking hydraulic line with your hand as high pressure fluid can penetrate the skin.

Alert

Hydraulic systems operate using extremely high internal line pressures. If a hydraulic line or component ruptures, do not attempt to stop or cover the leak with your hand. High pressure fluid can penetrate the skin.

Technical information

Manufacture type

Bronto F17 CTL – Allrounder

Outriggers

Maximum outrigger width jacks only.....	~ 3.3m
Maximum outrigger width with plates.....	~ 3.5m
Maximum outrigger force	~ 125kN
Maximum footplate pressure.....	~ 7.9kg/cm ²
Maximum footplate pressure with plywood ground plate.....	~ 5.1kg/cm ² (50x500x500)
Maximum operating ground slope for levelling of outrigger.....	7°

Aerial hydraulic system

Main pump output.....	~ 60L/min
Battery pump output	~ 10L/min

Main pressure.....	180 bar
Emergency operation pressure.....	160 bar
Adjustment of cylinder load control valves.....	345 bar
Reservoir capacity.....	~ 80L
Total system capacity.....	~ 167L
Hydraulic oil maximum operating temperature.....	80°C

General

Operating temperature range.....	- 25° -+ 40° C
Noise level	<85dB
Maximum wind speed.....	45km/hr

Aerial communication system

There are a variety of communication systems for the Type 4, ranging from individual purpose-built systems, to portable radios and headsets.

Levelling the appliance

Introduction to the levelling system

This appliance is equipped with an automatic levelling system that will function on slopes less than 3 degrees. On steeper gradients, it can be levelled manually first then switched to automatic, or levelling can be finished under manual control only.

General notes and warnings

- When positioning the vehicle on a slope, the cab must always be facing downwards.
- Ideally, the working object will be to the rear or side of it – this will provide best elevation and reach.
- Make sure no obstacles are above the boom.
- Ensure the front axle brake is applied. The switch is located in the rear aerial control locker.
- Before using the automatic levelling be sure there is enough room to extend all outriggers and the ground is hard enough to withstand outrigger footplate pressure.
- When you use the automatic levelling, be sure that there are no people around the working area of the outriggers.
- The automatic levelling moves the hand controls levers of the hydraulic valves of the outriggers automatically.

Keep hands out from the control levers and take care that the control levers can move freely.

- When you use the automatic levelling, you must be aware of what is happening around the appliance and be prepared to stop the process immediately.
- The jacks of the outriggers move automatically without warning when you use the automatic levelling. Keep clear of the outriggers during this process.
- If the auto levelling does not auto level on the slope, the operator may need to manually level the appliance using the level bubble as an indicator.
- Tyres must be off the ground at the completion of levelling.

Alert

The automatic levelling has the potential to cause injury.

Alert

Failure to ensure all tyres are off the ground at the completion of levelling can create an unstable situation. This is because the Scania airbag system can sense less weight and automatically increase pressure, resulting in weight being taken off the jack/s.

Components of the levelling system



4 Series



P Series

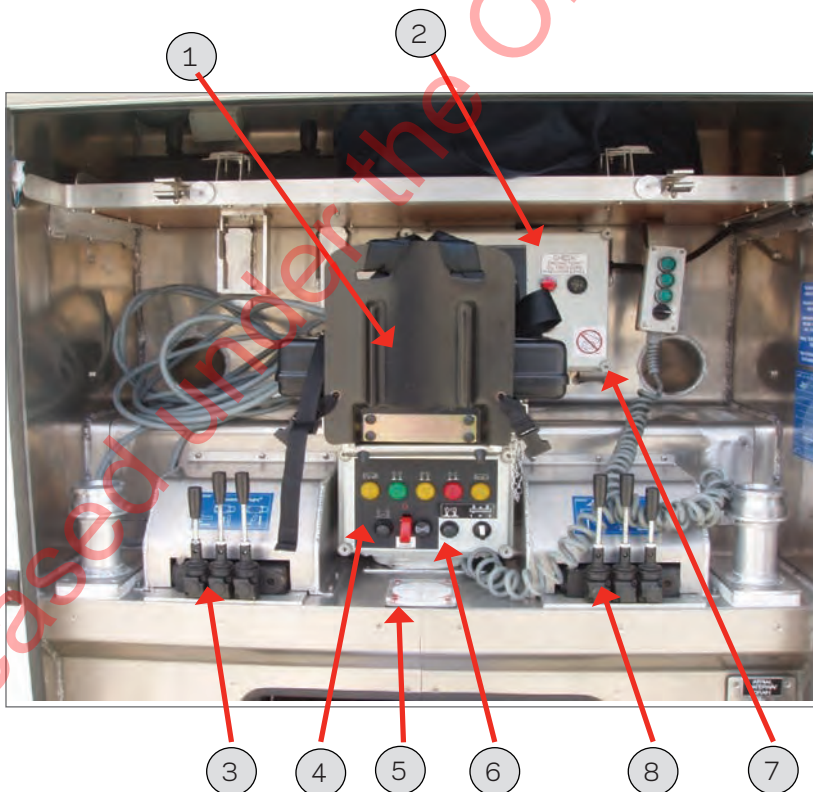

Location of components of the levelling system

Components	
1	Remote control station in transport position
2	Instrument panel
3	<p>Left side manual jacking controls:</p> <ul style="list-style-type: none"> ▪ Outer lever - left rear outrigger out horizontal and return to transport position ▪ Centre lever - left rear jacks extend and retract ▪ Inner lever - left front jacks extend and retract
4	<p>Central device, which houses both the computer and inclinometers along with a number of relays:</p> <ul style="list-style-type: none"> ▪ Computer - microprocessor based calculator and control unit ▪ Two inclinometers for measuring the angle of the chassis ▪ Mechanical limit switches for the ground pressure of the outriggers <p>Electro-hydraulic valves and two proportional valves for the control of the outriggers</p>
5	Level bubble for use when manually levelling the appliance
6	Front axle brake switch, fitted with safety cover (red)
7	Remote control device for the auto levelling system - this device is linked to the central device by an umbilical cord and operates the outriggers and jacks
8	<p>Right side manual controls jacking:</p> <ul style="list-style-type: none"> ▪ Outer lever - right rear outrigger out horizontal and return to transport position ▪ Centre lever - right rear jacks extend and retract ▪ Inner lever - right front jacks extend and retract

Remote control device

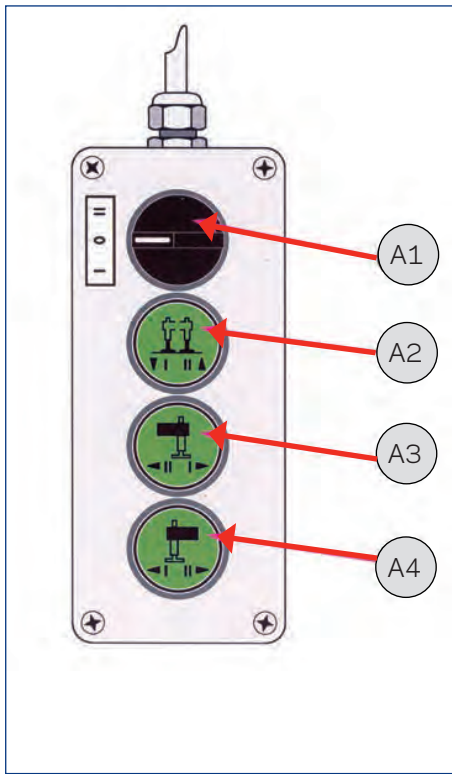

(Source: Bronto Skylift, 2003)

A1	<p>Selector switch</p> <p>I = Jacks and outriggers to operating position</p> <p>O = The remote control device is OFF</p> <p>II = Jacks and outriggers to transport position</p>
A2	<p>Vertical jacks up or down depending on position of selector switch A1</p> <p>Activates automatic levelling when selector switch is in position I</p>
A3	<p>Right rear outrigger beam in or out depending on position of selector switch A1</p>
A4	<p>Left rear outrigger beam in or out depending on position of selector switch A1</p>

Central device (4 Series)

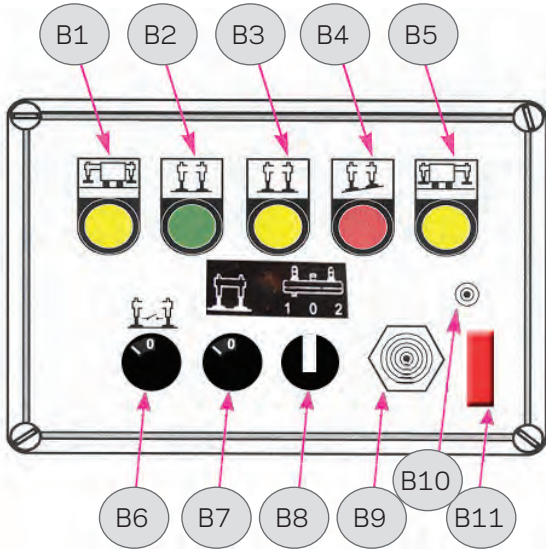

Central device (P Series)

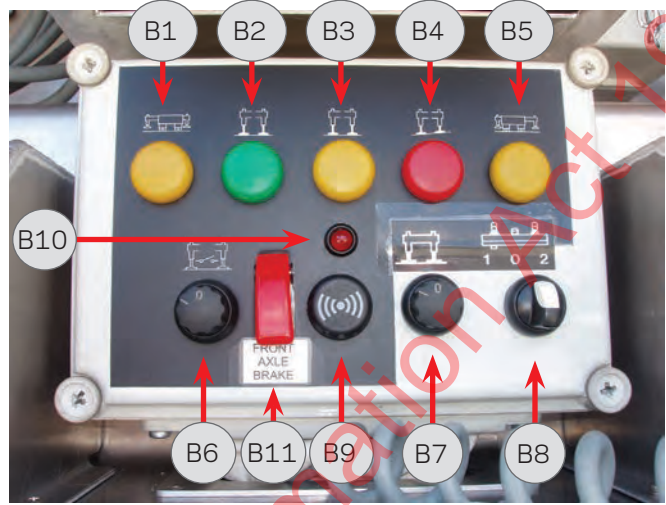

Source: Bronto Skylift, 2003

Switches on the central device

- B1 Left rear outrigger completely extended
- B2 Auto levelling light - levelling is okay (on completion of auto levelling cycle only)
- B3 Outrigger ground plate contact okay
- B4 Ground slope over 3° (activates on auto levelling only)
- B5 Right rear outrigger completely extended

Switches on the central device

- B6 Main power switch (all operations):
 0 = Off: automatic levelling system is off
 I = On: automatic levelling system is on
- B7 RPM switch
 Position 0 = Off: outrigger is disabled, boom movement possible
 Position 1 = On: outrigger is enabled, RPM increases, boom movement disabled
- B8 Control station selector switch
 Position 0 = boom control de-energised
 Position 1 = control station 1
 Position 2 = control station 2
- B9 Warning buzzer
- B10 Front axle warning light
- B11 Front axle brake switch

Levelling procedure

Activate system for both automatic and manual operation in cab

1. Position appliance (refer to Section 2 - Siting the Appliance for details).
2. Gearshift to neutral
3. Engage parking brake.
4. Engage Aerial ladder/high-pressure pump PTO switch.

Extending the outriggers

1. Apply front axle brakes by switching the front axle brake switch from its safety off position to the on position (located in rear control locker).
2. Switch ON the main power switch (B6).
3. Turn on RPM switch on (B7).
4. Turn selector switch (A1) of the remote control device to position I (Levelling).
5. Extend the outriggers by pushing buttons A3 and/or A4 of the remote control device. It is permitted to move both outriggers at the same time.
6. The outrigger signal lights (B1 and B5) of the central device illuminate when left/right outrigger beams are completely out.
7. Place outrigger plywood ground plates under jacks, if required.

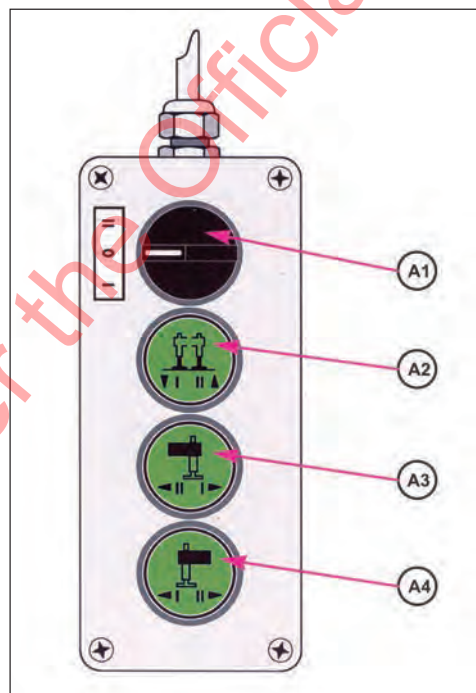

(Source: Bronto Skylift, 2003)

Note

If the engine stops when engaging the Aerial ladder/high-pressure pump PTO switch (in the cab), check the emergency stop pushbutton on the control station.

Automatic levelling

1. To start the automatic levelling, push and hold button (A2) of the remote control device.
2. Continue to push button (A2) until the jacks are in the operational position and levelling is OK. Once automatic levelling stops pause and wait for the green signal light (B2), then release button.
3. Repeat automatic levelling cycle until all tyres are off the ground.
4. The Appliance is level when the green signal light (B2) is illuminated.
5. If all the tyres of the appliance are off the ground and the levelling is OK, turn off main power switch (B6) and RPM switch (B7). The aerial ladder is ready for operation.
6. Check level bubble.

Notes:

If the inclination of the ground is more than three degrees the buzzer beeps and level warning light (B4) illuminates. This requires the appliance to be levelled manually first.

All wheels must be clear of the ground. Sufficient pressure has to be detected by the onboard computer across all four jacks or all aerial movements will stop and warning light (B3) illuminates. If this happens operate booms back to transport position and check levelling

The buzzer also beeps and red level light comes on, if the auto levelling fails or is interrupted. Re-adjust with either auto levelling or manual controls.

If the levelling frequently fails, contact your service agent.

Note

Automatic Levelling will stop immediately, if you release the push-button. The emergency stop button on the control station device will also stop automatic levelling immediately.

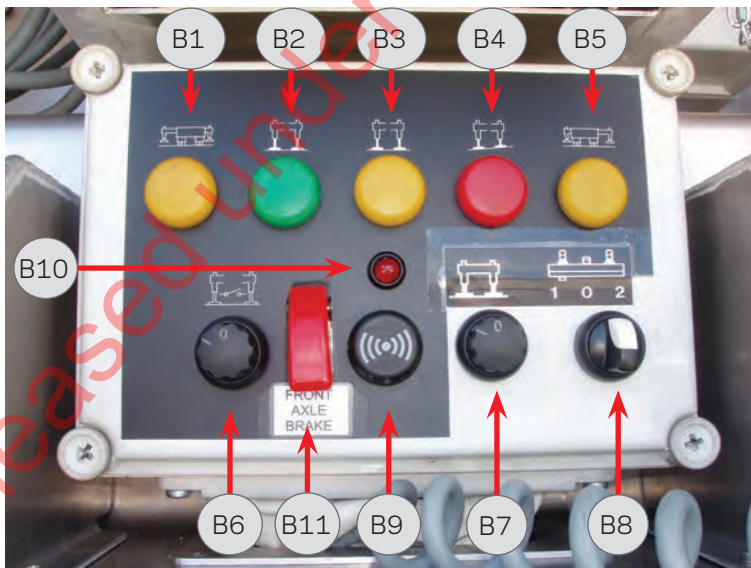

(Source: Bronto Skylift, 2003)

Note

Some lights and switch position may vary with different appliances.

The cruise control switch in the cab needs to be in the "ON" position for operations. If the auto revs fail to ramp up, check this switch position (P Series only).

Manual levelling procedure

Extending the outriggers

This can be done two ways.

- Use the automatic levelling remote control.
- Use the manual levers in the rear locker.

Manual levelling

1. Place outrigger plywood ground plates under jacks, if required.
2. Level or near ground, use the manual controls in the rear of the appliance to lower all 4 jacks until they contact the ground. Once jacks are in contact operate levers in pairs only i.e. left side, right side, front or back.
3. Raise the low side of the appliance until it is level crosswise.

Note: If the ground slope is over 2 degrees, carry out Step 3. Then operate opposite jacks to contact the ground ensuring the bubble is centre. Then carry out Step 4 as below:

4. Raise the front of the appliance until it level lengthwise.
5. Continue to raise the appliance until all tyres are off the ground and it is levelled within + or - 0.5 degrees. Check level bubble.
6. Turn RPM-switch (B4) off (position O).
7. Ensure ground pressure indicator light (B3) is off indicating sufficient ground pressure.

Note

Green light will only illuminate on completion of the automatic levelling cycle and will not illuminate with manual jacking.

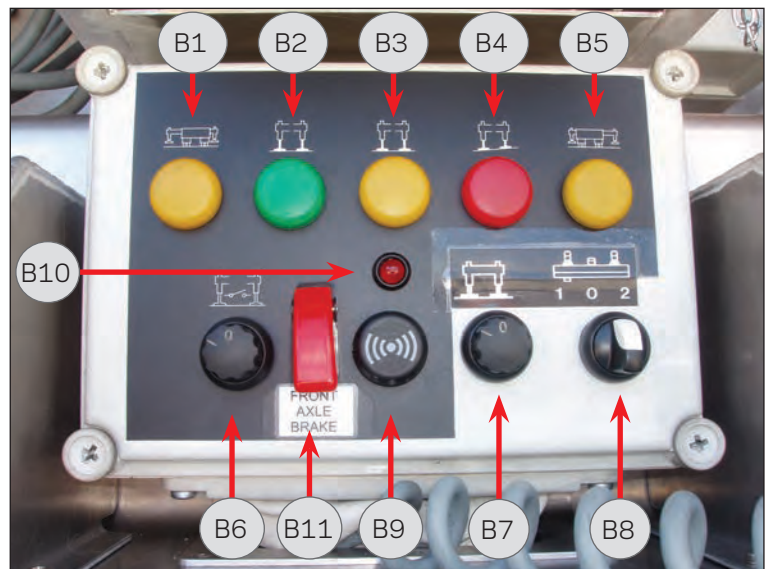
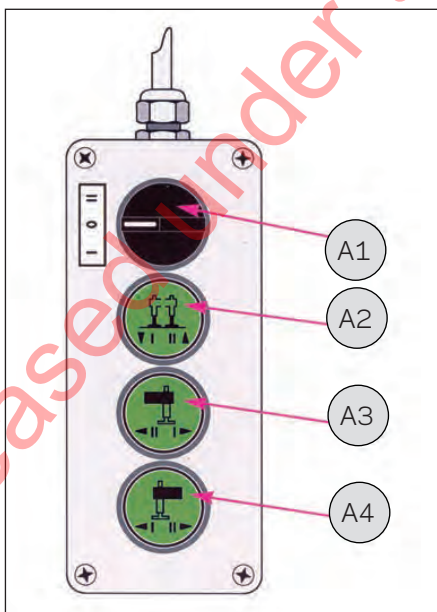

Remote control and central device (Source: Bronto Skylift, 2003)

Lowering the appliance

Automatic lowering sequence

1. Turn on automatic levelling power switch.
2. Turn the RPM-switch.
3. Turn selector switch of the remote control device to position II.
4. Push button A2 and keep it pushed until all jacks are lifted fully up.
5. Push the buttons A3 and A4 until all outriggers are fully retracted.
6. Turn selector switch of the outrigger remote control device to position O.
7. Turn main power switch and RPM switch off.
8. Release front axle brake.
9. Stow outrigger ground plates.
10. Check all locker doors are closed.
11. Disengage aerial ladder/high-pressure pump hydraulic "PTO" switch.
12. Check Bronto cab warning lights are not illuminating.

Manual lowering sequence

1. Turn RPM-switch (B7) on (position I).
2. Lower appliance evenly until wheels contact ground.
3. Raise all jacks simultaneously.
4. Retract outriggers.
5. Turn RPM-switch off (position O).
6. Release front axle brake.
7. Stow outrigger ground plates.
8. Check all locker doors are closed.
9. Disengage aerial ladder/high-pressure pump hydraulic "PTO" switch.
10. Check Bronto cab warning lights are not illuminating.

Use of ground plates

Ground conditions

- If the stability of the ground is in doubt use ground plates under the footplates.
- Consideration must be given to the risks associated with placing jacks near or on:
 - manhole covers
 - soft ground

Alert

Do not use manual levers to retract outriggers whilst jacks are in contact with the ground. Doing so will damage the outriggers and/or jacks.

Note

The increased area of the ground plate displaces the weight over a larger surface area. Ground plates also compensate for uneven ground.

- drains, pipes, underground tanks
- freshly dug roading
- cracks and joins
- concrete curbing and footpaths.

Use of ground plates

Ground plates must be used in all instances when jacking the Type 4 Appliance.

If required a maximum of four outrigger ground plates can be fitted under one outrigger to compensate for uneven ground.

Maximum footplate pressure7.9kg/cm²

Maximum footplate pressure with ground plates.....5.1kg/cm² (50x500x500).

If ground plates need to be stacked use the method shown below.

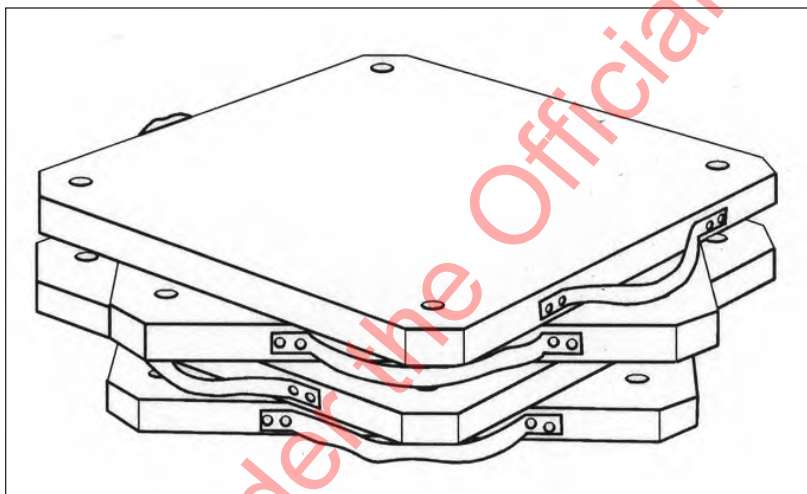

Correct method of stacking ground plates (Source: Bronto Skylift 2003)

Alert

When levelling the appliance, make sure:

- the contact between the ground, ground-plates, and footplates is sufficient
- footplates will not slide on the ground-plates, and the ground-plates will not slide on the ground.

(Ice, sand, dirt, and mud etc. reduce the friction between ground and the ground-plate).

Remember it is the responsibility of the operator to ensure safe levelling of the appliance.

Alert

Allowance is needed for the foot plate of the front jack to slide out when the appliance is raised off the ground.

To minimise the need to reposition ground plates you must align the top plate so it is square with the appliance.

Released under the Official Information Act 1982

Boom operation

Introduction

All movements of the boom can be controlled simultaneously or one by one from the control station. When one of the control levers is moved and the RPM-switch on the end of the lever is pressed, the pressure of the hydraulic system will automatically rise to the preset working level.



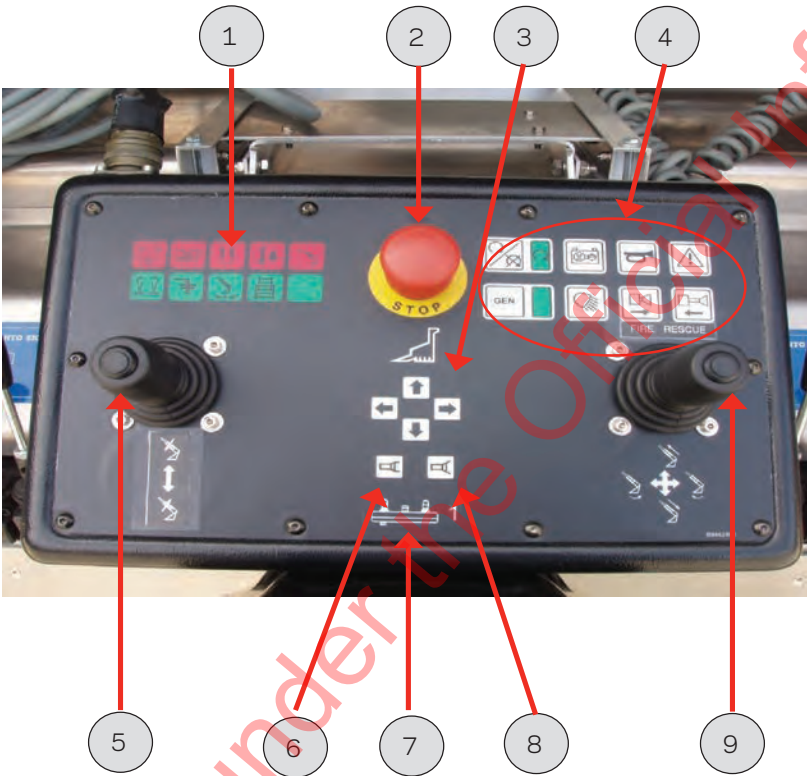

Control station components

Note
Some control stations may have a communication ON/OFF switch and PPT.



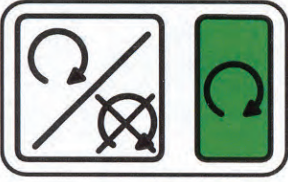

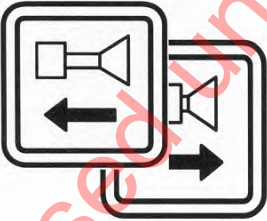

1	Warning and signal lights
2	<p>Emergency stop button:</p> <ul style="list-style-type: none"> ▪ When this button is pushed and the main circuit is on, the hydraulic pressure is automatically switched off and the appliance engine is stopped. ▪ It must be manually reset by pulling knob up. <p>Note: If the engine stops when engaging the Aerial ladder/high-pressure pump PTO switch (in the cab), check the emergency stop pushbutton on the control station.</p>
3	Monitor movements: up, down, left and right
4	Control Station buttons
5	<p>Control lever for raising and lowering boom (ladder)</p> <ul style="list-style-type: none"> ▪ RPM button is located on top of the lever and has to be pushed to activate the movement. ▪ The movements are ramped to prevent jolting sudden stops. They continue slightly after releasing the controls.
6	Monitor nozzle adjustment, stream
7	Control Station ID No:
8	<p>The control station can be connected to the plugs at either the outrigger control station, the turntable, or at the pump panel. Each control station is labelled either 1 or 2. This number indicates which control station is in use. When the stations are unplugged/plugged it is important that:</p> <ul style="list-style-type: none"> ▪ the unit is powered off (disengage aerial ladder/high-pressure hydraulic PTO switch in cab) ▪ the blind plugs are attached to the unused plugs.
9	<p>Control lever for telescopic and rotation movements:</p> <ul style="list-style-type: none"> ▪ RPM button is located on top of the lever and has to be pushed to activate the movement. ▪ The movements are ramped to prevent jolting sudden stops. They continue slightly after releasing the controls.

Control station buttons

	<p>Start/Stop button and status light for operating engine.</p>
	<p>Signal horn.</p>
	<p>Safety limit override button.</p> <ul style="list-style-type: none"> By-pass button for the cab collision protection. By pushing this button the system overrides safety stops and all movements are possible.
	<p>Working lights switch.</p>
	<p>Button for battery-powered pump.</p> <p>The battery-powered pump is fitted to provide rotation and boom movements if the main engine fails. It is to be used in emergency situations only.</p> <p>Note: Use the battery-powered pump sparingly at operating cycles of "8 minutes on, 5 minutes off". Excessive use may overheat the pump motor.</p>
	<p>Button for extension and retraction of the monitor telescopic waterpipe extension.</p>

Control station warning and signal lights

	<p>Emergency stop (red).</p> <p>Signal light illuminates when the emergency stop button is activated (down).</p>
	<p>Telescope chains (red).</p> <ul style="list-style-type: none"> ▪ Blinks if the chains are loose. If the limit switch for the chains is activated for more than 2 seconds the emergency stop cycle is activated and an acoustic signal sounds. <p>Note: When this warning light goes on and still stays on, operation of the unit must be stopped immediately and contact your Bronto Skylift service provider.</p>
	<p>Fault alarm (red).</p> <ul style="list-style-type: none"> ▪ This illuminates and the emergency stop light blinks if: <ul style="list-style-type: none"> ▫ the emergency stop button has been pushed ▫ the control stations or blind plugs are not correctly plugged in ▫ the Safety Limit Override button has been activated (see previous page). ▪ If it illuminates and the signal light of a defective element blinks: <ul style="list-style-type: none"> ▫ stop the operation of the unit immediately and contact the Bronto Skylift service provider. ▪ If it blinks, a major system defect in the control system has been detected: <ul style="list-style-type: none"> ▫ stop the operation immediately and contact the Bronto Skylift service provider.
	<p>Ground pressure indicator (green).</p> <p>Illuminates when the ground pressure of all outriggers is reached.</p> <p>It turns off if the ground pressure is too low. Operate booms back to transport position and check the levelling.</p>

	<p>Turntable housing alignment (green).</p> <ul style="list-style-type: none"> ▪ Illuminates when the booms are in the left or right side sector or over the back sector (transport position). ▪ Turns off in the front sector (cab collision protection). ▪ To turn the booms in the transport position, turn the turntable until the booms are close to the middle and the green light turns off, then continue in the same direction until the light goes on again. ▪ If the movement stops close to the transport position, the cab collision protection is activated - this happens when the booms are in to low a position, because the same limit switch is used for the cab protection and the middle line recognition. To prevent this, rotate the turntable with the booms high enough over the middle line and then lower the booms.
	<p>Ladder alignment signal light (green).</p> <ul style="list-style-type: none"> ▪ Illuminates when the ladder rounds are in line.

Auxiliary controls

The Auxiliary Controls are located at the base of the turntable

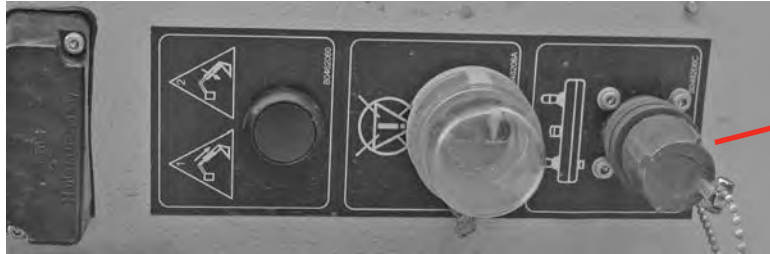

(Source: Bronto Skylift, 2003)

Components

<p>1</p>	<p>Emergency lowering button ('leakdown' button) for telescope and boom, located at the turntable. When pressed, the following sequence is carried out.</p> <ol style="list-style-type: none"> 1. The telescope is retracted to its minimum position. 2. The boom is lowered to its minimum position.
<p>2</p>	<p>By-pass for emergency stop cycle, located at the turntable. Do not use (service provider only):</p> <ul style="list-style-type: none"> ▪ the emergency stop button has been pushed and cannot be restored by the user <ul style="list-style-type: none"> ◦ Note: Rehouse booms to transport position and contact the Bronto Skylift service provider. ▪ the button is protected by a transparent plastic cover and sealed to prevent improper use.
<p>3</p>	<p>Control Station Plug (not used for normal operation) When the stations are unplugged / plugged it is important that:</p> <ul style="list-style-type: none"> ▪ the unit is powered off (disengage aerial ladder/high-pressure hydraulic PTO switch in cab) ▪ the blind plugs are attached to the unused plugs. <p>The two other plugs for the control stations are located at the outrigger control station and at the pump panel. The control stations can be plugged to any of the plugs. The number at the lower side of the control station indicates the control station number. Note: Not used for normal operation</p>

Boom operating procedures

Boom movement is controlled by the levers on the control station. The RPM switch on the top of the lever must be pressed before the lever is moved or no movement will occur.

(Pressing the RPM switch raises engine RPM and hydraulic pressure to a preset level.)

When the pump is operating in conjunction with the aerial, RPM is controlled at the pump station. Pump revs can be operated higher than preset levels for the aerial, which will cause boom functions to operate quicker. The RPM switches on the control levers must still be pressed for movement to occur.

All boom movements can be activated either simultaneously or one by one using the levers.

Elevating booms

When elevating or lowering the booms, follow this order.

1. Always elevate the boom from its support first so that either extending or rotation becomes possible.
2. Extend the monitor to operating position before use.

Lowering booms

1. Check aerial waterway drain valve is open.
2. Check and house monitor
3. Retract telescopic sections of the boom.
4. Train the turntable into the transport position.
 - Rotate boom until indicators arrows are aligned and turntable rotation indicator light is illuminated.
 - If the movements stop close to the transport position, the cab collision protection may have activated. To prevent this, turn the turntable with the booms high enough over the middle line and lower the booms.
5. Depress the boom onto its transport support.

Note

- All movements which could cause the boom to come out of its permitted working range are prevented during normal operation.
- The RPM buttons are located on top of the levers and must be pushed to activate the movement.
- The movements are ramped, so that they continue slightly after releasing the handle or the RPM button.

Alert

Remember, boom function shall not be energised without the acknowledgement of the operator at the head of the ladder.

Emergency and manual lowering

Emergency lowering

Two emergency systems have been fitted to the appliance for use by the operator to effect the lowering and rotation of the aerial ladder if the main system fails, attempt in the following order.

1. Attempt to use the battery powered hydraulic pump system (operator use).
2. Use the emergency lowering button to bleed down the aerial ladder (operator use).

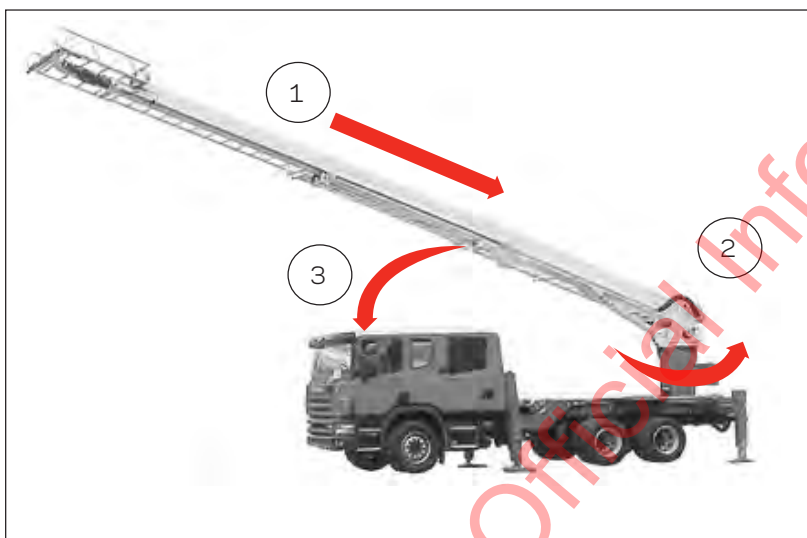

(Source: Bronto Skylift, 2003)

Emergency boom lowering sequence

Always carry out movements (see figure above) in the following order.

1. Retract telescopic boom.
2. Rotate to transport position.
3. Depress the boom gently onto the transport support.

Using the battery powered hydraulic pump

The battery-powered pump is fitted to provide rotation and boom movements if the main engine fails. It is to be used only in emergency situations.

If this process is unsuccessful contact your service provider or in an emergency, lower the ladder as described below.

Note

If these two methods fail, contact your service provider.

Alert

Make sure that there is NO PEOPLE and NO EQUIPMENT left on the ladder during emergency lowering.

Note

Use the battery powered pump sparingly at operating cycles of "8 minutes on and 5 minutes off". Excessive use may overheat the pump motor.

Emergency lowering button

If the Battery Powered Hydraulic Pump system fails the ladder can be safely lowered using the Emergency Lowering Button (see Instrument Panel on page 61). On operation of this button the telescopic boom will retract and the boom will lower. No rotation is possible using this method.

No further operation is now possible. Contact your service provider.

Aerial ladder

Technical information

Working range

Maximum working height.....	18m
Maximum side outreach at ladder head.....	14m
Rotation is continuous.....	360°
Maximum wind speed	45kph

 **Note**

Continuous rotation is not possible when an auxiliary power supply is connected to the boom.

Ladder load

The following maximum loading limits are to be observed. There is to be a maximum of:

- one person at the head when the aerial monitor is in use
- one person at the head while ladder is moving.

At other times there is to be a maximum of:

- four persons on the rescue ladder at any one time
- two people at a time on any one section
- two people at a time at the head.

Ladder rescue operations

It is mandatory to de-energise boom functions when people are climbing or unattached for any reason. Boom function should not be energised without the acknowledgement of the operator at the head of the ladder.

The Master Selector Switch must be in the '0' position to de-energise. This will isolate the boom controls.

When using the ladder in the rescue role a firefighter should be present at the base of the turntable to guide non-operational people off the ladder and down off the roof of the appliance to ensure their safety.

Note

The operator must not make any boom movements that cause dynamic forces when persons are on any section of the ladder.



Maximum loading of ladder
(Source: Bronto Skylift 2003)

Fall restraint

Restraining sling

Any firefighter working at the head of the ladder must use a full body fall arrest harness. Two sets of fall protection equipment are provided with each Type 4 Appliance.

- A maximum of two harnesses can be secured to the anchor point at the head of the ladder.
- Operators are reminded that to minimise excessive shock loading of the fall restraint equipment in the event of a fall, only the provided sling must be used to anchor to the anchorage point.

A 250mm restraint webbing sling fitted with two carabiners (see image below) is provided to enable anchorage to the anchor point at the head of the ladder.

This is the only restraint equipment used to anchor personnel at the head of the ladder.



Before using

Before using the restraint sling, check the general condition and stitching of the sling.

Using the restraint sling

- Fit the full restraint harness. Check the straps.
- Attach the restraint sling to the attachment point of the harness using the carabiner provided. Check that both front attachment loops of the harness are coupled by the carabiner.
- Ensure the screw-gate is correctly closed and locked.
- Attach the other end of the restraint sling to the anchorage point of the aerial ladder (see figure on following page) using the second carabiner.
- Ensure the screw-gate is correctly closed and locked.



Attachment point at the head of the ladder

Personal safety check

Before placing any load on the fall restraint equipment you should conduct a personal safety check, which is known as the ARCHER check.

- A Anchor and associated rigging thoroughly checked.
- R Restraint sling attached correctly.
- C Carabineers correctly aligned and the gate screwed shut.
- H Harness correctly fitted and adjusted.
- E Equipment check (helmet, gloves, boots, BA etc.).
- R Ready to commence.

Using breathing apparatus equipment

When using breathing apparatus with the fall restraint system observe the following:

- The fall restraint harness is to be worn underneath the breathing apparatus set.
- Communications between all parties is essential.
- Be aware of cylinder duration and limitations.
- Take extreme care when visibility is limited.
- Be aware of the change to the bodies centre of gravity while wearing BA.

Aerial monitor system

Manufacture and type

Akron Electric Gemini 3479 with TFT mastermatic Tip.

Remote electronic controls for Stream/Fog, Up/Down or Left/Right. Monitor can be operated remotely from the ground station or from the aerial ladder head.

Maximum Flow.....4500L/m
Maximum Pressure.....1600kPa

Monitor operation

Initial

Engage the main pump in accordance with the main pump operation manual.

General operating notes.

- Ensure the aerial drain lever is in the closed position (see waterway drain on the following page).
- When supplying water to the pump utilise off side collector head inlets first to reduce clutter around pump panel.
- Beware of water hammer.
- Monitor control is on/off only so it is not possible to open and close water valves slowly. Where possible, open the valve with the pump pressure low then slowly increase it.
- Under freezing conditions, do not extend the telescopic sections of the boom completely; this is to prevent compressing of possible ice build-ups between the telescopic sections.

Note

If using the monitor and ladder at full elevation it is recommended that the ladder be depressed approximately 0.5-1 metre to allow for possible 'jet reaction'.

Extend the telescopic extension ram

1. Extend the monitor to operating position. Once extended the 'Ram Extended' red warning light will be illuminated.
2. From this position, using either the controls on the control station or the monitor remote control, the monitor can be trained to any position within its operating range.

Stowing the monitor

1. Open all drains and elevate boom above horizontal to drain water from pipe work. Leave all drains open until the ladder is fully housed
2. Before stowing the booms, make sure that the monitor is in its transport position.
 - Rotate and align nozzle until both green alignment lights are illuminated.
 - Retract the monitor extension ram fully.



Aerial waterway drain

Appendix 1: Darley PSP and auto-presssure

Darley PSP & Auto Pressure



Fire Pump System for N.Z. Fire Service



Operations Manual **W.S. Darley & Co.**

PSP & Auto-Pressure
Operations Manual DRAFT

Darley PSP & Auto Pressure Pump Configuration



- Two separate Pumps -
 - Main Pump, Model PSP
 - rated 4500 l/min @ 1050 Kpa
 - High Pressure Pump, Model H100-H
 - rated 300 l/min @ 2,500 kPa
- Main pump – conventional drive by shaft from PTO on top of auto-transmission.
- HP Pump driven by Darley patented electronic-hydraulic **Auto-Pressure** system.



Darley Auto Pressure

- Automatically Maintains Preset Output Pressure of HP Pump despite variations in:-
 - Intake Pressure
 - Output Flow
 - Engine RPM
- Safety & Simplicity of Operation -
 - A combination of HP & LP pressures is available simultaneously.
- Reduces the workload of Pump Operator.
- Manual operation if automatic fails

PSP & Auto-Pressure
Operations Manual DRAFT



Auto-Pressure System

Hydraulic Drive

- **Power Take-Off (PTO) unit on truck transmission - Engaged in cab.**
- **A variable displacement hydraulic pump is driven by PTO.**
- **Hydraulic pump drives a hydraulic motor which drives the HP Fire Pump.**
- **An electronic controller adjusts hydraulic pump to maintain Preset H.P. Pump output pressure.**



PSP Main Pump

- Shaft from PTO drives direct to pump gearbox.
- PSP is a single stage high capacity pump.
- Pump is conventionally midship mounted.



Auto-Pressure System

High Pressure Pump

- Hydraulic Motor drives H.P. pump.
- Water intake from either tank or Main Pump. (1 or 2 stage operation.)
- Output to HP reels or Water Dragon
- Transducer reads pressure.



PSP & Auto-Pressure
Operations Manual DRAFT



Darley **Auto-Pressure** Pressure Transducer

- Pressure produced in High Pressure Pump is measured by electronic transducer.
- This signals pressure to the Controller.



PSP & Auto-Pressure
Operations Manual DRAFT

FRC

Electronic Throttle Control

- The PSP pump and *Auto-Pressure* system require adequate engine RPM to drive them.
- Rotate throttle clockwise to increase pressure.
- Push centre knob for Idle.
- Throttle is sensitive to speed of rotation.



PSP & Auto-Pressure
Operations Manual DRAFT

8

Darley **Auto-Pressure** HP Pump Control Head



- Upper Display = Required (Preset) Pressure
- Lower Display = Actual (Pump) Pressure
- *Preset* - Instructs Pump to go to preset pressure
- *Idle* - Instructs Pump to go to zero pressure.
- *Increase/Decrease* - Raise or lower pump pressure
- *OK to PUMP* = H.P. Pump PTO Engaged

Darley Auto-Pressure Control

- What it does:-
 - Receives Fire Pump pressure & RPM data.
 - Instructs variable flow control of hydraulic pump to adjust speed of hydraulic motor.
 - Has logic programme to detect loss of prime, & cavitation.
 - Maintains constant output pressure



PSP & Auto-Pressure
Operations Manual DRAFT



PSP and Auto-Pressure

Get -to Work, Cab actions

- **Park Brake On**
- **Transmission in neutral.**
- **Engage Both Pump PTO switches.**
- **Check “Engaged” Lights showing.**
- **Go to Pump Panel**



Auto-Pressure System

Setting Preset Level on Controller

- Press **IDLE** button
- Press **PRESET** button & hold. **SETTING** Display will flash current pressure setting.
- Use **INCREASE** or **DECREASE** buttons to change setting.
- When desired pressure setting is displayed, release **PRESET** button.
- Typical setting- **H.P. Pump 3500 Kpa**



PSP & Auto-Pressure
Operations Manual DRAFT

H.P. Hose Reels, Pump Panel Actions



Auto-Pressure System

- Open Tank-Pump Valve
- Open Hose Reel Valves
- Short Primer actuation.
- Increase Throttle to approx 700 kPa from Main Pump.
- Press **PRESET** button on HP Control.
 - Adjust HP Pressure if required.
(Use *Inc/Dec* buttons)
 - Adjust Throttle if required.
 - Note:- 700Kpa must be achieved in 10 sec. Or system returns to **IDLE**

H.P. Pump - Priming Procedure

Auto-Pressure System



- Pumps have mechanical seals and may be left full of water except in freezing conditions.
- If pump not primed, or water is lost,
 - Press *IDLE* buttons on throttle and Control.
 - Ensure *TANK-PUMP* valve is open.
 - Operate *PRIMER* Control until water is discharged from primer outlet.
 - Press *PRESET* button on Controller -
 - Set adequate Engine RPM
 - Pressures should rise and hold at preset level.

“Out of Water” Programme

Auto-Pressure System



- If Water Tank is emptied, or if incoming supply is inadequate, the controller will increase Pump RPM for up to 7 sec.
 - If HP Pump drops below 700 Kpa for 10 sec. unit will reset to IDLE
- Re establish water supply and give new instructions to controller.

PSP Main Pump, Pump Panel Operation



- Feeder Line to Collector Head - Open Suction Inlet Valve.
- Run Deliveries (or pre-connect lines) - open delivery valves.
- Adjust Throttle -Set adequate Engine RPM
 - Check Correct Pressure is achieved.
- Conventional Pump Operation.



PSP Main Pump, Priming Procedure

- **Connect Suction Hose to inlet.**
- **Open Suction Inlet Valve.**
 - Operate *PRIMER* Control until water is discharged from primer outlet.
 - Set adequate Engine RPM
 - Partially open discharge valve.
 - Release primer as pressure starts to rise.
 - Adjust pressure using *Throttle*.
- **Conventional Pump Operation.**

Water Dragon Set-Up

- **Connect 38mm HP hose (yellow) to inlet of Water Dragon**
- **For maximum flow, fit plain dividing breeching to outlet.**
- **Run twin 90mm hoses back to vehicle collector head**
- **Place in static water supply and ensure kinks removed from all hoses - monitor during operation.**



PSP & Auto-Pressure
Operations Manual DRAFT

18



Water Dragon Set-Up



- **Connect 38mm HP hose (yellow) from “Water Dragon” outlet**
- **Run twin 90mm hoses (Red) back to vehicle collector head**
- **Run 70mm deliveries to fire, (Select Nozzles for Max. total flow 1500 l/min)**
- **Ensure kinks removed from all hoses - monitor during operation.**

Water Dragon Operation



- Both Pump PTO in gear
- All Pump panel valves closed to start
- Open Tank-Pump Valve - Short Primer Operation
- Increase throttle, pressure shows on Main Pump, Press PRESET on Auto-Pressure HP control –
- Open Water Dragon outlet valve, Increase HP Pump pressure to 3,500 kPa.
- As water arrives in 90mm feeders, ease all kinks in hoses,
- Open Suction Intake Valve, allow tank to refill.

PSP & Auto-Pressure
Operations Manual DRAFT

20



Water Dragon Operation – (Cont.)

- When Tank is full – close Tank-Pump Valve
- Slowly open first discharge valve, - fill hose, then gate valve to required delivery pressure.
- Maintain 3,500 kPa on HP pump.
- IF pressure still shows on compound gauge, slowly open second discharge valve to fill and then supply second delivery.
- YOU MUST CONTROL OUTPUT FLOW so that positive pressure is retained on feeder lines. (Compound gauge, and thumb on feeder line)

Auto-Pressure System

Emergency Operation - Controller Failure

- If Controller loses input of Pump Pressure or RPM, it will not operate.
- Zero Electronic Throttle
- Open LEFT hand side of pump panel .
- Operate **PUMP CONTROL OVERRIDE** Switch.
- Both Main and HP Pumps now operate directly with engine throttle.
- **No Automatic HP Control**
Watch Pressures Closely!



Pull Cover Down



Operate Switch

PSP & Auto-Pressure
Operations Manual DRAFT

Foam-Pro Foam System

- Select Foam Injector
 - “Low Pressure” for
 - Monitor,
 - 70mm outlets
 - Pre-Connect cross-lays.
 - “High Pressure” for
 - Hose Reels



PSP & Auto-Pressure
Operations Manual DRAFT

Foam-Pro Foam System

- Select Flow meter (Appropriate HP or LP Injector must also have been selected)
 - A Monitor,
 - B Nearside 70mm outlets and/or Pre-Connect cross-lays.
 - C HP Hose Reels



PSP & Auto-Pressure
Operations Manual DRAFT

Foam-Pro Foam System

- To select Induction rate & Start Foam:-
 - Press SELECT button until indicator is at “0%”
 - Check this is 0.3%, or adjust to required rate using ↑ ↓ buttons.
 - Press FOAM button to commence injection.





PSP Main Pump

To set Discharge Relief Valve

- CHECK RV SHUT-OFF IS FULLY OPEN
- TURN HI-LO CONTROL FULLY TOWARDS "HI"
- RELIEF VALVE CONTROL "ON"
- RUN PUMP AT MAXIMUM DESIRED PRESSURE.
- TURN HI-LO CONTROL TOWARDS "LO" UNTIL OPERATING PRESSURE IS "TOUCHED" AND RELIEF VALVE OPENS ("OPEN" LIGHT ON)
- TURN CONTROL PART TURN TOWARDS "HI" UNTIL VALVE CLOSES. ("CLOSED" LIGHT ON)
- THE RELIEF VALE IS NOW ACTING AS A MAXIMUM PRESSURE BY-PASS FOR MAIN PUMP.



PSP & Auto-Pressure
Operations Manual DRAFT



RELIEF VALVE SHUT-OFF

- NEARSIDE PUMP PANEL HAS EMERGENCY SHUT-OFF CONTROL FOR DISCHARGE R.V. (BLACK)
- IF DISCHARGE R.V. OPENS WHEN NOT WANTED, IT CAN BE DE-ACTIVATED BY SCREWING CLOCKWISE TO CLOSE THE R.V.
- THIS NEUTRALIZES ANY AUTOMATIC R.V. OPERATION AND PERMITS PUMP PRESSURE TO BE MAINTAINED.
- MONITOR PRESSURE CLOSELY.





PSP Main Pump

Suction Relief Valve

- THESE VALVES RELIEVE EXCESSIVE INCOMING PRESSURE ON FEEDER LINE.
- FED FROM A DUCT ON THE SUCTION NIPPLE OUTSIDE INTAKE BUTTERFLY VALVE
- ADJUSTABLE BY WORKSHOP BUT NOT IN THE FIELD.
- THE VALVE WILL RELIEVE IF INCOMING PRESSURE “SPIKES” ABOVE SETTING
- FACTORY SET TO 1200 Kpa
- DISCHARGE BEHIND REAR WHEELS.



PSP & Auto-Pressure
Operations Manual DRAFT



PSP & Auto-Pressure PUMP DRAIN VALVES

- BELOW AND FORWARD OF EACH PUMP PANEL IS MULTI-PORT DRAIN VALVE.
- NEAR SIDE VALVE DRAINS “LOW POINTS” OF MAIN PUMP INSTALLATION.
- OFFSIDE VALVE DRAINS H.P. PUMP
- WHEN FREEZING IS A THREAT OR BEFORE MAINTENANCE, OPEN VALVE AND WATCH UNTIL WATER CEASES TO FLOW TO GROUND
- SHUT VALVE AND CHECK. - OTHERWISE PUMP WILL NOT OPERATE AT NEXT INCIDENT.



Appendix 2: Hand signals

Raise



Arm extended, fingers closed, thumb pointing upwards.

Lower



Arm extended, fingers closed, thumb pointing downwards.

Released under the Official Information Act 1982

Extend



(Telescoping Boom/ Ladders) Both Fists in front of body with thumbs pointing outward.

Retract



(Telescoping Booms/Ladders) Both fists in front of body with thumbs pointing towards each other.

Rotate



Arm extended, point finger in direction of swing of boom.

Stop



Arm extended, palm vertical with fingers spread.

Hooked on aerial and ready to go



Arm extended, thumb inside closed fist.

Released under the Official Information Act 1982

