



AUCKLAND HARBOUR BRIDGE ACTIVE MODE PROVISION – TRAFFIC IMPACT ASSESSMENT PHASE 1

s 9(2)(a)

20 JUNE 2022

REVISION 2 – FINAL

DOCUMENT CONTROL
REPORT

This report has been prepared for the benefit of the NZ Transport Agency (NZTA). No liability is accepted by the Auckland System Management Alliance (ASM) or sub-consultant of the ASM, with respect to its use by any other person.

DISCLAIMER

The NZ Transport Agency has endeavoured to ensure material in this document is technically accurate and reflects legal requirements. However, the document does not override governing legislation. The NZ Transport Agency does not accept liability for any consequences arising from the use of this document. If the user of this document is unsure whether the material is correct, they should refer directly to the relevant legislation and contact the NZ Transport Agency.

QUALITY ASSURANCE

QUALITY ASSURANCE STATEMENT

Owner: s 9(2)(a) Prepared by: s 9(2)(a)
 Review QA approval by: s 9(2)(a)

REVISION CONTROL

Revision	Name	Date	Description
1.0	s 9(2)(a)	24/06/2021	Draft for discussion
2.0		20/06/2022	Final version with following updates / changes: <ul style="list-style-type: none"> - "Phase 1" added to report title - Addition of Executive Summary - Completion of section 4.3 - Completion of section 5, including addition of Figures 14, 15 and 16 - Section 8.3 – completed 1-page results summary for option 12 – marathon layout - Re-wording of section 8.4 - Completion of section 8.5 - Addition of Section 9 – Conclusions

RELEASED UNDER THE OFFICIAL INFORMATION ACT 1982

EXECUTIVE SUMMARY

The AHB currently operates largely free of congestion (including during peak periods) as a consequence of upstream “strategic” bottlenecks that throttle the arrival of traffic to the bridge. This current situation aligns well with the Auckland Network Operating Plan the Auckland Motorway Operational Strategy that is currently being developed as it supports prioritising the Level of Service of the Rapid Transit Network that runs in general traffic lanes over the bridge in each direction.

The assessment considered the potential impacts on general traffic of 11 different options for an active mode facility on the AHB through re-allocation of existing lane space. The options were a range of temporary and permanent, 1-lane and 2-lane options. Temporary options (which would be installed at weekends and then removed by Sunday evening) were assessed based on typical pre-COVID Sunday trip demands. Permanent options were assessed using typical pre-COVID weekday trip demands.

All options will result in a shortfall of general traffic capacity when considered against typical pre-COVID trip demand levels. There will be two, interrelated responses of the transport system to this demand-capacity mis-match: demand changes (which will reduce the magnitude of the capacity shortfall) and traffic congestion (as the remaining capacity shortfall generates traffic queues from the bridge that propagate upstream over time impacting adjoining sections of the motorway and potentially adjoining arterial and local roads). Both effects were considered in the assessment.

The primary demand changes considered were re-routing and re-moding. Some level of trip cancellation was considered through Working From Home (WFH), based on assuming the persistence of the level seen in March 2021. Trip re-timing and peak spreading was not directly considered given its limited potential due to relatively high inter-peak demands on AHB (in other words the AHB will be overcapacity in the inter-peak period for all options that reduce the overall number of traffic lanes).

The proposed Active mode facility was assumed to attract an average demand of between 1,000 and 3,000 trips per day in the first couple of years. The main factor likely to mitigate traffic impacts however is mode shift to PT, which was assessed at 4 levels from 2,000 to 11,000 trips per day (this did not consider any capacity constraint on PT services, or deterioration of PT Level of Service or reliability due to increased delays encountered on the AHB and its approaches due to the loss of lane capacity).

The traffic congestion impacts of the resulting reduced demands were assessed using the ASM macrosimulation model of the motorway network, which uses a continuous 24-hour modelled period and accurately captures the formation of congestion and its upstream propagation and recovery over time.

The temporary (weekend) options are likely to lead to extensive congestion over much of the day (8 hours or more), primarily on SH1. For the 1-lane options this is confined to southbound on the northern motorway and is likely to extend past SH18 interchange. For the 2-lane option significant queues are likely to occur across much of the day: southbound on the northern motorway extending past SH18 interchange; and northbound on the southern motorway extending past Mt Wellington at their peak. Much lower impacts would be likely to occur with the short duration southbound closure of 2 lanes using the configuration employed for Auckland Marathon (re-opened by 12pm). This would be likely to result in queuing on the southbound approach to the AHB only over approximately 4-hours and extending to around Tristram Avenue interchange at its peak.

The permanent (weekday) 2-lane options would be expected to lead to a significant increase in network congestion - over a doubling of current weekday motorway network delay hours levels over the whole day. The majority of the impacts would be on SH1 corridors approaching the AHB but would also extend onto other motorway corridors, dependent to some extent on the level of re-routing to SH18 to use the Upper Harbour bridge. However, given the large capacity shortfall these options create compared to current (pre-COVID) demand levels and the limited time for the study, the level of confidence in the traffic demand reductions used for assessing the 2-lane options is relatively low and warrants further consideration.

The permanent (weekday) 1-lane options would be expected to lead to a more modest, but still significant increase in congestion across the motorway network (between 17% and 70% increase in motorway network delay hours). For the best performing of the 1-lane options there is no significant impact in the AM peak, but increased congestion in the PM on both the northern and southern motorway corridors approaching the bridge. On the northern motorway this starts in the interpeak and extends into the PM peak. On the southern it starts around 3pm with queues exacerbating the major bottleneck at Green Lane once they reach there. This indicates the lack of interpeak capacity on the AHB may be the underlying issue for the 1-lane permanent options. Further investigation into likely achievable capacities on the AHB and its approaches

with proposed layouts for the active facility, along with consideration of day-to-day demand variability would be required to better understand the potential magnitude of impacts.

Predictably option 11 (the only option without a reduction in the number of traffic lanes) has the least impact on general traffic (a modest 8% increase in motorway network delay hours across the day). The assumed demand reductions offset capacity loss in the direction of predominant demand, and sufficient interpeak capacity remains to prevent inter-peak congestion running into the PM peak. However, a loss of some capacity for the 3-lane configuration is likely to lead to some increase in congestion in the counter-peak direction (northbound in the AM peak, southbound in the PM peak). This is due to the likely layout changes required to accommodate the active facility on each clip-on.

A further consideration for all options that reduce the number of traffic lanes is the loss network resilience this would bring. Incidents block one or more lanes on the AHB during, or in the lead up to, peak periods relatively frequently (at least once every 2-3 weeks). With any reduction of traffic lanes this will lead to longer resulting queues and a longer time for network operation to return to normal once all lanes are re-opened.

RELEASED UNDER THE OFFICIAL INFORMATION ACT 1982

CONTENTS

Executive Summary	3
1 Purpose	6
2 Scope	6
3 Auckland Harbour Bridge – Operational Context	7
4 Auckland Harbour Bridge - Traffic Demand and Capacity	10
4.1 Current Operation.....	10
4.2 Traffic Capacity of Cycle Lane Options.....	14
4.3 Demand changes expected over the next few years.....	18
5 Review of Previous Lane-Reducing Events	20
5.1 The Auckland Marathon.....	20
5.2 September 2020 truck strike incident.....	23
6 Tools to Predict Traffic Impacts...and Their Limitations	27
7 Effects on Traffic Demand	30
7.1 Mode shift to active modes.....	30
7.2 Mode shift to PT.....	30
7.3 Trip Re-routing and Re-timing.....	31
7.4 AHB traffic demand reductions assumed in the assessment.....	31
8 Effects on Network and Customer Journeys	34
8.1 Note of Caution.....	36
8.2 Overall magnitude of Congestion Delay Impacts.....	36
8.3 Distribution of congestion and delay impacts.....	37
8.4 Effects on Network Resilience.....	47
8.5 Observations on AHB peak flows from recent data.....	47
9 Conclusion	48

RELEASED UNDER THE OFFICIAL INFORMATION ACT 1982

1 PURPOSE

The purpose of this report is to inform Waka Kotahi and its operating partners of the likely impacts on traffic of introducing provision for active modes on the Auckland Harbour Bridge.

2 SCOPE

This document has been developed as a reference traffic impact assessment, to enable further discussion of possible tactical operations for the enablement of active modes across the Auckland Harbour Bridge. The elements discussed in this document are explorative and have been developed for the purpose of discussion only.

RELEASED UNDER THE OFFICIAL INFORMATION ACT 1982

3 AUCKLAND HARBOUR BRIDGE – OPERATIONAL CONTEXT

The Auckland Harbour Bridge (AHB) is part of the Auckland motorway system, which comprises five motorway corridors which directly interconnect with each other: SH1 northern; SH1 southern; SH6; SH18 and SH20 (with spurs SH20A and SH20B connecting to the airport).

SH1 is the spine of the motorway system running south from Puhoi via the North Shore, Auckland City Centre and Manukau to Bombay where it enters the Waikato region. The Western Ring Route (WRR) is an alternative to the SH1 spine and comprises SH18 between the North Shore and Westgate, part of SH16, and SH20¹. Both SH1 and the WRR have Important national strategic roles to facilitate the movement of people, goods and services within the greater Upper North Island. With completion of the Northern Corridor Improvements (NCI) project at the interchange of SH18 and SH1 northern all connections between corridors will be via dedicated motorway-to-motorway links.

Auckland's unique geography means the region naturally divides into four main sub-regional sectors separated by bodies of water that reflect the old pre-Auckland Council Territorial Local Authority boundaries: North; West; Isthmus and South. It is operationally significant that the motorway network provides the primary (and in some cases the only) road connectivity between the regional sectors via five strategic crossing locations. The Auckland Harbour Bridge forms one of the strategic crossings along with the SH18 Upper Harbour bridge, SH16 Causeway, SH20 Manukau Harbour crossing and SH1 at Mt Wellington.

Based on this geography, the national strategic role and the first decade strategic modal networks defined by Auckland Transport's Future Connect, the structure and function of the motorway system is summarised in Figure 1.

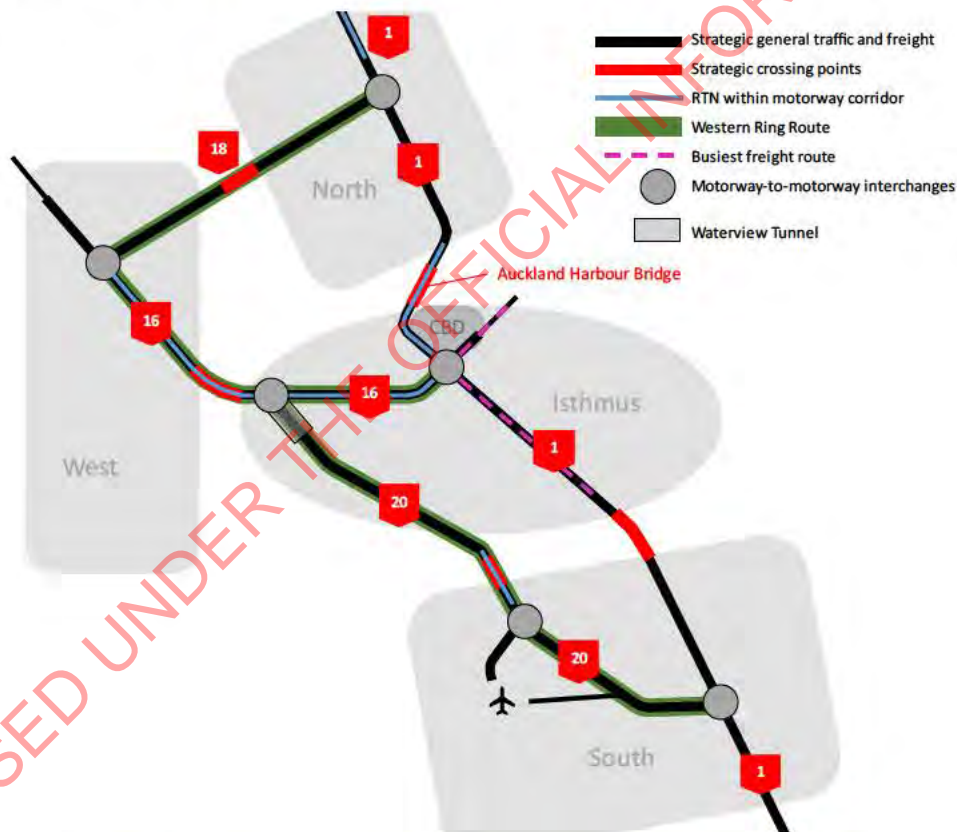

Figure 1 - Auckland motorway network summary of network function

The motorway system typically services a daily traffic demand of around 12.5 million vehicle-kilometres on a typical weekday (equating to around 1.3 million person-trips per day). Peak weekday traffic demands on the motorway system significantly exceed its capacity, leading to extensive daily congestion.

¹ Note that while SH16 between the CBD and where it is joined by SH20 at Waterview is not formally part of the WRR, in practice it is often used to fulfil the same strategic alternative route function when major incidents occur on the Northern Motorway (SH1).

Based on available data sources the ASM has derived a graph which relates the level of daily motorway demand (in terms of the number of vehicle-kilometres travelled on the motorway network) to the level of customer delay hours per day due to congestion on the motorway mainline, across the entire motorway network (in terms of journey delays over and above free flow) to, see Figure 2. This graph essentially depicts the daily supply curve of the motorway for general traffic movement – representing overall network capacity. At demand levels below 10 million vehicle-km per day no significant delays occur anywhere on the network at any time of day. The network reaches capacity around 10-11 million vehicle-km per day. As daily demand rises beyond 11 million vehicle-km per day, daily congestion rises exponentially. Typical motorway network delays ranged between 20,000 and 50,000 person-hours on weekdays in 2019.

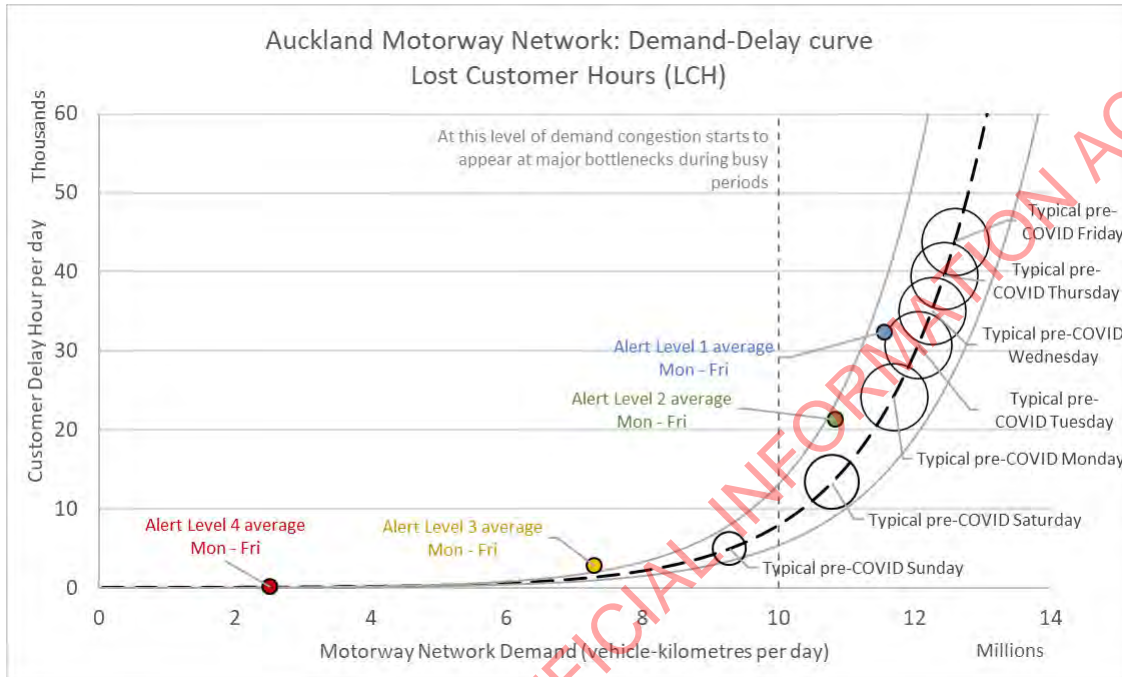

Figure 2 – Motorway network daily Demand-Delay curve

The internal interconnectivity of the motorway system means all journeys on the motorway system enter from and leave to other parts of the transport system in the same way: entering via on ramps and exiting via off ramps that interface with the arterial network. This allows the use of a very simple analogy to articulate the operation of the motorway system under high traffic demands: The Bathtub Theory.

The bathtub theory of congestion was originally attributed to the economist William Vickery, who is said to have arrived at it through casual observation looking down onto the Manhattan road network in the afternoon rush hour from his downtown office window. He likened the growth of traffic queues as large numbers of vehicles exited car parks (resulting in accumulation of more and more traffic on the city streets) to water filling a bathtub, with the gradual exit of traffic over bridges connecting Manhattan to the mainland as water flowing out of the plug outlet.

This analogy can be applied to the whole Auckland motorway system with its contiguous, interconnecting corridors. Think of the bathtub as being the motorway network. In the morning rush hour, vehicles join the traffic on the motorway, entering from on ramps. The on ramps correspond to the taps of the bath and the vehicles correspond to the flow of water into the bathtub. The total number of vehicles on the motorway mainline at a single point in time corresponds to the height of water in the bathtub, and the outflow corresponds to cars exiting the motorway via off ramps (with the off ramps corresponding to the plug outlet).

When the demand of trips entering the network during busy periods exceeds the rate at which trips can exit the network the excess demand will be stored somewhere in the motorway system. The number of accumulated vehicles will therefore increase, and this represents congestion and travel delay. This congestion and delay will not be entirely comprised of slow-moving queues: increased density of traffic leads to lower speeds and delays even when traffic is flowing. But the bathtub really starts to fill when more traffic arrives at a location on the network than can smoothly travel through, leading to flow breakdown and the formation of a queue. A location where this happens is called a bottleneck, and once a number of critical bottlenecks on the network start to accumulate queues any further increase in the entry rate leads to the

overall water level of total accumulating traffic rising rapidly. The critical bottlenecks collectively govern the capacity of the network overall and dictate the shape of the curve in Figure 2.

In effect the motorway system operates like a series of inter-connected bathtubs (one for each of the sub-regional sectors), with the strategic crossing locations forming the outlet from one and the major inlet to the next. The Auckland Harbour Bridge is one of these critical outlets in the system.

RELEASED UNDER THE OFFICIAL INFORMATION ACT 1982

4 AUCKLAND HARBOUR BRIDGE - TRAFFIC DEMAND AND CAPACITY

4.1 Current Operation

Prior to COVID-19 the AHB carried daily traffic volumes of between 180,000 and 190,000 on typical weekdays and between 140,000 and 160,000 at weekends. Current demand has returned to around 98% of pre-COVID levels. Vehicle trips across the bridge are more or less evenly split between those to / from the CBD and those to / from SH16 to the west and SH1 to the south.

The eight total lanes of the AHB are arranged in one of three configurations using a Moveable Lane barrier (MLB) system to accommodate different traffic demand patterns in order to facilitate the bridge's role as a critical traffic outlet. Figure 3 summarises the different lane configurations and associated capacities.

		Western clip-on			Main truss			Eastern clip-on				
		Northbound			NB	Reversible	SB	Southbound				
AM	Direction	3 lanes	↑	↑	↑	↓	↓	↓	↓	↓	5 lanes	AM
	Lane capacity (veh/hr) (Max Sustainable Flow-Rate)	5,200	1,800	1,800	1,600	1,800	1,800	1,800	1,800	1,800	9,000	
Inter peak	Direction	4 lanes	↑	↑	↑	↑	↓	↓	↓	↓	4 lanes	Inter peak
	Lane capacity (veh/hr) (Max Sustainable Flow-Rate)	7,200	1,800	1,800	1,800	1,800	1,800	1,800	1,800	1,800	7,200	
PM	Direction	5 lanes	↑	↑	↑	↑	↑	↓	↓	↓	3 lanes	PM
	Lane capacity (veh/hr) (Max Sustainable Flow-Rate)	9,000	1,800	1,800	1,800	1,800	1,800	1,600	1,800	1,800	5,200	

Figure 3 – AHB lane configurations and capacities

Note that individual lane capacities vary in some configurations: in a 3-lane configuration the single, narrow, lane on the main truss, captured as a bull run between the bridge structure and the MLB string provides around 12% lower capacity than the other lanes.

There is a second MLB string in St Mary's Bay which varies the lane configuration on approach to the bridge in the northbound direction to match the lane configuration on the bridge. In the PM peak this facilitates the opening of the second (right hand) on ramp at Fanshawe Street which feeds its own lane through St Mary's Bay.

Figure 4 to Figure 6 illustrate typical profiles of flows arriving at the bridge and the lane capacity available on the bridge over the day, by direction for both weekdays and weekends. On weekdays these flows reach the capacity of the bridge in the counter-peak direction (3 lanes) during the peak periods, indicated by the small red sections on the graphs in Figure 5 and Figure 6. In the peak direction at these times (5 lanes) there are upstream capacity constraints where congestion forms - providing a measure of protection against the bridge itself reaching capacity. As a consequence, the flows shown in the graphs do not fully reflect demand at these times, but rather the rate at which traffic can reach the bridge itself (referred to as "arrival flows"). Figure 5 and Figure 6 include lane diagrams of the approaches to the bridge in the peak (5 lane) configurations illustrating the observed flow relative to capacity at these approach constraint locations. Volume-to-Capacity (V/C) ratios in excess of 0.95 are essentially at capacity since capacity in practice is not a fixed value and flows over this level cannot be sustained for long before flow breaks down and congestion starts to form².

In the southbound direction the 5-lane bridge configuration in the AM peak is fed by four lanes upstream – three from downstream of Esmonde Road, plus a lane gain at Onewa Road on ramp. The Esmonde on-ramp merge is one of the primary critical bottlenecks on the motorway network, and along with the 5-lane AM peak configuration on the bridge performs an important strategic function: it ensures no delays to AM peak PT services on the Rapid Transit Network that use general traffic lanes from Onewa Rd to Fanshawe Street. The 4-lane capacity at the Onewa lane gain (immediately prior to the addition of the AM fifth lane on

² Volume-to-capacity ratios more than 1.0 cannot occur in practice. In this situation observed volume is the actual capacity achieved on that day (with the resulting V/C at, or very close to, 1.0). Excess arrival demand then queues upstream of the constraint, waiting to be discharged at the capacity rate – in other words a bottleneck.

the right hand side) exceeds the 4-lane capacity of the bridge itself, due to the bridge approach gradient and high lane changing associated with traffic joining at Onewa Road. As a consequence, the AM peak arrival flows at the bridge exceed the capacity of a 4-lane bridge configuration.

In the northbound direction the 5-lane capacity of the bridge exceeds the 5-lane capacity of St Mary's Bay due to the significant curvature and lane changing of the St Mary's Bay section. However, traffic entering from Curran Street merges into the segregated 2-lane section leading up to the western clip-on of the bridge. The additional input of demand from this on-ramp routinely leads to the 2-lane section reaching capacity during the PM peak - causing localised flow breakdown and congestion while the 3 lanes on the main truss have some capacity remaining. This localised flow breakdown creates minor delays to peak PT services on the Rapid Transit Network that use general traffic lanes on approach to the bridge. Note that since the start of construction of the Northern Corridor Improvements (NCI), capacity constraints associated with the long-term traffic management at this work zone cause extensive queuing on the northern motorway northbound in the PM peak. This often extends back to the bridge and may be limiting the peak flows it achieves and resulting in more extensive congestion through St Mary's Bay. This is expected to reduce once NCI construction completes.

Figure 5 and Figure 6 also illustrate the how many vehicles using the bridge use city exits (southbound) and how many enter from the city (northbound), compared to how many vehicles come from or continue onto the southern and northwestern motorways. Vehicle flows are more or less evenly split both in the peak and over the whole day between those to/from the city and those to/from other parts of the region.

At weekends when the bridge remains in a 4-northbound / 4-southbound configuration from Friday evening to Monday morning, the bridge itself forms the capacity constraint on the SH1 corridor. Demands peak around 6,000 vehicles per hour and are roughly sustained between about 11am and 4pm – meaning there is around half a lane of spare capacity in each direction during this time.

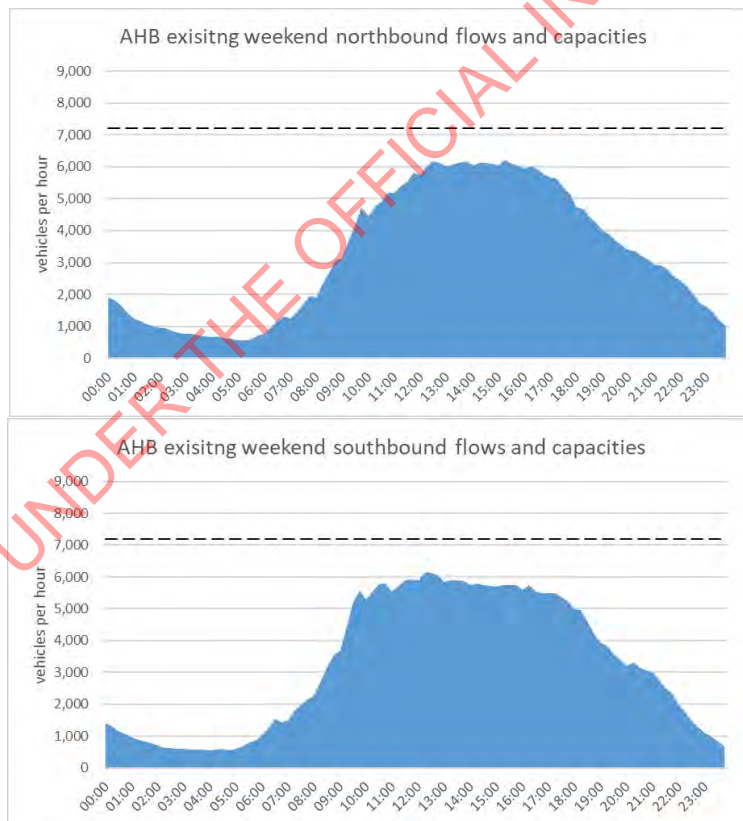

Figure 4 – Summary of typical weekend day northbound (top) and southbound (bottom)

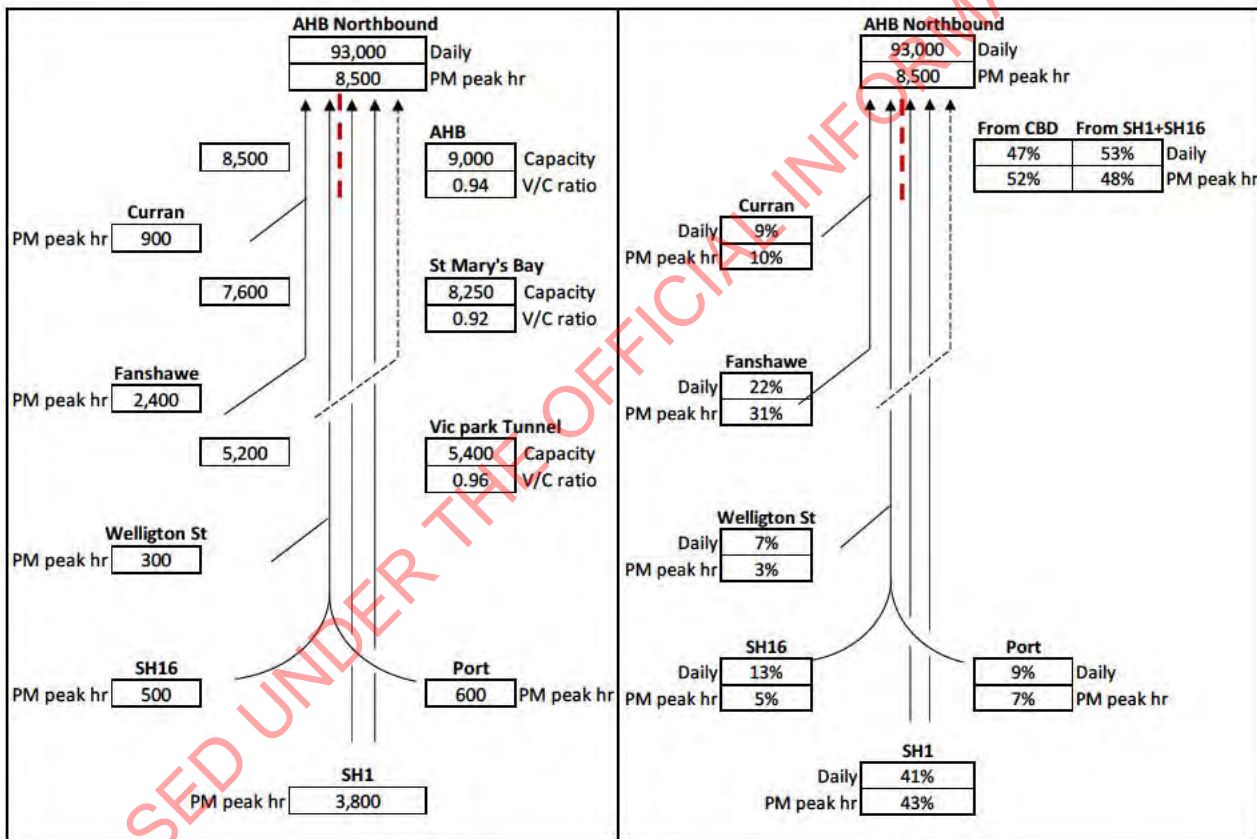
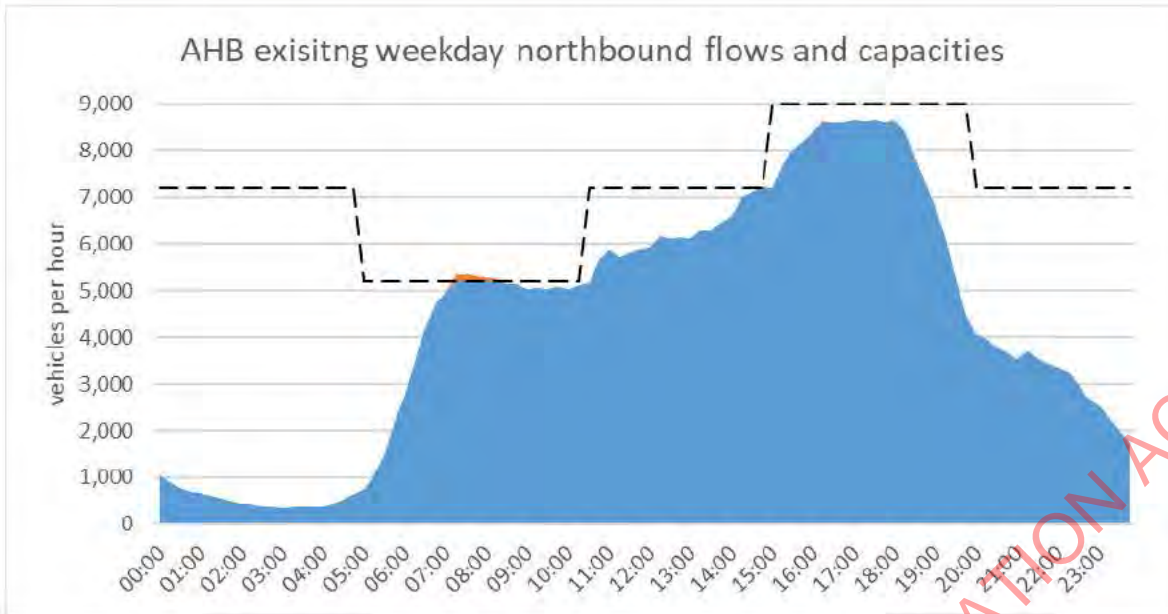

Figure 5 – Summary of typical weekday northbound

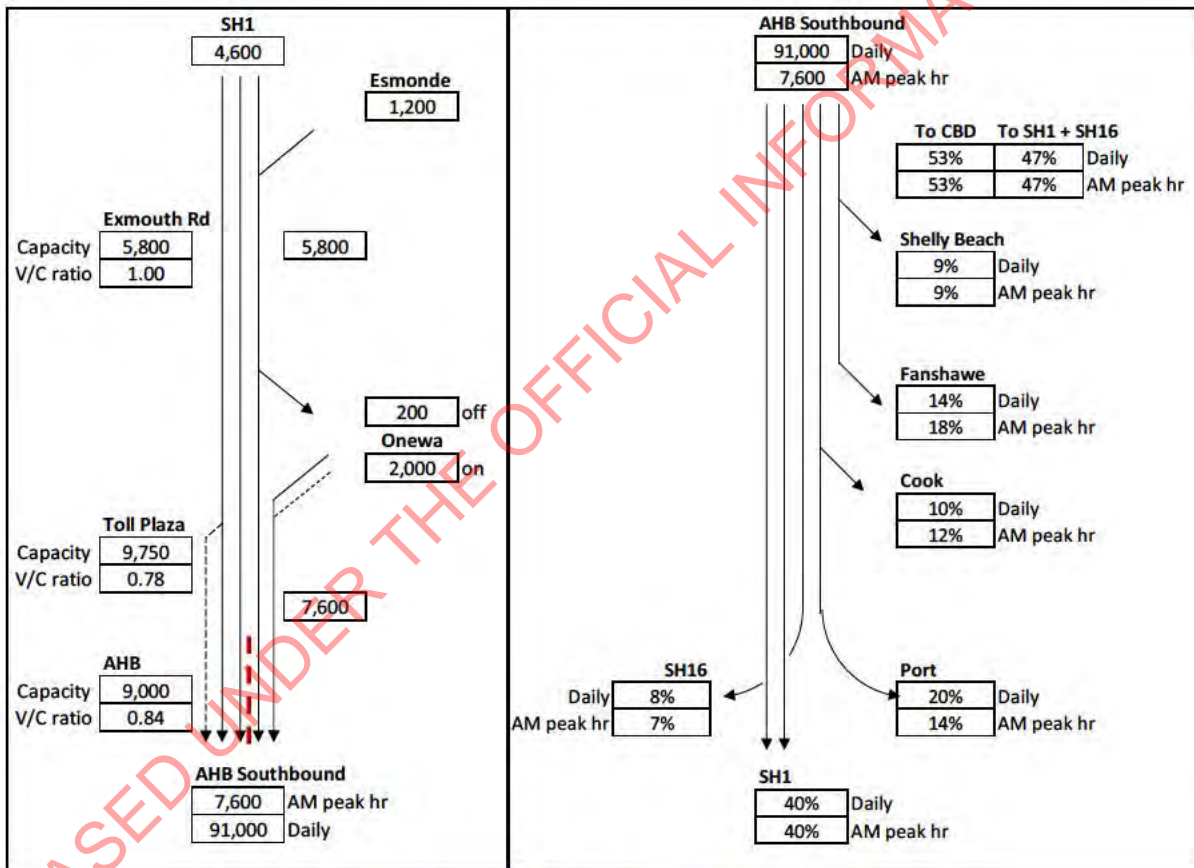
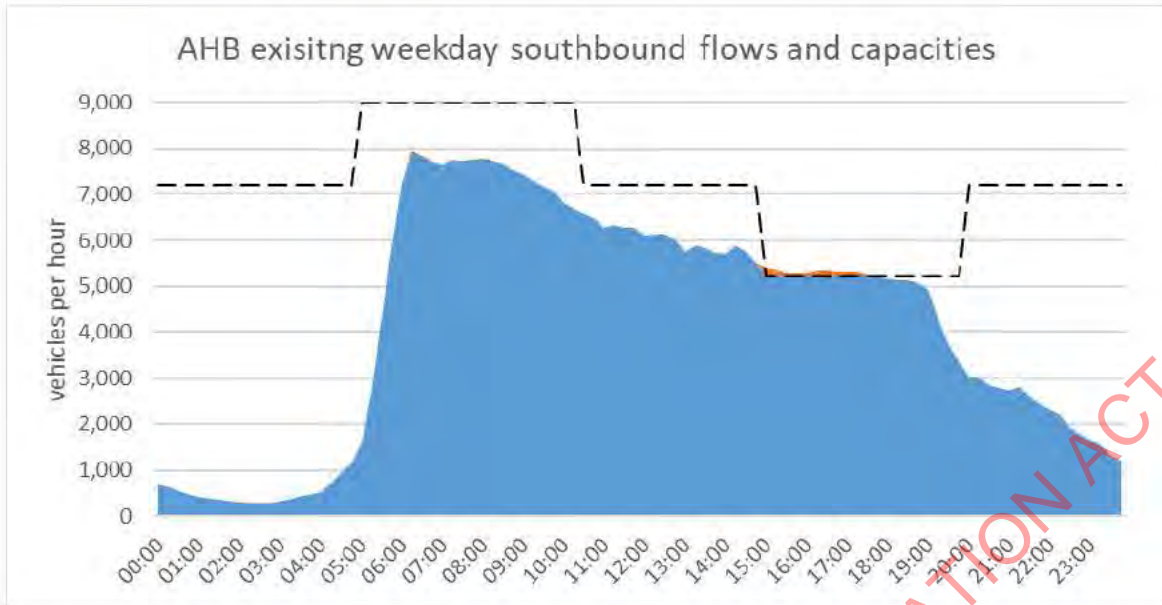

Figure 6 - Summary of typical weekday southbound

4.2 Traffic Capacity of Cycle Lane Options

The options being considered for either a temporary (weekend) or permanent (7 days per week) cycle facility across the AHB are summarised in Table 1.

Table 1 – Summary of AHB cycle lane options

No.	Option Description	Temporary/ Permanent	Ramp Closures	Total traffic lanes	Lane config	Traffic Impact Analysis notes
1	East - 1 Lane	Temporary (Sundays)	Shelly Beach	7	4NB-3SB	Critical SB capacity constraint is merge to 3 lanes under TTM after Onewa on-ramp.
2	East - 2 Lane	Temporary (Sundays)	Shelly Beach	6	3NB-3SB	Critical SB capacity constraint is merge to 3 lanes under TTM after Onewa on-ramp.
5	West - 1 Lane	Temporary (Sundays)	None	7	4NB-3SB	Curran St either merge into single bull run lane or closed. if Curran open, critical NB capacity constraint is Curran merge into single captured bull run lane (this lane will achieve low capacity).
6	West - 2 Lane	Temporary (Sundays)	Curran Street	6	3NB-3SB	Critical NB capacity constraint St Mary's Bay merge to 3 lanes.
12	MARATHON layout	Temporary (Sundays)	Shelly Beach	6	3NB-3SB	All lanes restored by 1pm (cycle lane closes 12pm). Critical SB capacity constraint 2 lanes at Esmonde on ramp merge.
3	East - 1 Lane	Permanent (all days)	Shelly Beach	7	AM - 3NB-4SB PM - 4NB-3SB	Variation 3b. with 5NB-2SB in PM peak.
4	East - 2 Lane	Permanent (all days)	Shelly Beach	6	3NB-3SB	Fanshawe peak lane operates (5 lanes in PM initially in St Mary's Bay). Critical NB capacity constraint St Mary's Bay merge to 3 lanes.
7	West - 1 Lane	Permanent (all days)	Curran Street	7	AM - 3NB-4SB PM - 4NB-3SB	Curran St either merge into single bull run lane or closed. Fanshawe peak lane operates (5 lanes in PM initially in St Mary's Bay). Critical NB capacity constraint St Mary's Bay merge to 4 lanes if Curran closed, NB clip-on lane reduced capacity if Curran open.
8	West - 2 Lane	Permanent (all days)	Curran Street	6	3NB-3SB	Fanshawe peak lane operates (5 lanes in PM initially in St Mary's Bay). Critical NB capacity constraint St Mary's Bay merge to 3 lanes.
9	Centre – 1 Lane	Permanent (all days)	None	7	4NB-3SB	MLB position required to be fixed 24/7
10	Centre – 2 Lane	Permanent (all days)	None	6	3NB-3SB	Analysis of Option 4 adequate to cover this one.
11	Both Sides	Permanent (all days)	None	8	As existing	All clip-on lanes will face 15% reduced capacity due width and shy-line restrictions.

All of the options will lead to lane configurations on the bridge with capacities that are inadequate to accommodate existing peak arrival flows, to a greater or lesser extent. The red sections on the graphs in Figure 7 and Figure 8 below provide a comparative visual guide to the timing and extent of existing arrival flows that would be in excess of bridge capacity under each option.

Some of the graphs represent more than one option because the overall effect on lane capacity is the same irrespective of which side of the bridge the cycle facility is provided. For the purposes of these illustrations it has been assumed that the timing of Moveable Lane Barrier (MLB) shifts would be optimised to minimise the overall extent of the existing arrival flows profile being in excess of bridge capacity considering both directions.

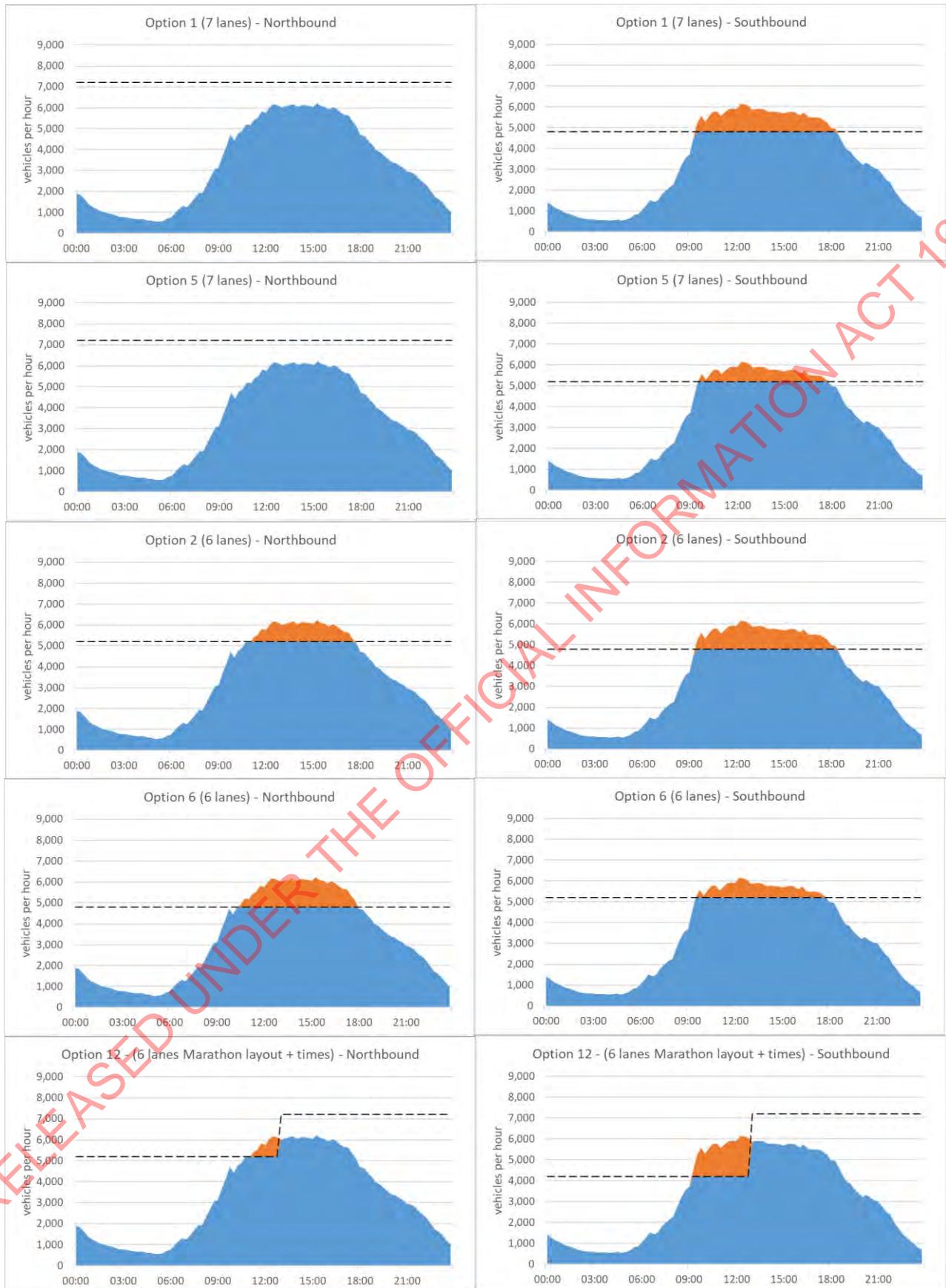

Figure 7 – Demand in excess of bridge capacity – temporary (weekend) options

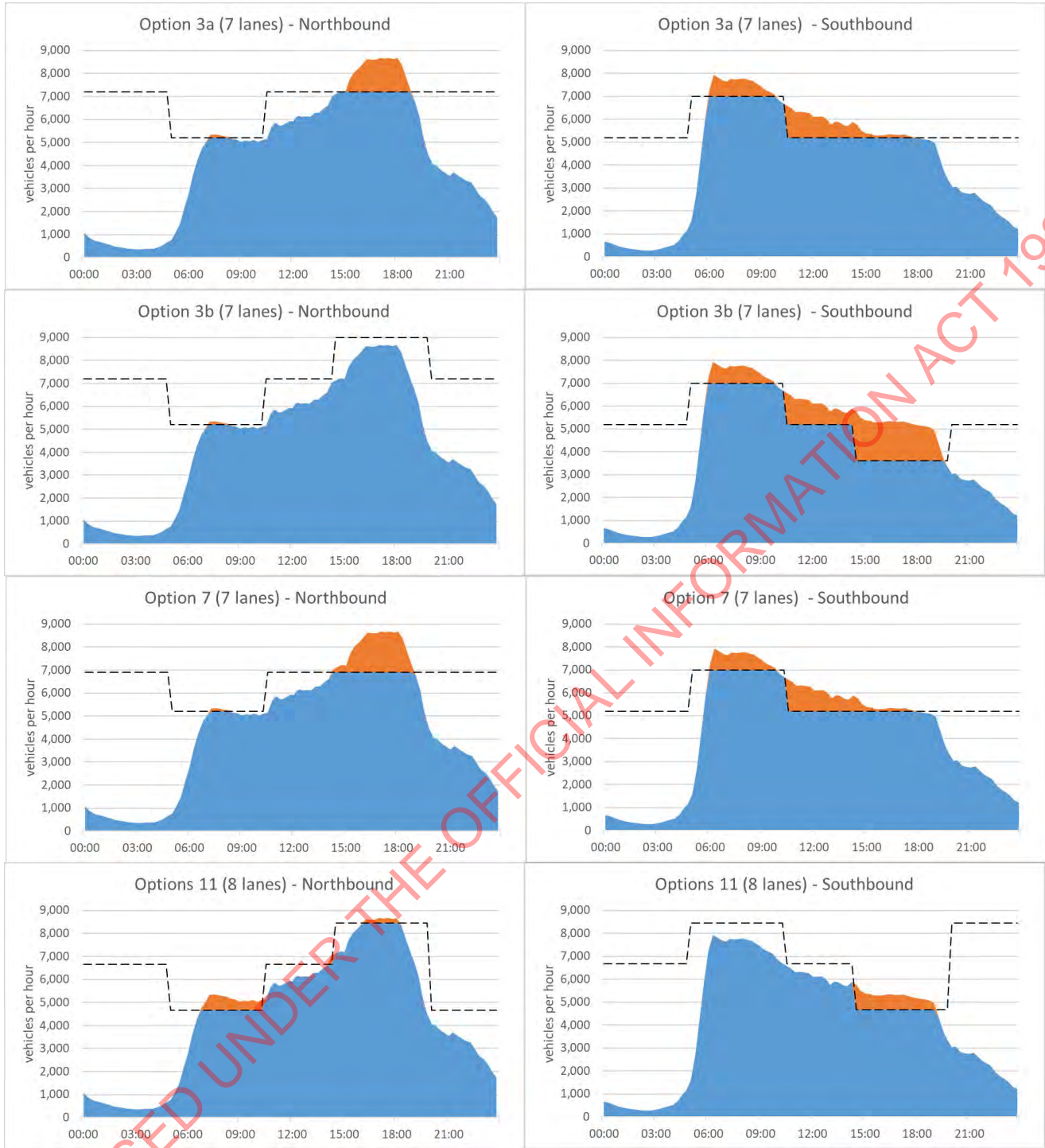

Figure 8 - Demand in excess of bridge capacity – Permanent (7-day) options (continued overleaf)

RELEASED UNDER THE OFFICIAL INFORMATION ACT 1982

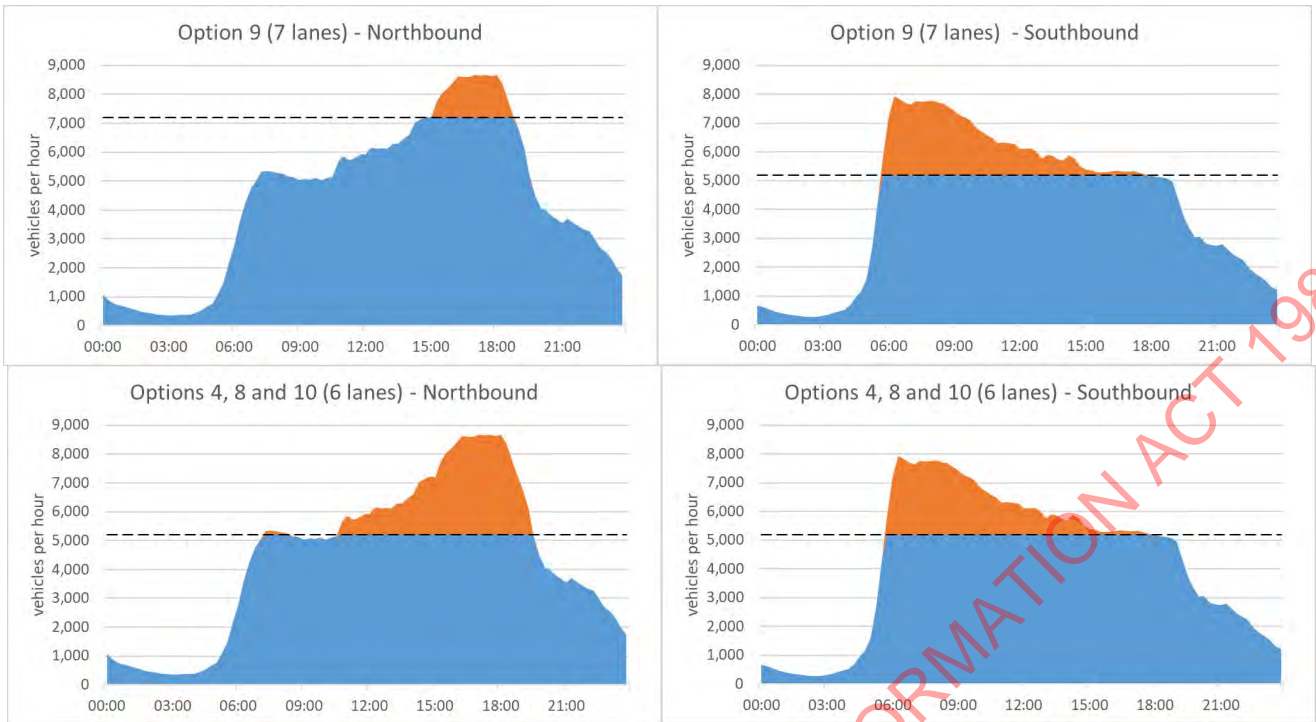

Figure 8 (continued) - Demand in excess of bridge capacity – Permanent (7-day) options

The key question for the traffic analysis is - what will happen to the traffic represented by the red areas if a cycle facility is introduced on the bridge? There are two broad, interrelated responses:

1. **Traffic congestion.** This will be generated on the approaches to the bridge, which will propagate upstream over time impacting adjoining sections of the motorway, city and local roads - creating delays not only for cars, buses and trucks using the bridge but also for other customers caught in the upstream congestion. The congestion will persist until the available bridge capacity is able to clear the backlog.
2. **Demand change.** Some customers affected will choose to modify their trip behaviour to avoid the congestion and delays. This could include choosing the alternative route via SH18, SH16 and SH20, re-timing their trip to a less busy time, choosing an alternative mode of transport (including cycling or walking over the bridge on the new facility), undertaking a different trip that doesn't require crossing the harbour, or cancelling their trip altogether.

Note the following:

- Demand change in terms of mode shift to PT, re-routing to SH18, SH16 and SH20 and re-timing of trips will be driven primarily by increases in congestion. On the other hand, mode shift to active modes will largely be driven by the improved active mode connectivity a cross-harbour facility provides.
- Traffic choosing to re-route via SH18, SH16 and SH20 may increase congestion on these routes, leading to congestion impacts being spread across the wider motorway and arterial networks.

4.3 Demand changes expected over the next few years

AADT traffic volumes over the AHB have been static since 2017, despite continued population growth in this period. The corridor constraints associated with the long-term NCI worksite may be contributing to this through increasing congestion on the corridor. During the same period patronage on the Northern Busway has grown strongly (pre-COVID) and traffic volumes over Upper Harbour Bridge on the SH18 alternative route have continued to grow indicating some demand displacement (see). Note the Waterview Tunnel opened in 2017 which has made the SH18 / SH16 / SH20 alternative route more attractive for some journeys.

Over the expected life of a cycle facility on the bridge there are a number of independent factors that will influence both the overall traffic demand for the bridge and potentially the profile of traffic arriving at the foot of the bridge. The main factors are:

- Population growth over the expected lifespan of the options.
- Changes to the capacity of the Northern Busway over the expected lifespan of the options.
- Continuing impacts of COVID-19 over the expected lifespan of the options (including Traffic Light setting, the emergence of new variants, ongoing reluctance to use public transport).
- Persistence of increased Working From Home (WFH) beyond COVID-19.
- The likelihood of a congestion charge being implemented during the lifespan of the options, the timing of its introduction and the design of the charging scheme

However, given projected regional population growth over the next 10 years (including significant expected growth around Silverdale, Orewa and Warkworth) some further increase in AHB traffic demand should be expected (although likely to be modest compared to historical growth rates pre-2017) – see Figure 10

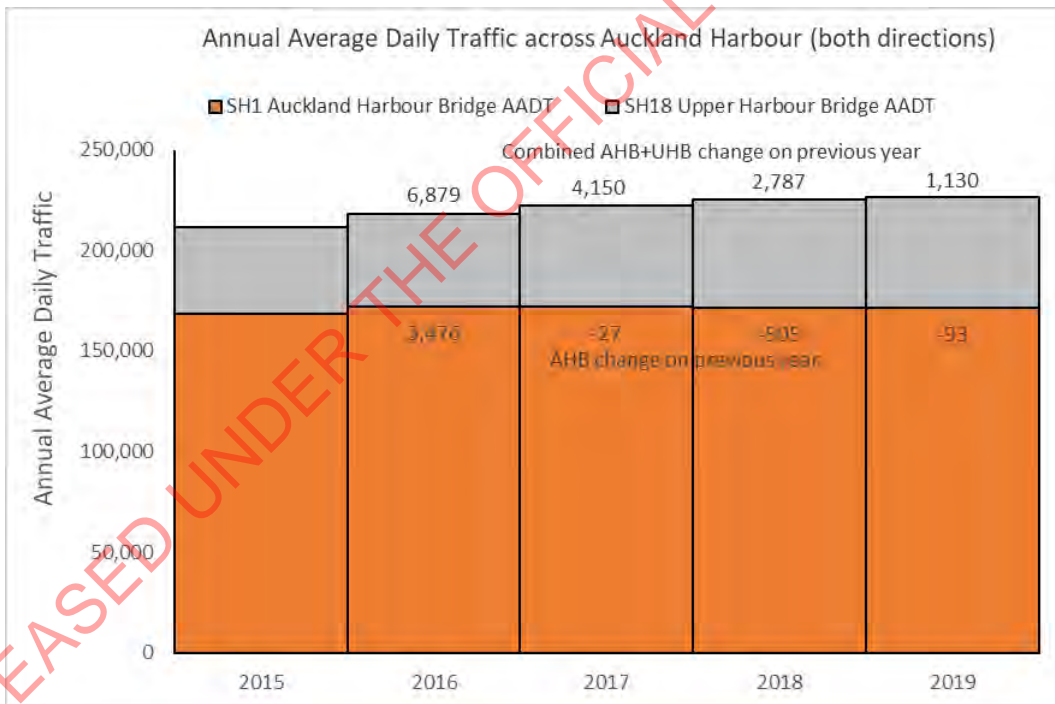

Figure 9 – Recent trends in Annual Average Daily Traffic across AHB and the Upper Harbour bridge (SH18)

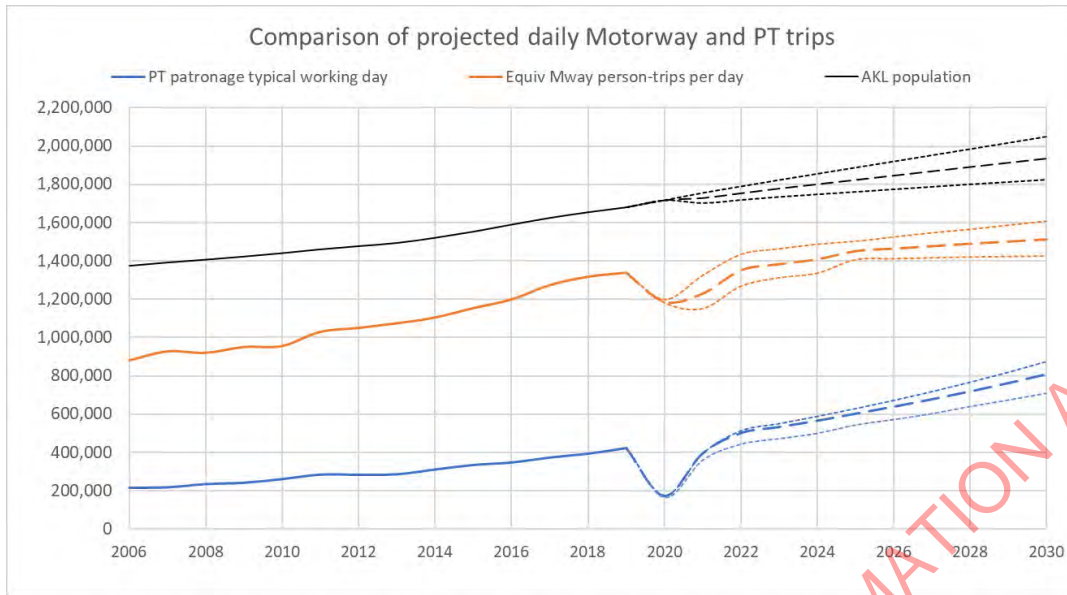

Figure 10 – Projected growth of Auckland population, Motorway trips and PT trips

RELEASED UNDER THE OFFICIAL INFORMATION ACT 1982

5 REVIEW OF PREVIOUS LANE-REDUCING EVENTS

Planned lane closures of the bridge occur frequently to allow maintenance work to be carried out, and crashes and other incidents frequently lead to unplanned lane closures.

However, neither of these types situations provide a useful comparison: planned lane closures occur overnight to avoid traffic impacts (as with the rest of the motorway network) and crashes generally lead to short durations of lane blockage / closure (and incident management protocols are designed to allow lanes to re-open as quickly as possible to minimise traffic impacts).

Planned lane closures of up to two lanes at a time occur each year over the Christmas / New Year period to enable resurfacing of lanes on the bridge. These closures are timed for this period as traffic demands are significantly reduced at this time (down by around a third compared to a typical weekday, and down by around a fifth on a typical weekend).

There are two recent events involving multiple lane closures outside of the circumstances described above that provide some relevance to the options being considered here:

- The 2019 Auckland Marathon
- The September 2020 truck strike incident

Examination of available traffic volume and travel time data during these events provides some insight into the effects of lane closures on the bridge at times when traffic demand exceeds remaining capacity over longer periods.

5.1 The Auckland Marathon

For the marathon event the two southbound clip-on lanes are closed under Temporary Traffic Management (TTM) arrangements for several hours on a Sunday morning – reopening at 11am, leaving six total lanes for traffic until this time. Access to the bridge for runners is via the northern busway (which is also closed from Smales Farm station). To provide safe separation of motorway traffic from runners along the section of southbound bus shoulder lane from Esmonde Road to Onewa Road, a lane drop on the motorway mainline is introduced just before Esmonde on ramp (access via Esmonde on ramp joins lane 2 under temporary arrangements). Onewa road on ramp then joins the mainline as a lane gain to provide the third available traffic lane across the bridge. As a result, the primary restrictions to southbound motorway traffic are at the lane drop prior to Esmonde on ramp, and the merge of Esmonde on ramp with the remaining two lanes – rather than at the bridge itself (see Figure 11).



Figure 11 – schematic diagram of marathon closure layout on SH1 southbound

In the northbound direction the bridge is reduced to three lanes of traffic and Curran Street on ramp is closed, due to Curran Street forming part of the marathon route.

Given the disruption to traffic demand due to COVID during 2020, observed data from the 2019 marathon has been used to review traffic demand and congestion impacts.

The traffic volume graphs and time-space speed heatmaps in Figure 12 and Figure 13 compare traffic on the day of the marathon (20-Oct-19 with the prior Sunday).

SH1 Southbound 2019-10-13 Normal Sunday

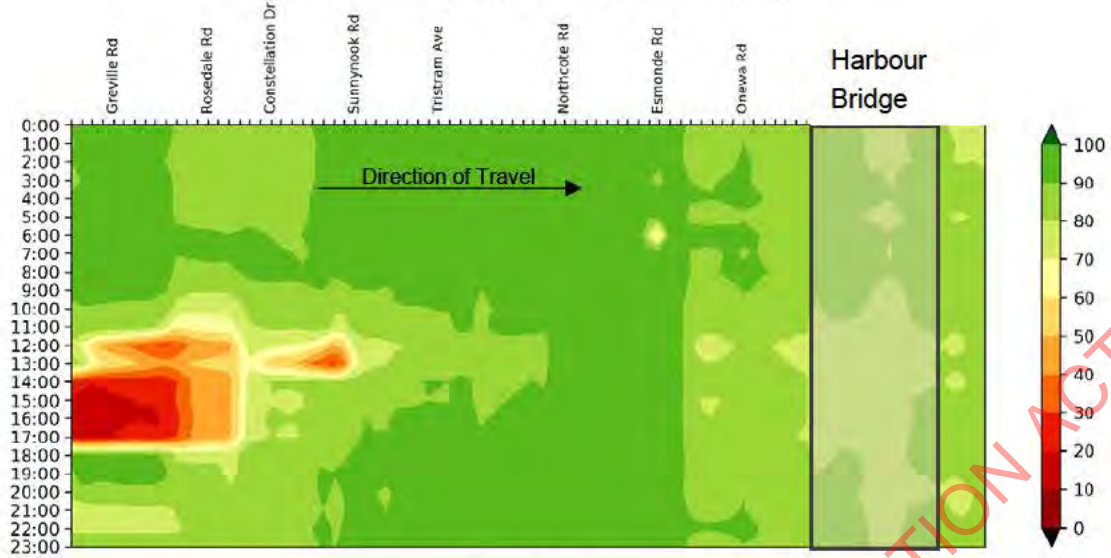

SH1 Southbound 2019-10-20 Marathon Sunday

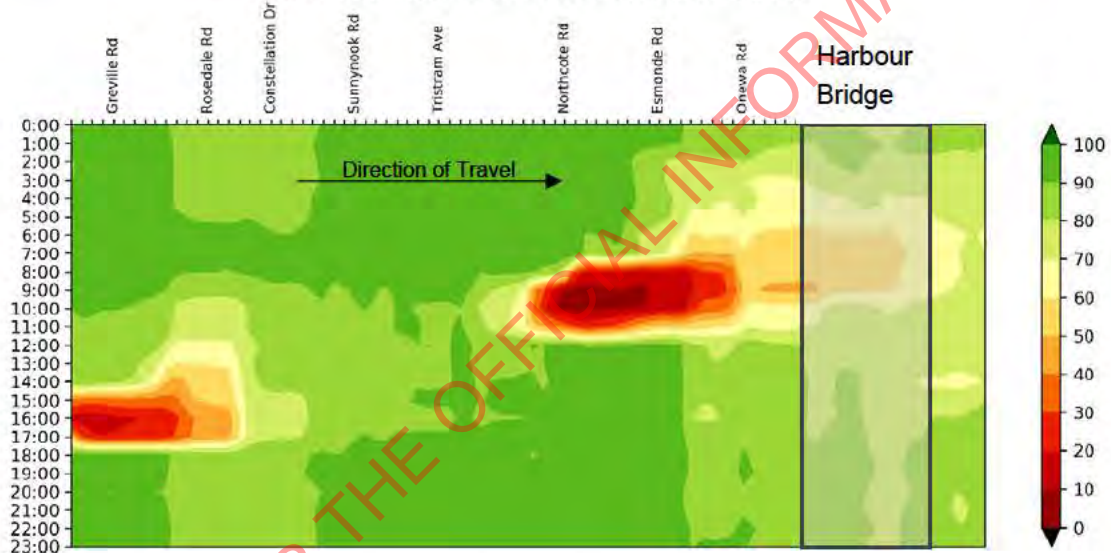

AHB SB hourly volumes

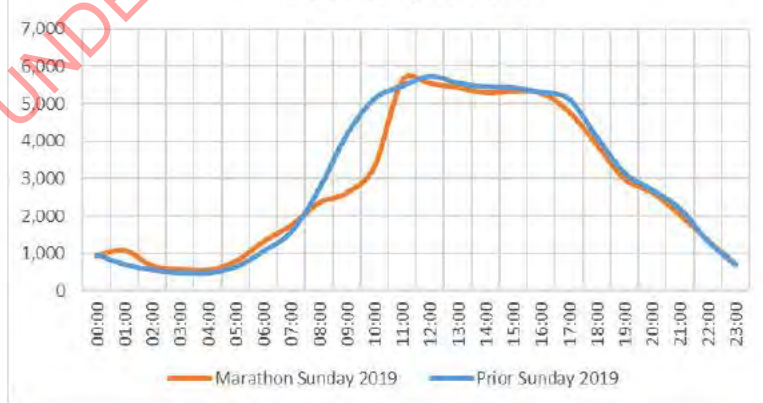
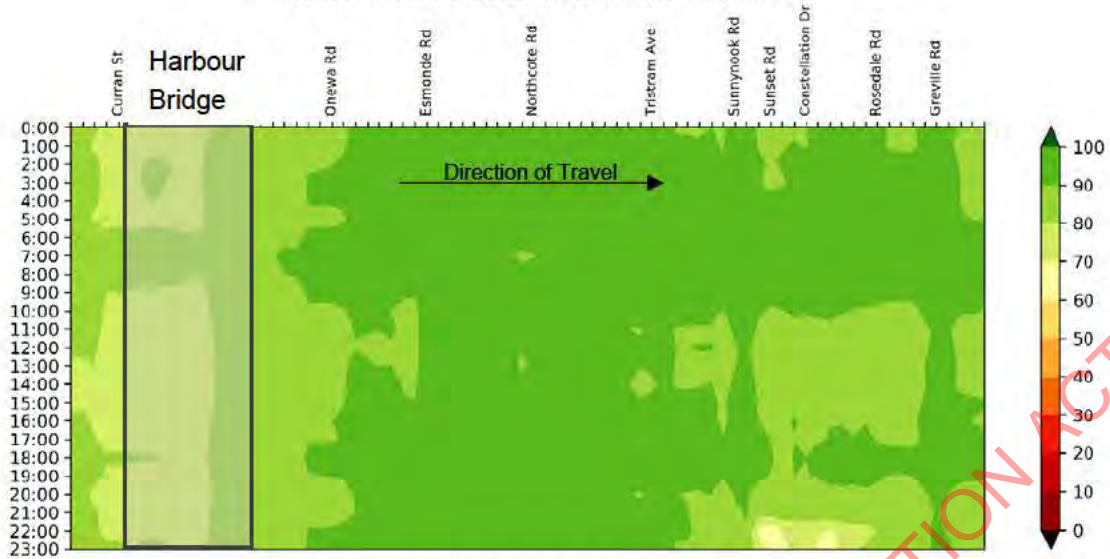
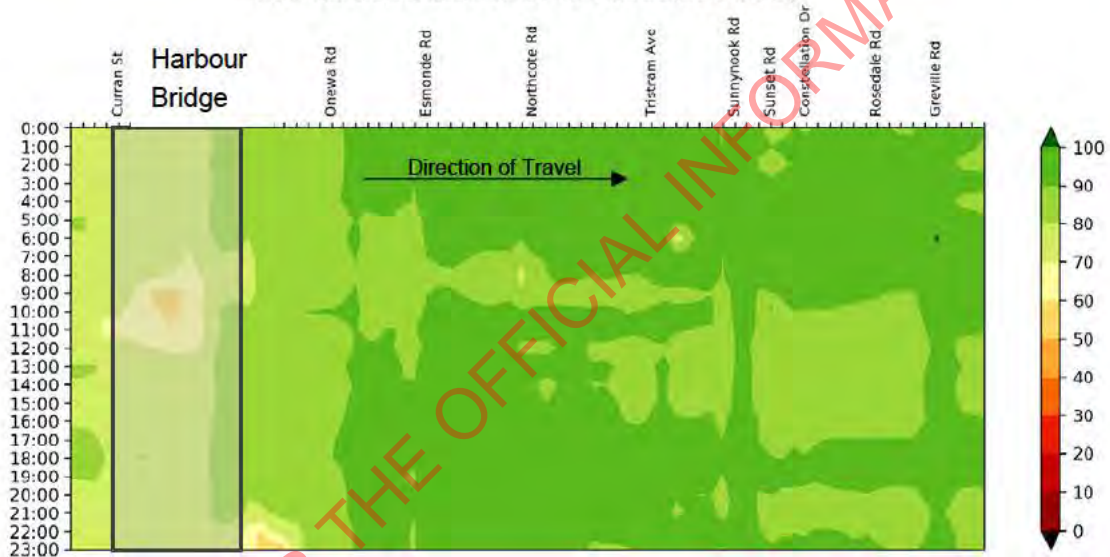

Figure 12 - Auckland Marathon 2019 Traffic Impacts - SH1 SB

SH1 Northbound 2019-10-13 Normal Sunday



SH1 Northbound 2019-10-20 Marathon Sunday



AHB NB hourly volumes

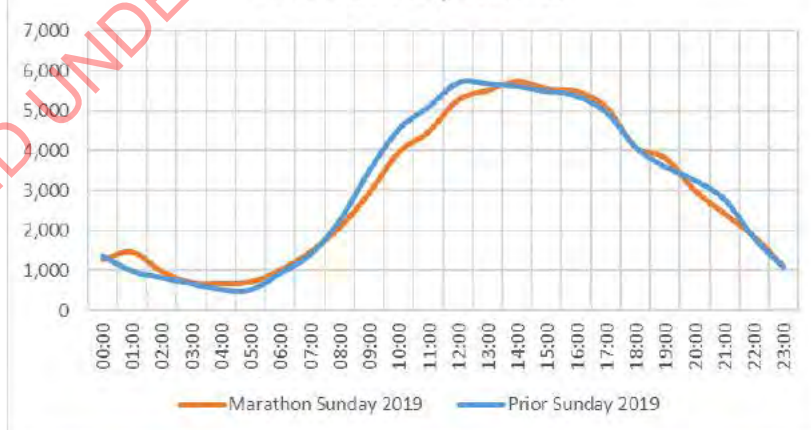

Figure 13 – Auckland Marathon 2019 Traffic Impacts - SH1 NB

No significant congestion was evident in the northbound direction, with all lanes being re-opened before traffic demand exceeded three lanes. Overall northbound traffic demand over 24-hours was down slightly on the prior Sunday, but still at typical levels.

In the southbound direction congestion was evident from around 7.30am to around 12pm, forming at the Esmonde Road lane drop and on ramp merge and extending past Northcote Road. Traffic volumes were significantly below normal between 8am and 11am with 24-hour demand 6% down on the previous week (at about the 20th-25th percentile level for Sundays in 2019). This demand suppression occurred almost entirely between 8am and 11am, although the hourly flows do not tell the whole story. Given the congestion evident the temporary layout was operating over-capacity for 3 hours – therefore the reduced volumes measured at the bridge at this time represent only what able to pass through the temporary layout, not the full demand that wished to.

The highest southbound flow achieved during the closure was around 3,300 vehicles per hour, around the capacity of TWO lanes under TTM, not three. This is significant for any potential use of a similar TTM layout to facilitate a temporary cycle facility on Sunday mornings.

5.2 September 2020 truck strike incident

Following the impact of a truck into its main truss on 18 September 2020, the AHB operated with a reduced number of lanes for a little over two weeks. Initially reduced to just four total traffic lanes for five days, the bridge then operated at six total lanes for a further 11 days, proving a unique opportunity to review reduced capacity operation.

However, as Auckland was in COVID Alert Level 2 during this entire period the data needs to be interpreted with caution: motorway network daily demands were down around 10% on normal during this time and AHB daily demands were down between 8% and 12%. As Figure 2 in section 3 shows, motorway congestion levels were greatly reduced at Alert Level 2.

Figure 14 compares average daily traffic demand across the AHB and the alternative Upper Harbour Bridge (UHB) during the closures to the (Alert Level 2) week prior and also to typical 2019 pre-COVID levels. While two lanes were closed on the AHB daily traffic demands were down almost 30,000 on the week prior to the incident, with an increase of around 10,000 on the UHB – giving a net decrease in cross-harbour traffic of 19,000 vehicles per day.

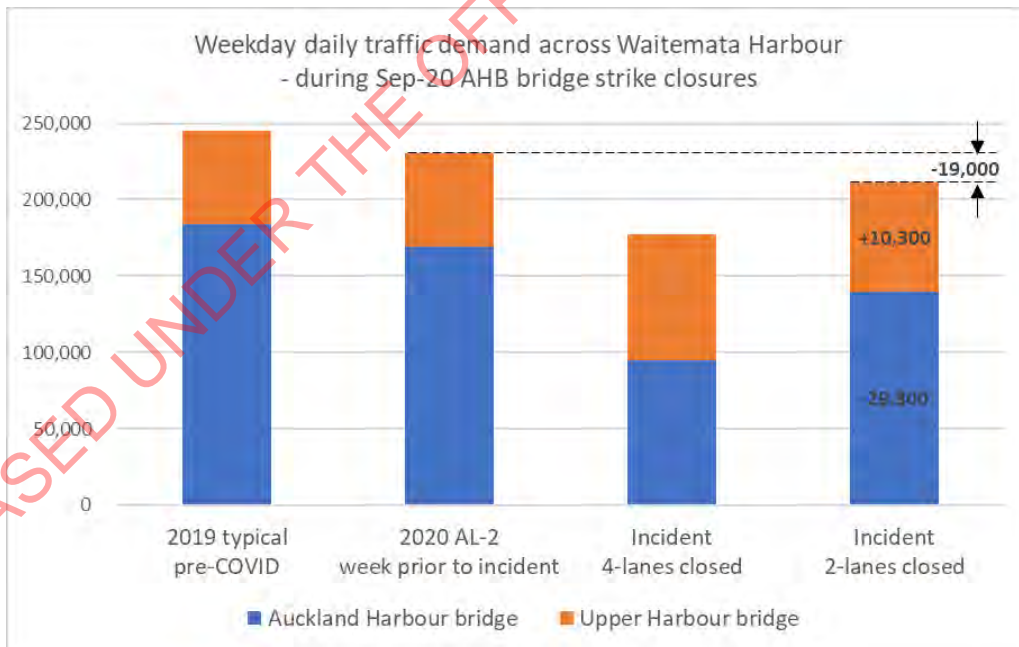

Figure 14 – Daily traffic demand across Waitemata Harbour during Sep-2020 AHB truck strike closures

The time-space speed heatmaps in Figure 15 and Figure 16 indicate the level of traffic congestion impacts on SH1 with two lanes closed - despite this considerable demand reduction.

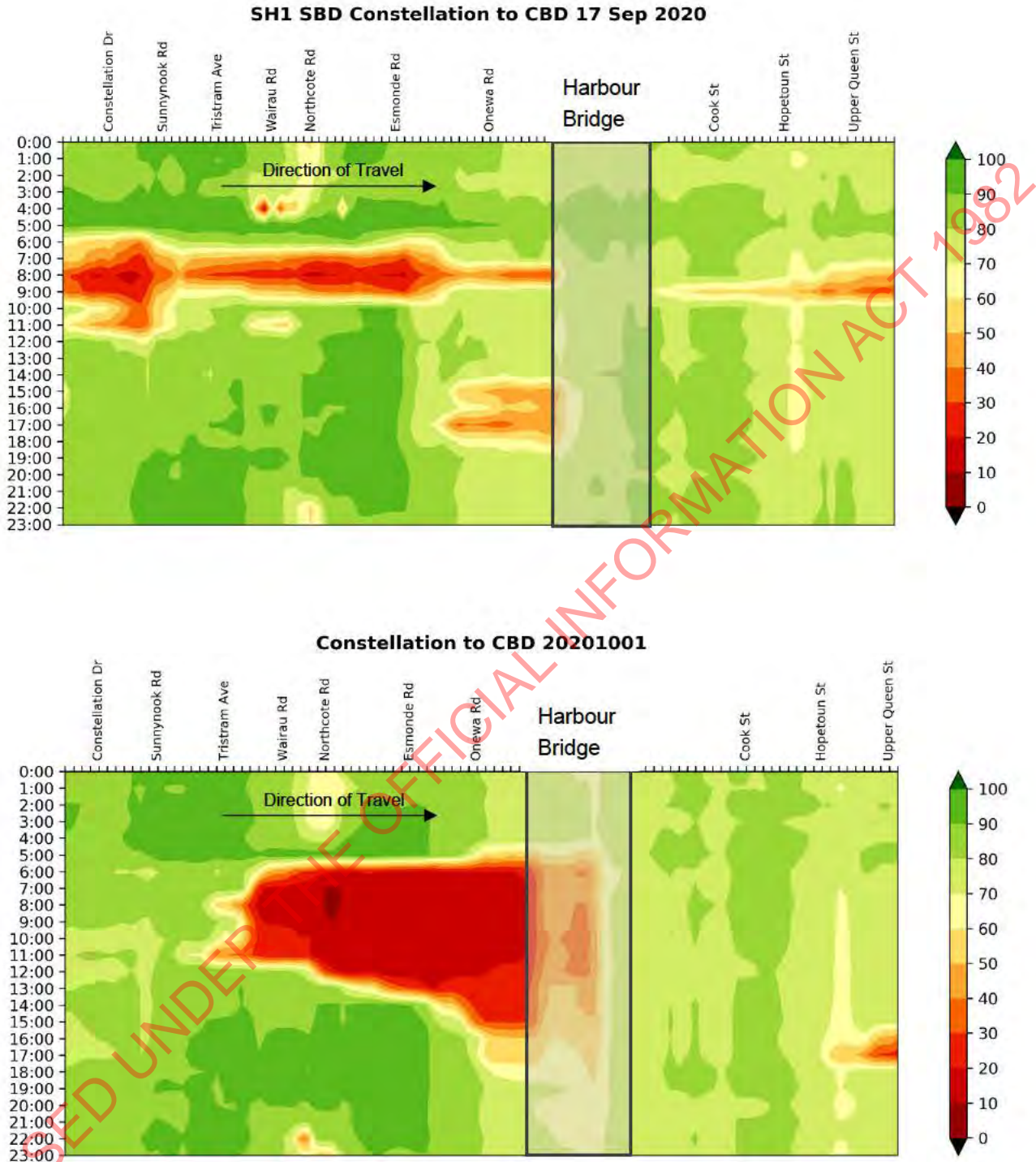
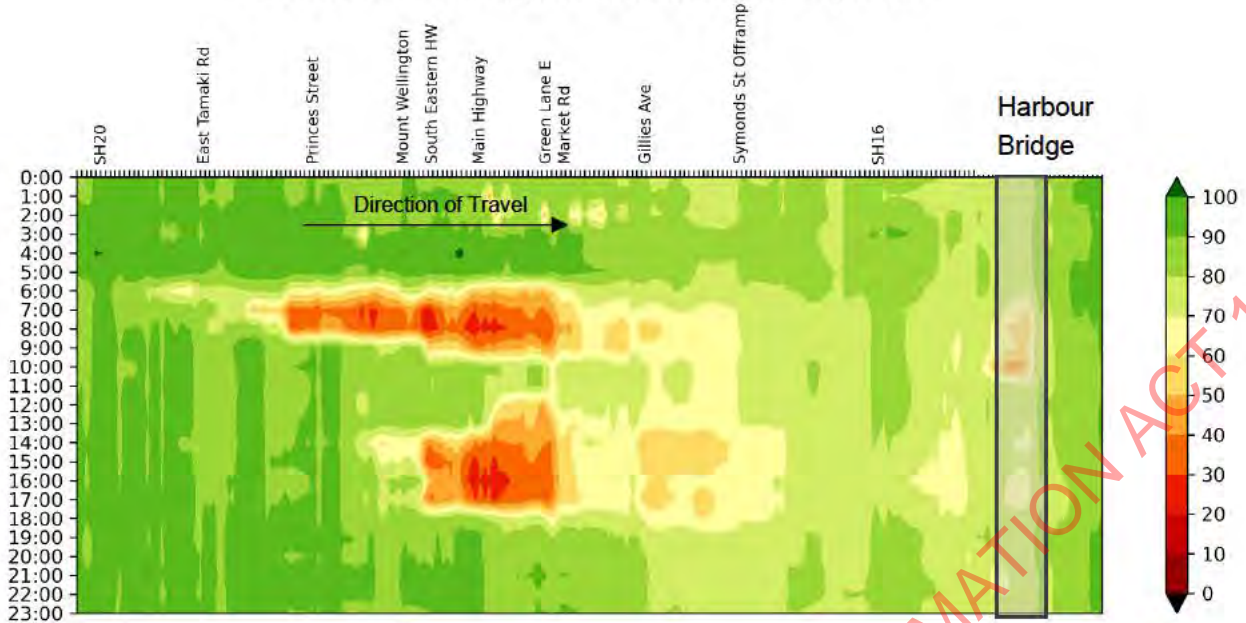

Figure 15 – Sep 2020 truck strike incident SH1 southbound traffic impacts compared the equivalent day in the week prior to the incident

SH1 NBD Mt Wellington to Onewa Rd 17 Sep 2020



SH1 NBD Mt Wellington to Onewa Rd 1 Oct 2020

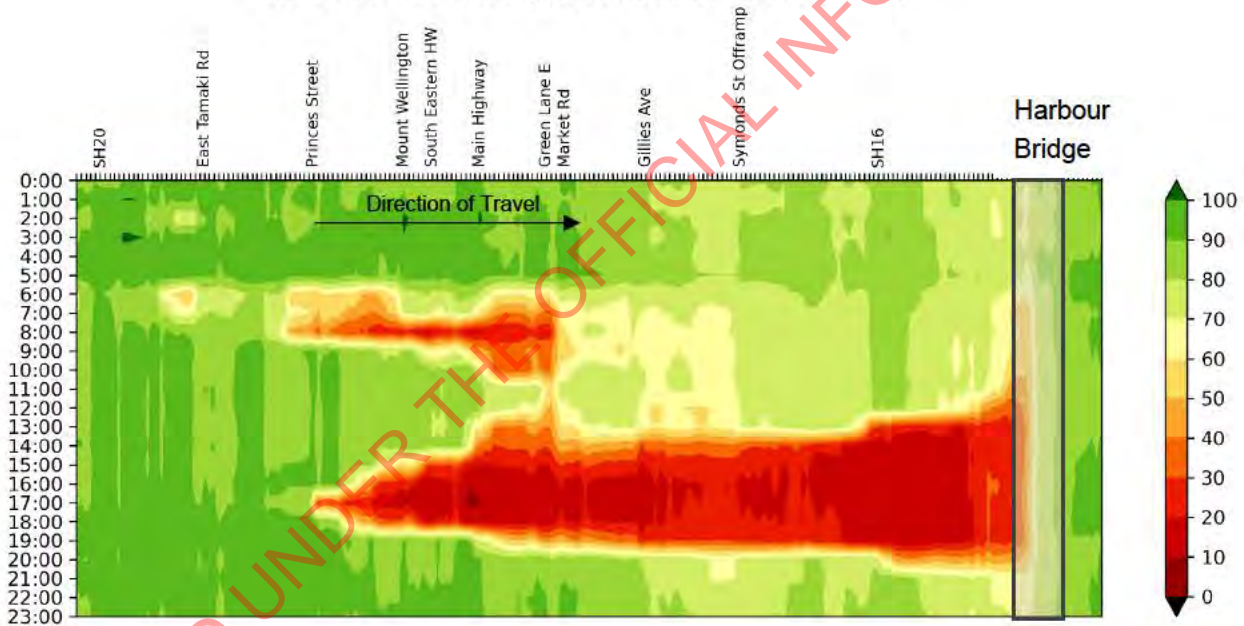

Figure 16 - Sep 2020 truck strike incident SH1 southbound traffic impacts compared the equivalent day in the week prior to the incident

Figure 17 compares the network-wide motorway traffic data from the period of reduced lane operation following the truck strike to the weeks following re-opening of all lanes in a way that allows a broad indication of the effect of reduced lanes on the AHB to be surmised, taking into account the net effect of both the capacity loss and the demand reduction (however the number of data points is low and so this needs to be interpreted with caution). At typical levels of daily customer delay hours post-incident, during the incident the motorway network as a whole could only handle 10-15% less daily demand at 4 available AHB lanes; and 4-5% less daily demand at 6 available AHB lanes. This underlines the critical nature of the AHB as a strategic link within the Auckland motorway network (for comparison the opening of the Waterview Tunnel provided an increase of around 5% of the network supply curve - the same as the loss of two lanes on the AHB).

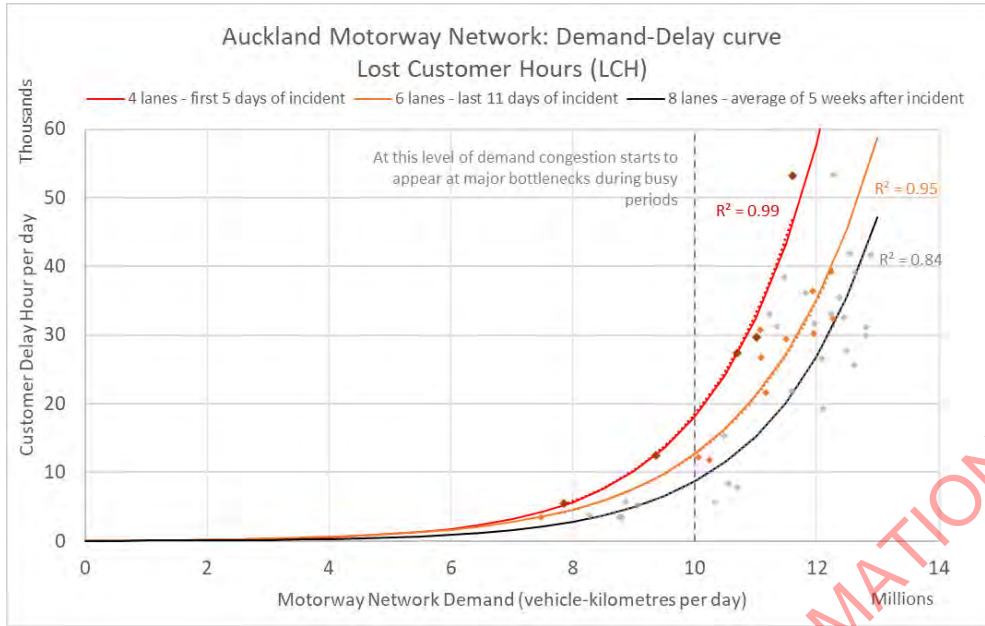

Figure 17 – Effect of lane closures in response to Sept-20 bridge strike on motorway network capacity

Unfortunately, apart from this broad-brush assessment, little further insight can be gained from the period of the incident given the apples-and-oranges nature of the comparison to pre-COVID AHB and overall motorway network demands. It is therefore necessary to look at what additional insight can be gained from predictive traffic modelling tools.

RELEASED UNDER THE OFFICIAL INFORMATION ACT 1982

6 TOOLS TO PREDICT TRAFFIC IMPACTS...AND THEIR LIMITATIONS

“All models are wrong, but some models are useful.”

The statistician George Box is known for this aphorism – and he goes on to say that the question you should ask is not “is the model true?”, but “is the model good enough to be helpful for a particular application?”

There are a number of available traffic modelling tools that can help to answer the question of what will happen to the traffic represented by the red areas in the graphs of Figure 7 and Figure 8 if one or two traffic lanes on the AHB were re-purposed as a cycling and walking facility. However, none of these tools are ideally suited to the job, and none on their own can give a fully robust answer. However, they all provide some help in trying to understand the likely impacts on traffic.

The available modelling tools are:

- Auckland Macro Strategic Model (MSM)
- Auckland Dynamic Traffic Assignment Model (ADTA)
- Northern Corridor Improvements (NCI) SATURN model
- Auckland Motorway Network Cell Transmission Model (CTM)
- AHB Queuing model (AHB-Q)

The Auckland Macro Strategic Model (MSM) covers the region’s entire road network and Public Transport system. It is operated by the Auckland Forecasting Centre and its primary role is to understand how major changes to the transport system affect mode choice between private vehicles and public transport, and how private vehicles distribute themselves across the road network. The model evaluates the network in 2-hour blocks of time (there are three 2-hour blocks to cover AM peak, interpeak and PM peak). The representation of the motorway network is coarse, and congestion is represented through delays on individual links and intersections, which is suited to large models used for strategic planning purposes. However, this type of model is not well suited to replicating small-scale operational changes because it does not provide realistic propagation of congestion and queues in a way that realistically affects performance of upstream sections of the network.

Northern Corridor Improvements (NCI) SATURN (Simulation and Assignment of Traffic to Urban Road Networks) model. The primary role of this tool is to determine how a fixed amount of traffic routes itself from a series of journey start locations (origins) to series of corresponding end locations (destinations), accounting for delays along the way. In other words, it determines how traffic is distributed across a congested network. By accounting for capacity constraints of a network (primarily at intersections) SATURN incorporates “flow metering” which provides a realistic spread of congestion across a network – including how queues can block flows at upstream intersections. SATURN is normally used to model large areas (thousands of links), although it is capable of analysing the effects of relatively minor network changes. However, it is limited in relation to analysing motorway operation in two ways:

- It was not originally designed to model motorways and as such is limited in how motorway capacity can be represented. Additionally, most effort to calibrate a SATURN model is devoted to operation of intersections on the arterial network (which usually govern the routing of traffic), often leading to the use of “typical” capacities across most motorway links, where in reality individual links may differ considerably from this.
- SATURN is normally used to model the peak hour as a single one-hour block of time, which limits the ability to accurately reflect the growth of congestion spatially across the network. The buildup of queues throughout the peak can be approximated through use of an additional 1-hour “pre-peak” model – which effectively “loads” the network with queues before the peak model is run.

The NCI SATURN model has the added limitation that it only covers the Auckland network north of CMJ and the Waterview Tunnel – SH20 and the Southern Motorway are not included. This means any congestion impacts of modifying the lanes on the AHB on the operation of the southern motorway will not be represented.

The Auckland Dynamic Traffic Assignment Model (ADTA) is also operated by the Auckland Forecasting Centre. Dynamic Traffic Assignment models also determine the routing of traffic through and its resulting distribution across a network, but they consider the growth and spreading of congestion over time and space

in a more realistic way, using multiple, smaller time periods. However, because of this Dynamic Traffic Assignment Models are extremely complex models - which is compounded when they are used to represent very large networks (the ADTA, like the MSM, covers the entire of Auckland's road network). They are very difficult to calibrate to observed data, which means that not all parts of large models will respond realistically.

The Auckland Motorway Cell Transmission Model (CTM). This tool was designed and built by the AMA Network Performance Team specifically for analysing congested operation of the Auckland motorway network and is now operated by the ASM. The CTM simulates macroscopic traffic behavior on a corridor network by dividing it into short, homogeneous sections (called cells) and calculating traffic behavior in each cell at each discrete time-step using concepts from theories of fluid flow. It has the following strengths:

- It accurately captures the formation, spreading and clearing of congestion in time and space and models an entire 24-hour period in one continuous model, using incremental 10-second time steps.
- It is simple and quick to set up and run compared to traditional models (micro, meso or macro).
- It is easy and quick to run large numbers of scenarios to sensitivity test input assumptions.
- It has been calibrated for all parts of the motorway network and validated against 2018 observed data. It is easy to incrementally improve calibration against continuously collected loop detector data.
- It realistically models the traffic responsive and coordinated operation of ramp signals, including realistic growth of queues waiting at on ramps. The ramp signals within the model have used configuration data from the SCATS Ramp Metering System implemented in Auckland achieve realistic operation.

There are two primary weaknesses of the CTM:

- it only simulates the traffic impact of a given, fixed demand pattern – it does not re-route traffic when congestion delays get high. However, it is quick and easy to incrementally modify demand patterns manually and run multiple scenarios quickly.
- It only covers the motorway network and does not include arterial or local roads and therefore cannot directly simulate the impact on them of changes to the motorway network or its operation. However, through the operation of ramp signals in the model changes in on ramp queues can be used to infer likely impacts on the arterial and local road network. This is limited by the fact that the impact on through traffic on adjoining arterials getting caught up in ramp signal queues that block back onto these routes is not captured. Nevertheless, changes in queuing at the on-ramp, corridor and network level between modelled options is still a useful proxy for relative arterial impacts.

AHB Queuing model (AHB-Q). This simple spreadsheet-based queuing model was built by the ASM following the truck strike of the AHB in September 2020, to allow the impact of alternative MLB operations on traffic flows in both direction over the bridge to be assessed rapidly. By using accurate, detailed arrival profiles for the foot of the bridge in each direction under a range of daily demand levels, combined with accurate capacities for each lane configuration, a clear picture of the growth and dissipation of backlogged traffic in either direction can be attained. However, it does not track the progression of queues spatially along the adjoining corridor and cannot account for the interaction of queues with upstream congestion, on / off ramps or adjoining arterials.

Figure 18 provides an overview of the relative strengths and weaknesses of each of these modelling tools. The tools were used in the following ways in the assessment of the options:

- The AMN-CTM was used as the primary tool for evaluating the impact on motorway traffic congestion. The capacity of the options was represented as accurately as possible from the preliminary layout designs available at the time of the assessment. Multiple demand scenarios were tested, with changes in demands comprising the following components.
 - Targeted mode shift (removal of traffic between specific on and off ramps)
 - Re-routing (manual reassignment of traffic away from AHB to SH16/SH18/SH20)
- The MSM was used to guide the magnitude of targeted mode shift to PT. We engaged with AFC who ran several AHB lane reduction scenarios to represent the range of options.

- The MSM and NCI SATURN model were used to guide the magnitude of re-routing and the broad entry and exit locations of these trips to/from the motorway. In addition to engaging with AFC, we discussed the NCI SATURN model with Flow Transportation Specialists and conducted several tests with the model.
- The AHB-Q was used as a “common sense” check on the duration of congestion generated in the AMN-CTM at the foot of the bridge in each direction for different options, and to a lesser extent the spatial extent of the resulting congestion.
- It was intended to use ADTA to better understand the potential propagation of congestion onto arterial and local road networks. However, the timeframe was too short for us to agree with AFC what tests to run and for them to prepare and run them in time for inclusion in this report.

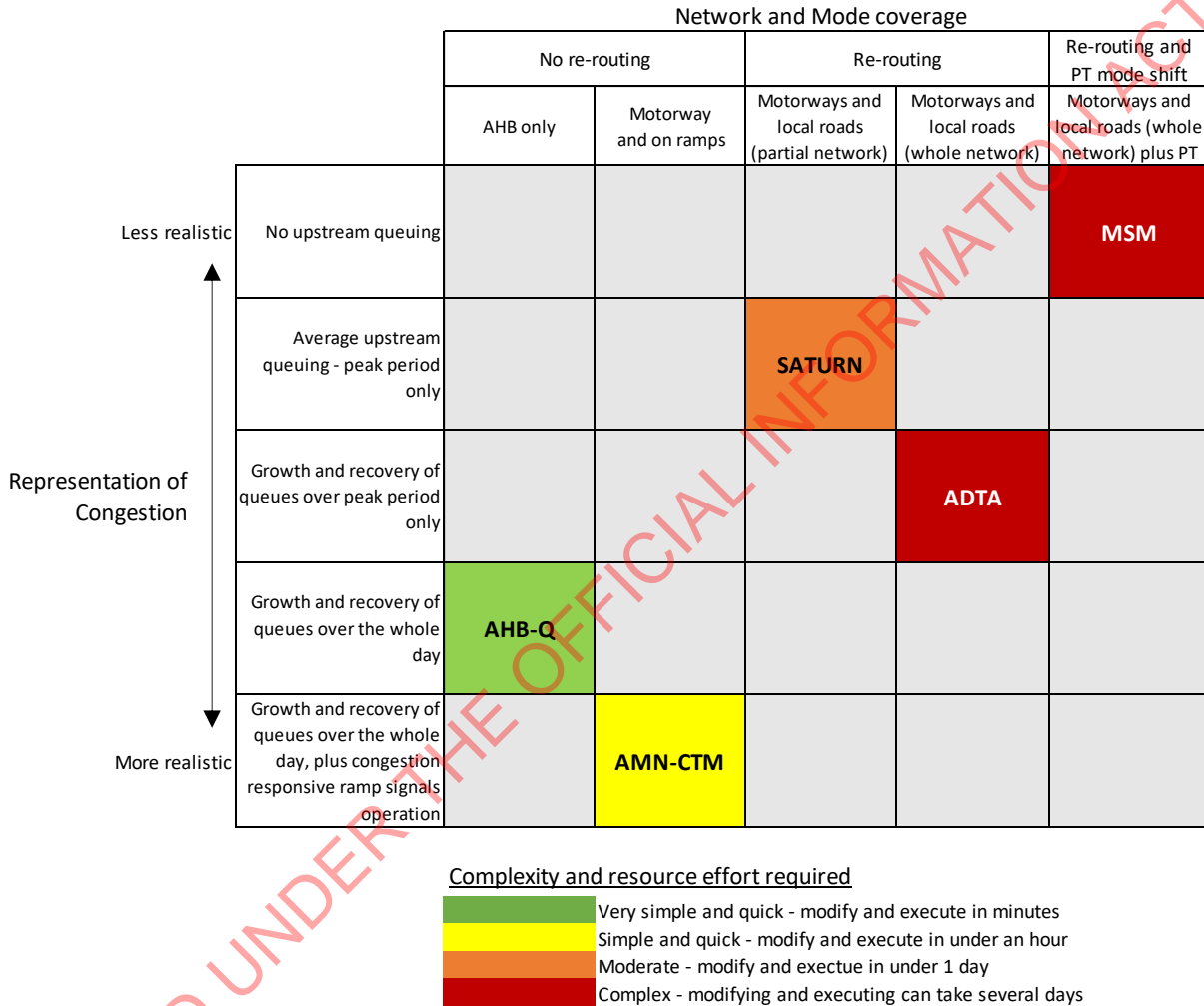

Figure 18 – Summary of strengths and weaknesses of relevant traffic modelling tools available

7 EFFECTS ON TRAFFIC DEMAND

7.1 Mode shift to active modes

Previous work on cross-harbour walking and cycling has established an expected 2026 demand of around 1,600 daily pedestrian and cyclist commuter trips, increasing to 2,300 by 2046³. AFC have indicated that the Active Mode model provided an estimate of around 2,000 cycling trips and 500 walking trips per day. A successful reallocation of a traffic lane on the Burrard Bridge in Vancouver initially attracted an average of 1,000 trips per day in its first year (2009) which rose to 3,300 by 2017⁴.

The following levels of pedestrian and cyclist demand have been adopted for the CTM analysis:

- Low – 1,000 trips per day (both directions, evenly split)
- Medium – 2,000 trips per day (both directions, evenly split)
- High – 3,000 trips per day (both directions, evenly split)

However not all active mode use of the new facility will remove traffic demand from the bridge. Some of these trips will shift from PT and some may be newly generated trips (many of these at weekends for recreational reasons). For the purposes of this assessment, it has been assumed that all active mode trips using the bridge will be to/from locations in or close to the CBD. As a result the proportion of active mode trips shifting from PT (as opposed to private vehicle) has been assumed to be 50% on weekdays during peaks - based on AT patronage data (assuming all PT trips are similarly to/from locations in or close to the CBD) and the proportions of vehicles using the bridge headed to/from the CBD.

7.2 Mode shift to PT

Patronage on buses that cross the AHB remains down 20% (daily) and 27% (peak hour) on pre-COVID levels (comparing March 2021 to March 2019). This means there is currently significant spare capacity for bus services across the bridge to absorb potential mode-shift from private vehicle trips. However, the lower patronage is likely related to continued concern over COVID, the inconvenience of the requirement to wear masks on PT and a residual increase in working from home. Completion of the vaccine rollout may help address these issues; particularly once younger age cohorts have received the vaccine. This may mean return to pre-COVID patronage levels is possible by early 2022 – but this is by no means certain.

Review of flow difference plots from the MSM model indicates the mode shift to PT for trips across the AHB.

Table 2 – MSM tests – number vehicles removed from AHB due to mode shift

(vehicles/hr)	7-lane options	6-lane options
AM peak	55-65	850-900
PM peak	300-550	1,600-1,700

The discrepancy between AM and PM peaks seems a little counterintuitive as most PT trip one -way across the harbour are likely to undertake a return trip on the same day.

³ *Cross-harbour Walking & Cycling – Transport Modelling and Economic Benefit Evaluation, Flow Transportation Specialists (December 2018).*

⁴ <https://vancouver.sun.com/news/local-news/ten-years-of-bike-lanes-in-vancouver-life-goes-on-chaos-averted>.

7.3 Trip Re-routing and Re-timing

The potential re-routing options for private vehicle trips across the bridge are limited to use of SH18 by way of the Upper Harbour Bridge and SH16. SH16 ramps at CMJ provide alternative access to/from the CBD and links to SH1 (southern) via CMJ and SH20 via Waterview Tunnel provide motorway connectivity for trips to/from further south.

Table 3 summarises the re-routing via this route indicated by the MSM and NCI SATURN models.

Table 3 – MSM and SATURN re-routing indicated via Upper Harbour Bridge (SH18)

(vehicles/hr)	7-lane options		6-lane options
	MSM	NCI SATURN	MSM
AM peak (SB)	<100	200	250-300
PM peak (NB)	100-200	800	600-650

Both the MSM and NCI SATURN model predict some re-routing of traffic to these routes under testing of reducing AHB capacity by one lane. However, the re-routing determined by the NCI SATURN model with 7-lanes remaining on the AHB is as high as the MSM scenarios with only 6 lanes on the bridge. Flow difference plots for each model were reviewed to investigate the difference. In the NCI SATURN model, many of the reassigning trips use the full length of SH18 and SH16 as an alternative to SH1 to travel between the CBD or CMJ and the north shore. However severe capacity constraints on SH16 citybound in the AM and outbound in the PM mean this corridor is currently congested for almost its entire length when these trips would be using the corridor (with average travel speeds around 30 km/hr).

7.4 AHB traffic demand reductions assumed in the assessment

Using the information in sections 7.1 to 7.3 four weekday and four Sunday AHB traffic demand reduction scenarios were developed for use in the CTM assessments (see Table 4 and Table 5).

Table 4 – Demand change levels used for AHB traffic reduction (weekdays)

AHB weekday demand change		Daily	Peak hr
Level 1	cyclists + pedestrians (people)	1,000	42
	PT mode shift (people)	2,000	285
	Re-routing (vehicles)	0	0
Level 2	cyclists + pedestrians (people)	2,000	111
	PT mode shift (people)	4,000	450
	Re-routing (vehicles)	970	166
Level 3	cyclists + pedestrians (people)	3,000	125
	PT mode shift (people)	7,000	1,000
	Re-routing (vehicles)	1,900	330
Level 4	cyclists + pedestrians (people)	3,000	125
	PT mode shift (people)	11,000	1,600
	Re-routing (vehicles)	4,850	650

Table 5 - Demand change levels used for AHB traffic reduction (Sundays)

AHB Sunday demand change		Daily	Peak hr
Level 1	cyclists + pedestrians (people)	3,000	400
	PT mode shift (people)	700	110
	Re-routing (vehicles)	2,300	350
Level 2	cyclists + pedestrians (people)	3,000	400
	PT mode shift (people)	700	110
	Re-routing (vehicles)	2,900	430
Level 3	cyclists + pedestrians (people)	3,000	80
	PT mode shift (people)	700	110
	Re-routing (vehicles)	3,500	540
Level 4	cyclists + pedestrians (people)	3,000	400
	PT mode shift (people)	700	110
	Re-routing (vehicles)	4,000	625

Note that in each case it was assumed a proportion of active mode trips were new trips (rather than transfers from other modes, intended to represent recreational trips) and a proportion of active mode trips were assumed to be transfers from PT (rather than private vehicle trips). The remainder were assumed to be transfers from private vehicles:

- Weekdays – active mode new trips – 0%
- Weekdays – active mode transfers from PT – 50%
- Sundays – active mode new trips – 60%
- Sundays – active mode transfers from PT – 20%

For both weekdays and Sundays, the Level 1 and 2 demand reductions were applied to produce High-Low demand estimates for 7-lane options and Level 3 and 4 demand reductions were applied to produce High-Low estimates for 6-lane options. Some varying of re-routing levels by direction were used where one direction has less peak lane capacity than the other.

Figure 19 – shows the four sets of weekday demand profiles used for the CTM assessments.

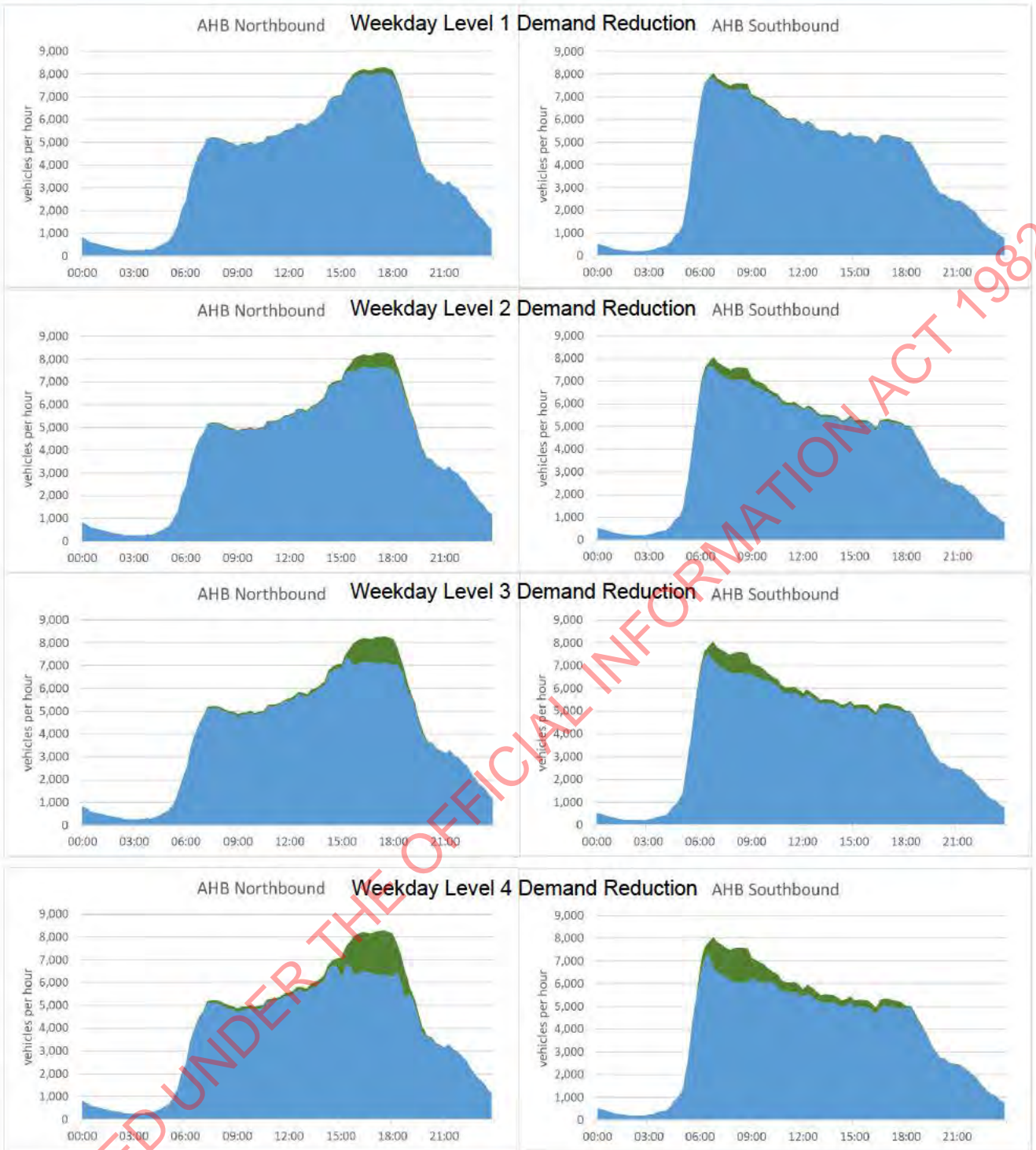

Figure 19 – Reduced AHB traffic profiles used for CTM assessments (blue). Green section indicates reduced demand

8 EFFECTS ON NETWORK AND CUSTOMER JOURNEYS

Figure 20 and Figure 21 below provide an overview of current network conditions on typical Sundays and weekdays, in terms of demand and capacity at the AHB and congestion levels and distribution on the motorway network overall (as represented by the CTM for pre-COVID conditions). This is to provide context for the results that follow in terms of network impacts for both temporary and permanent cycle lane options.

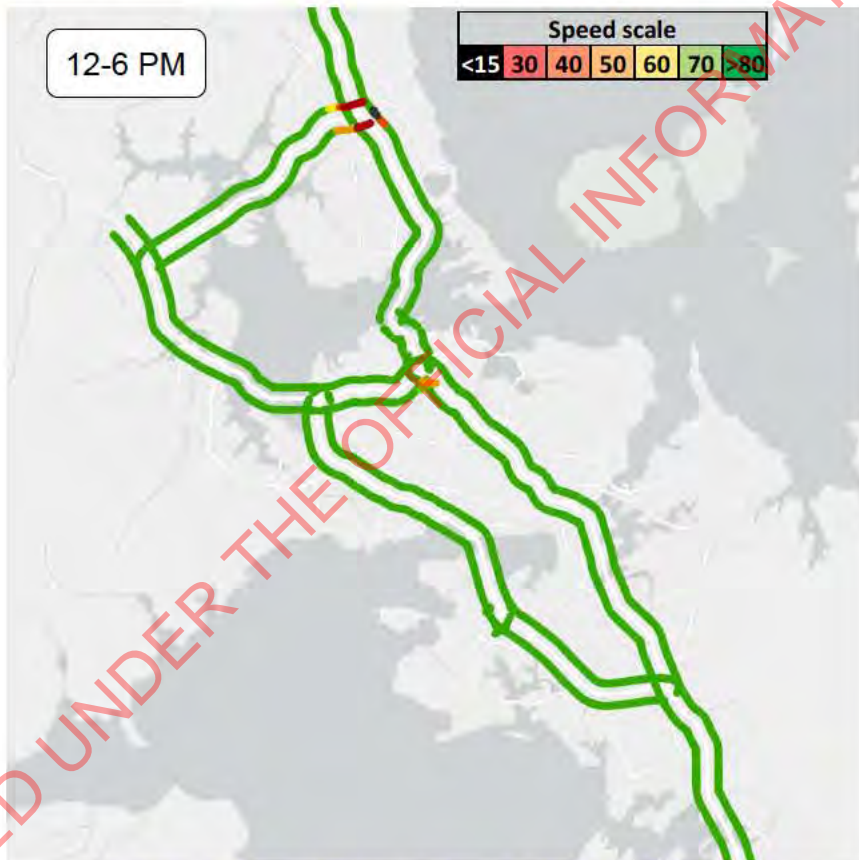
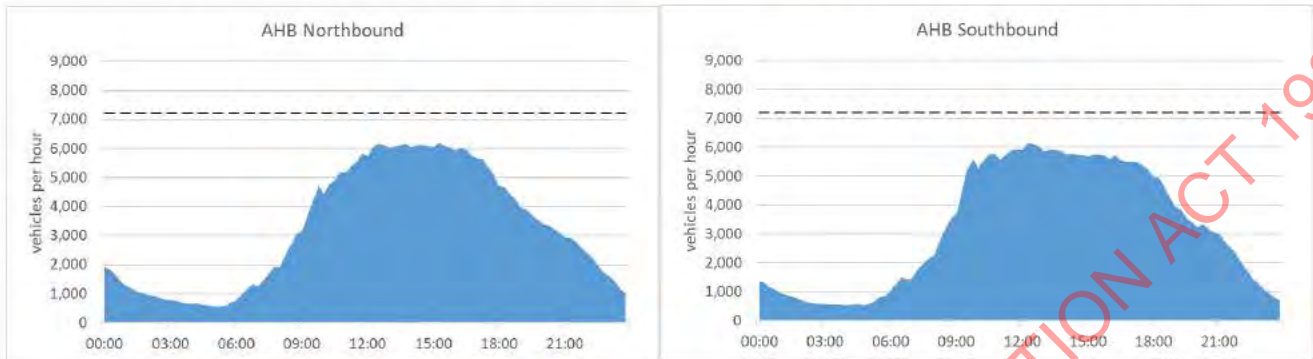

Figure 20 – Current network operating conditions - SUNDAYS

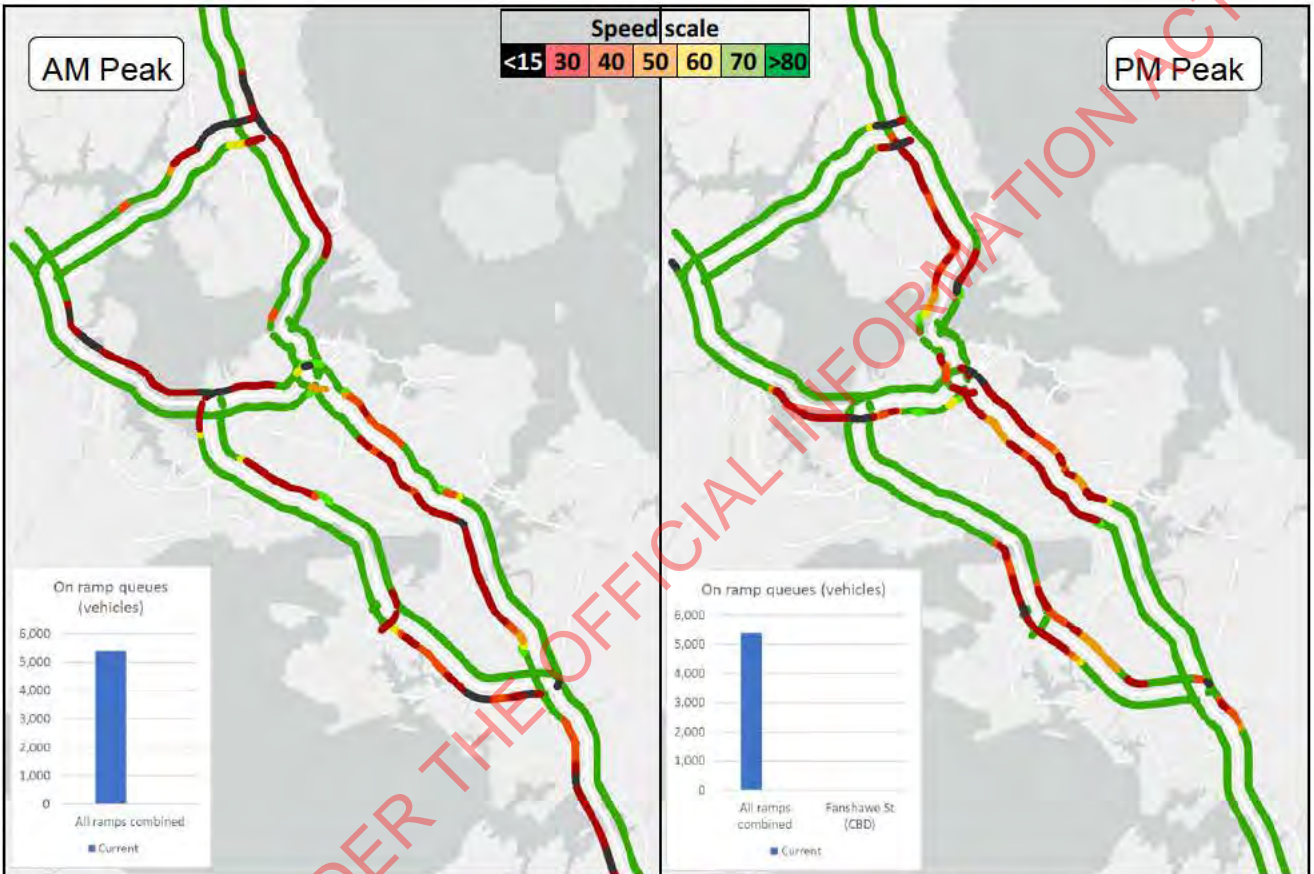
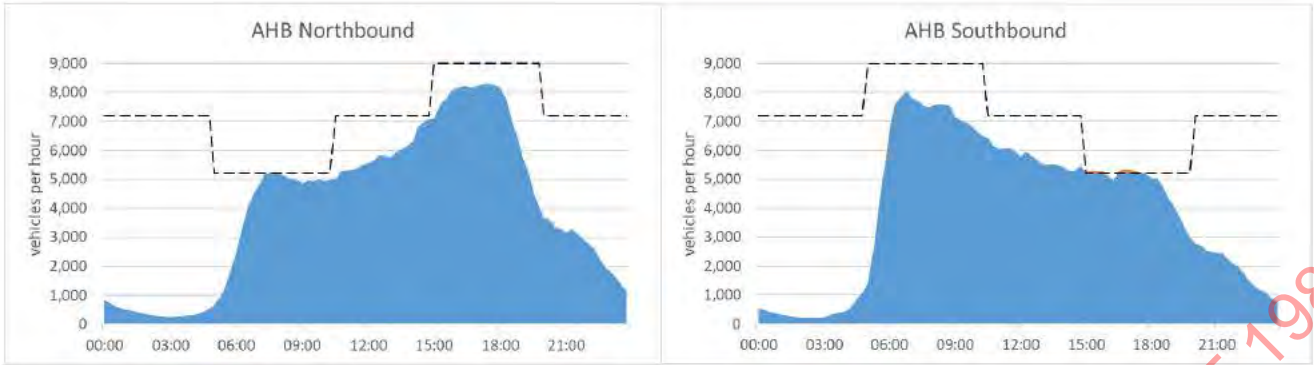

Figure 21 – Current network operating conditions – WEEKDAYS

In assessing the traffic impacts of the different active mode facility options on the operation of the overall motorway system there are three Important aspects to consider:

- Overall magnitude of congestion and delay impacts
- Distribution of congestion and delay impacts
- Resilience of the network and resulting reliability of customer journeys

These will be reviewed in turn in the following sections. Given the large amount of data generated by the assessments, the results have been prepared in a way that compresses this information as far as possible without losing relevant details. Metrics are only provided at the summary (network) level with more detailed information provided predominantly via visual plots of data, to enable easier comparisons to be made.

8.1 Note of Caution

The timeframe for carrying out this assessment was very limited, and a large number of options needed to be considered. With the AHB being such a significant strategic location, analysis is sensitive to small changes in input assumptions, in particular the assumptions around changes in traffic demand in response to increased congestion.

High	Relatively high confidence – demands used considered reasonable
Moderate	Moderate confidence – further minor revision of demand assumptions required
Low	Low confidence – significant further revision of demand assumptions required

8.2 Overall magnitude of Congestion Delay Impacts

The graph in Figure 22 provides an overview of overall network congestion and delay impacts for all options (motorway mainline and on ramp queue delays). The results have been normalised to provide an apples-with-apples comparison across options, given that overall network demands vary across options. Values for current weekdays and Sundays have also been included to provide a relevant reference each both types of option.

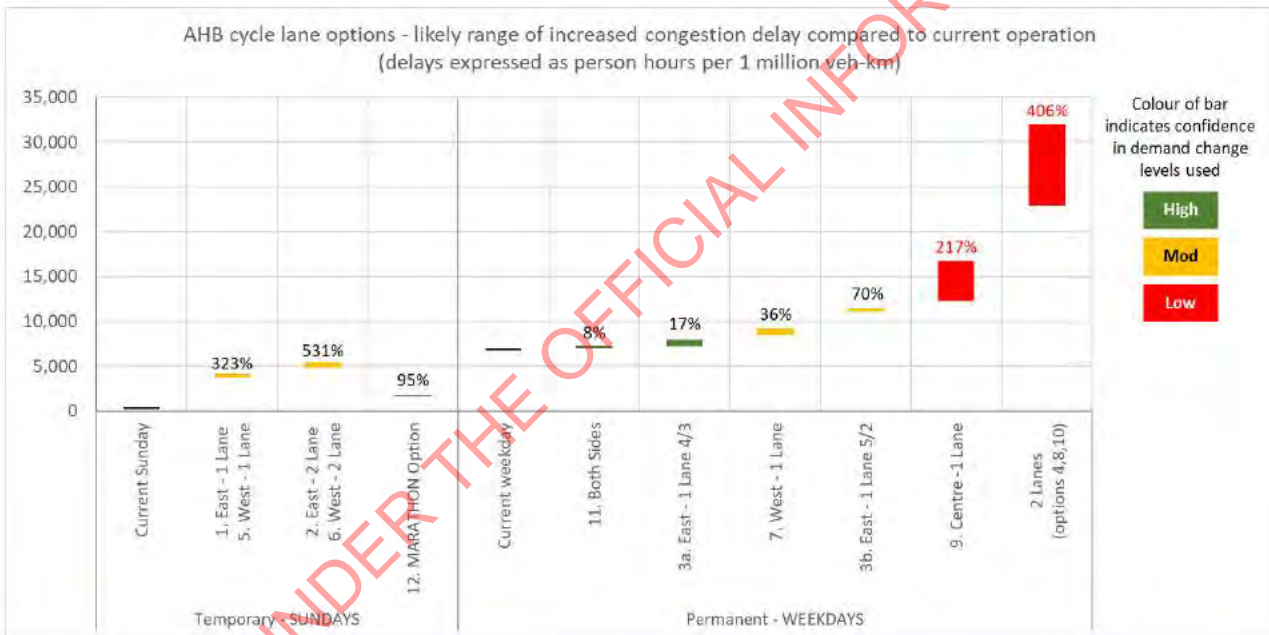

Figure 22 – Overview of overall motorway congestion impacts across all options (mainline plus on ramp delays)

Note the following salient observations:

- Confidence in demand assumptions for permanent options 9 and the 2-lane options (4,8,10) are still relatively low. Whilst the absolute magnitude of overall delay range for these options should be treated as provisional, from the analysis so far it is clear the delays for these options will be considerably larger than for the other options.
- The scale used to accommodate the results for the permanent 2-lane options make the relative differences between the other options and the current operations appear small. The percentage values indicate how much additional congestion could be expected in the worst case (low demand change) for these options compared to the current conditions.
- The only option that achieved a neutral overall impact for the high-low demand range tested was option 11 at the high demand change level used (weekday level 2 demand reduction). Although there was not sufficient time for full sensitivity testing, early tests indicate that option 3a. would require weekday level 3 demand reduction to achieve neutral impacts.

8.3 Distribution of congestion and delay impacts

A one-page summary has been prepared for each option, to provide an overview of the expected distribution of impacts across the motorway network.

Note the colour of the title bars on each page indicate the level of confidence in demand changes applied to date – red ones still need more work.

Time constraints and the need for brevity meant only one demand scenario result has been plotted for each option at this stage and is indicated in the title bar of each one-page summary. However, the distribution of impacts is broadly similar for both demand scenarios for a given option and the difference in overall magnitude of impacts are indicated in the previous section.

A key interaction evident in all of the weekday options except option 3b is the re-distribution of PM peak congestion from the northern motorway northbound to the southern motorway northbound (this is also likely to impact the CBD via queuing at Fanshawe Street and further worsening of congestion on Grafton Gully to access the link to north).

It is difficult to understand to what extent increased congestion through St Mary's Bay will lead to extensive queuing on Fanshawe Street – as detailed design of potential layouts could change parameter values used in the CTM to which the relative priority between the mainline from VPT and Fanshawe Street onramps are very sensitive.

RELEASED UNDER THE OFFICIAL INFORMATION ACT 1982

Option 1 (Option 5) – One lane for active modes on eastern (western) clip-on.
4 traffic lanes northbound, 3 lanes southbound – LEVEL 2 demand reduction

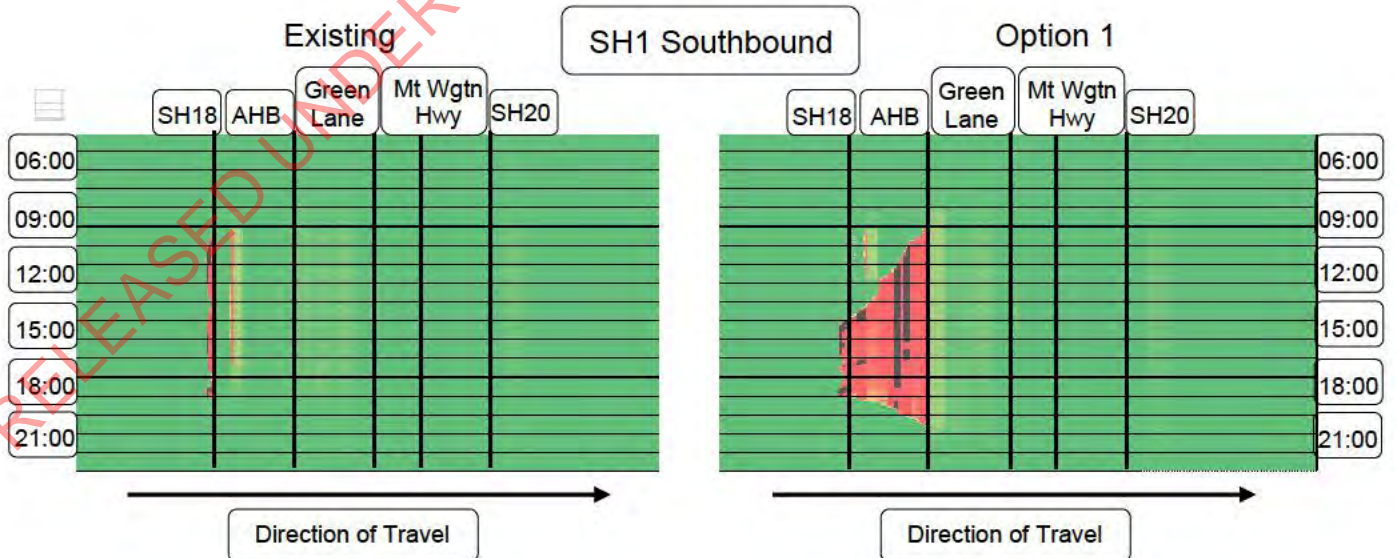
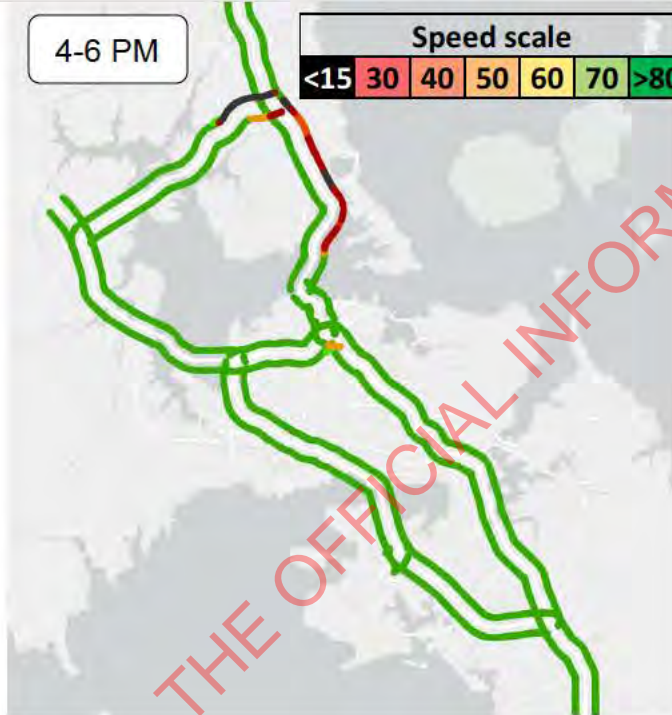
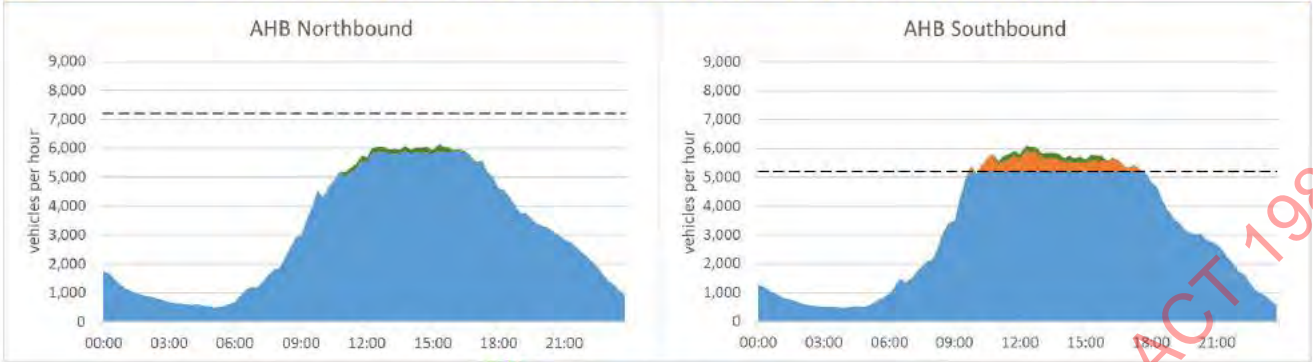

Option 2 (option 6) – Two lanes for active modes on eastern (western) clip-on.
3 traffic lanes northbound, 3 lanes southbound – LEVEL 4 demand reduction

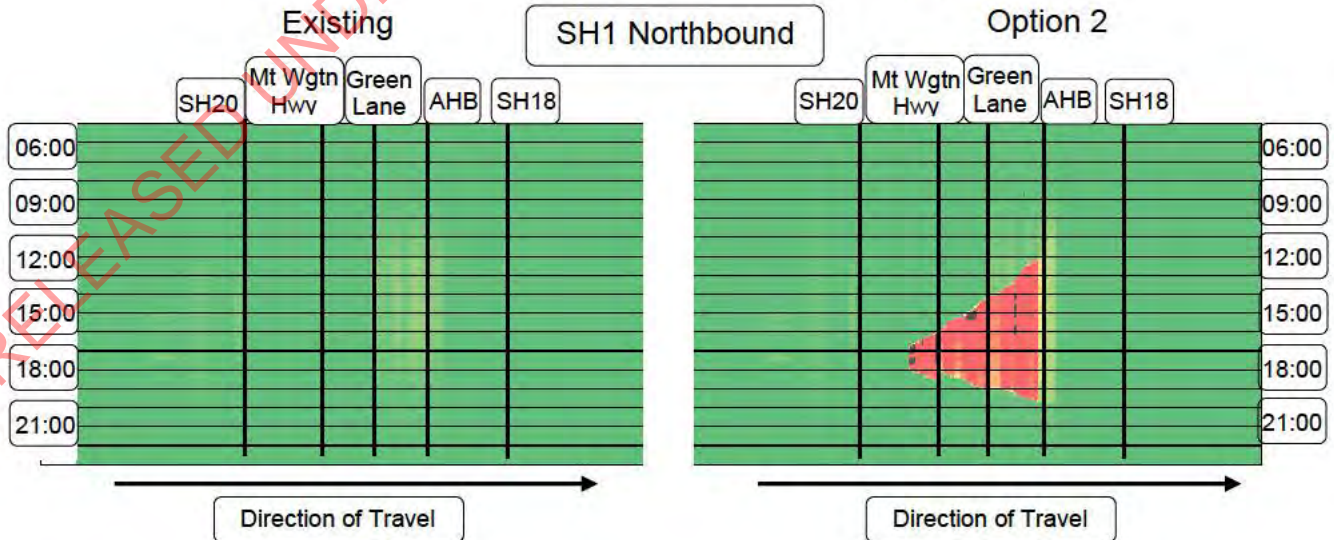
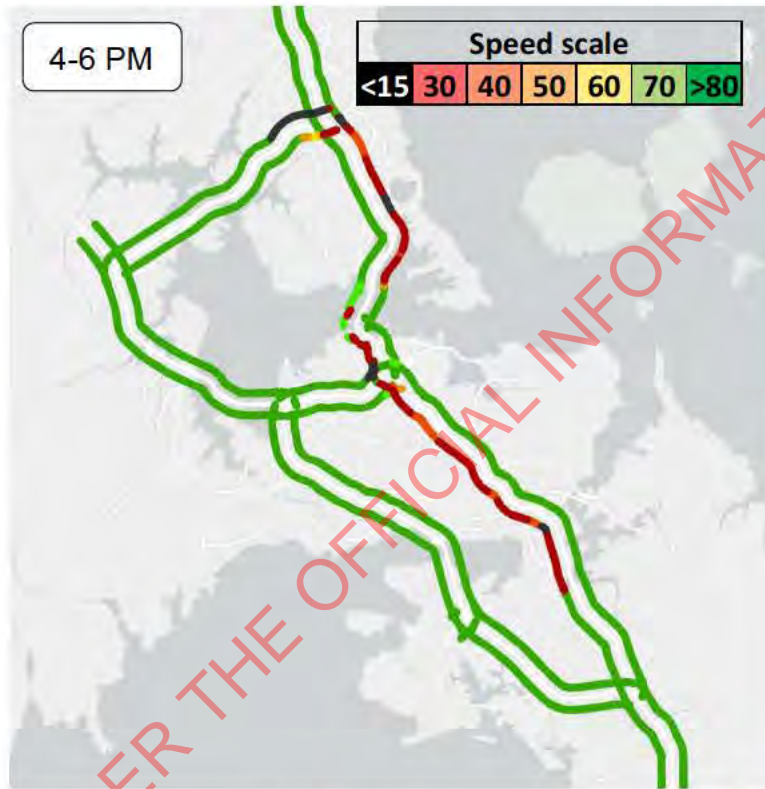
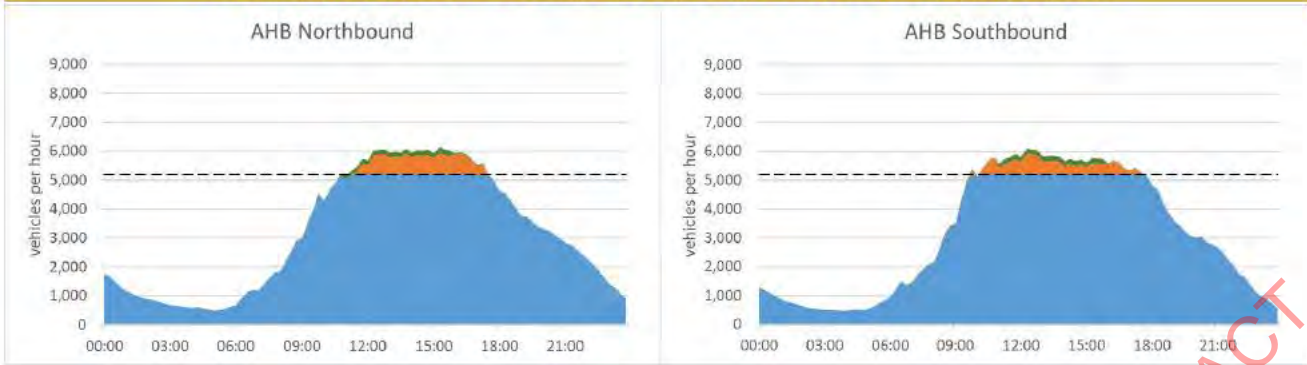

Option 12 MARATHON layout – Two lanes for active modes on eastern clip-on.
3 traffic lanes northbound, 3 lanes southbound until 1pm then 4 traffic lanes each way
LEVEL 2 – demand reduction

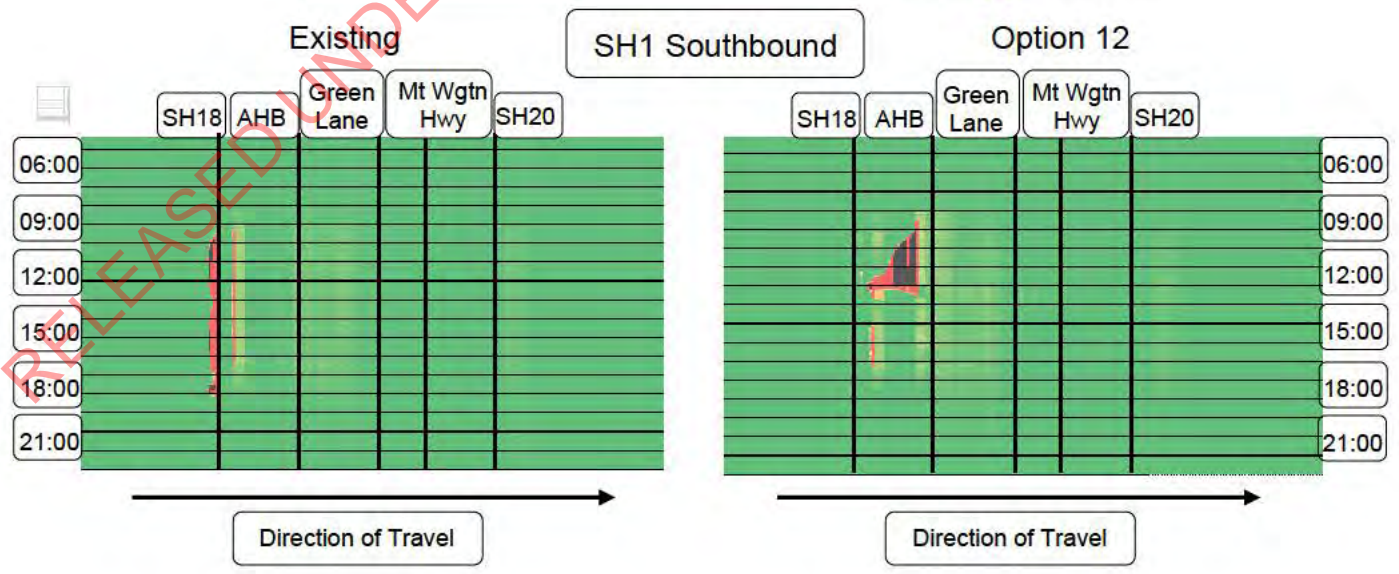
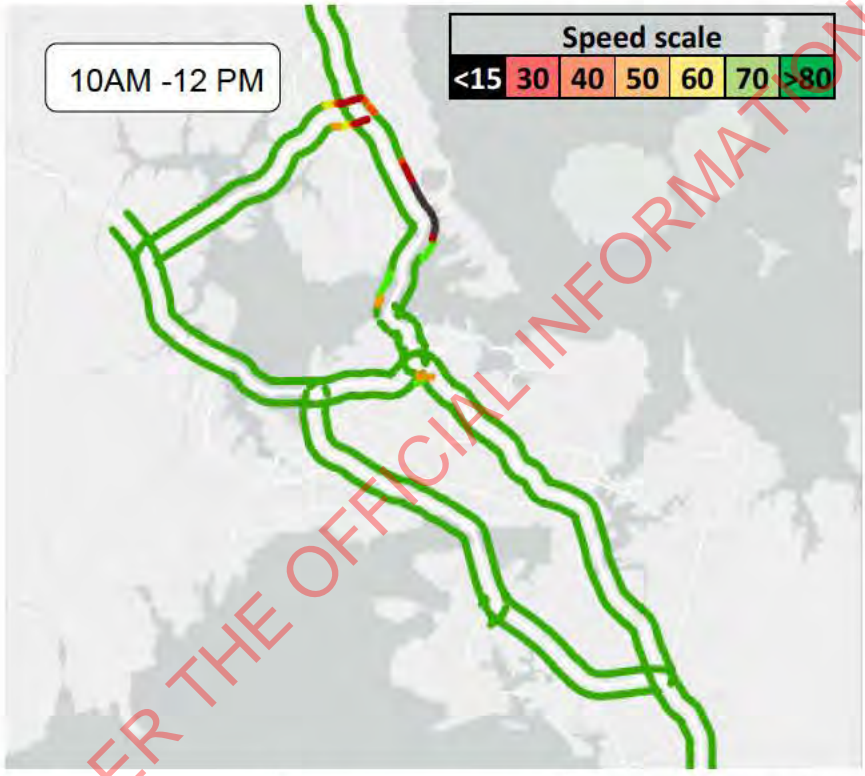
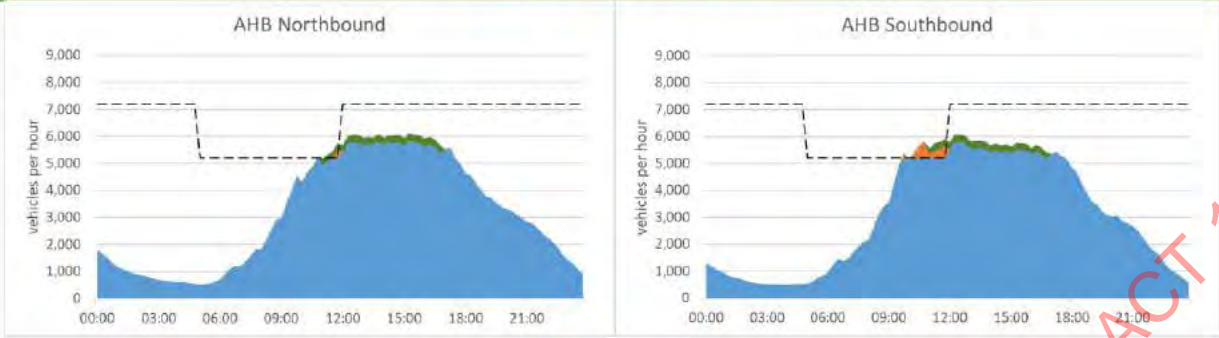

Option 3a – One lane for active modes on eastern clip-on.
4 traffic lanes in peak direction. 3 lanes in counter peak direction – LELVEL 1 demand reduction

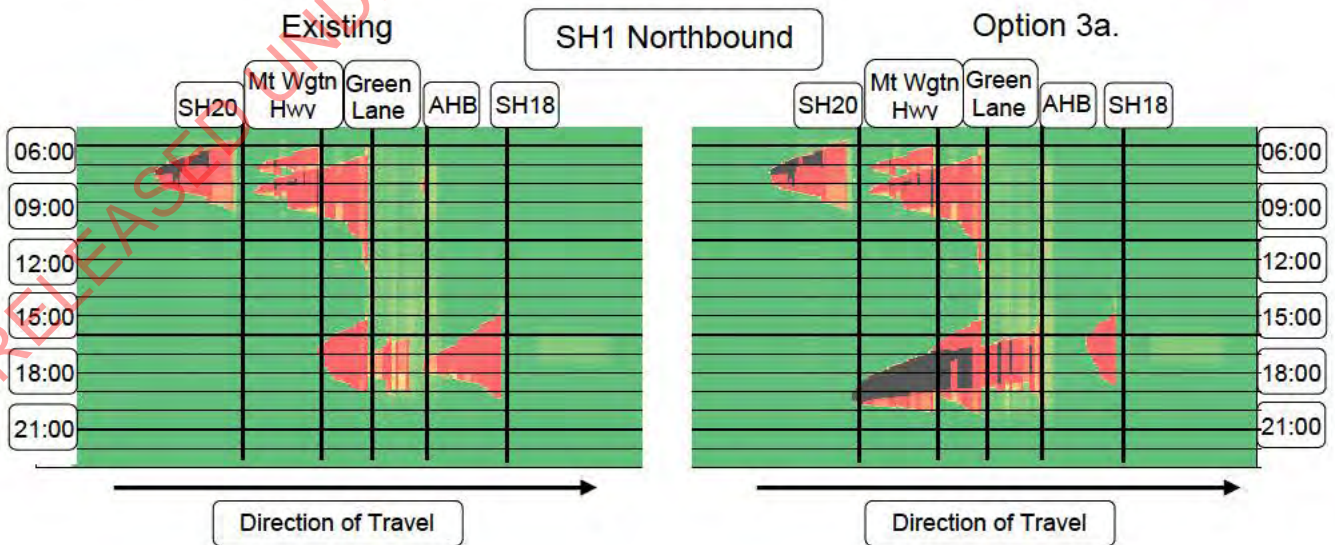
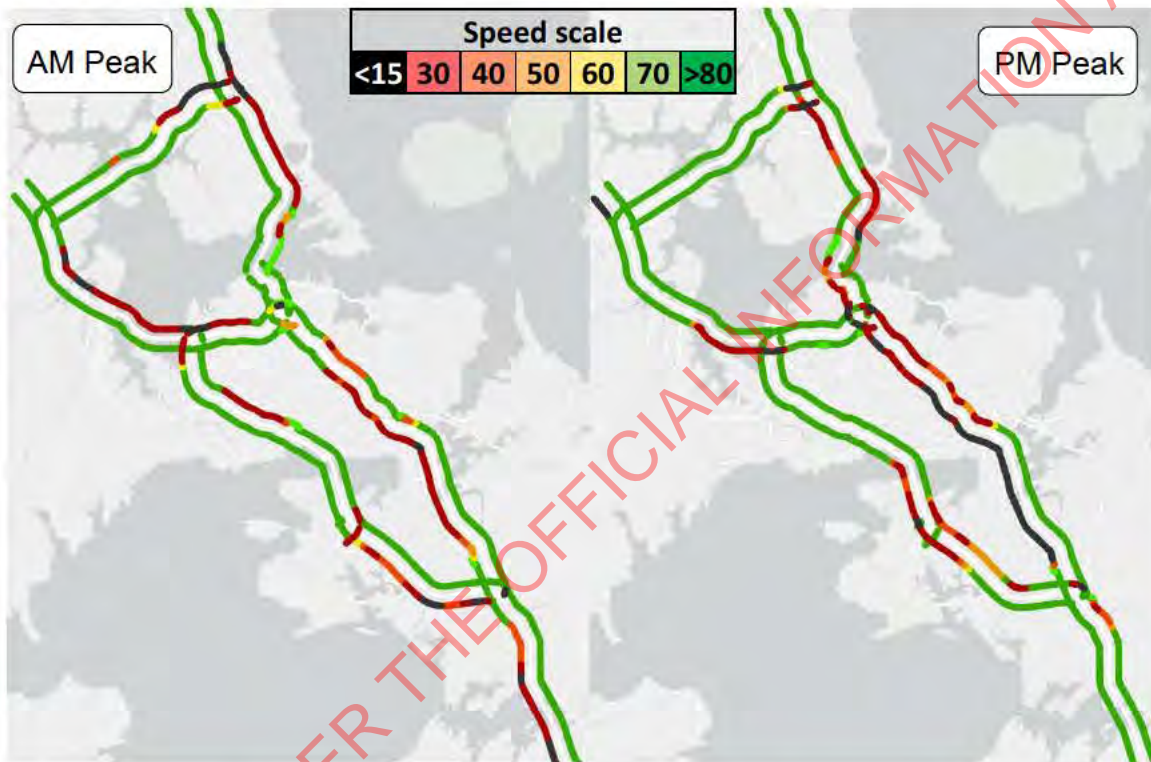
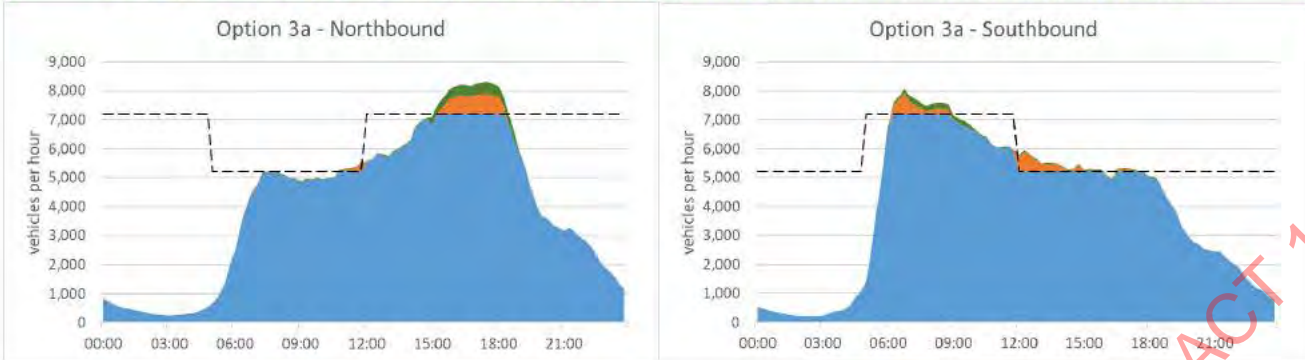

Option 3b – One lane for active modes on eastern clip-on.
AM - 4 traffic lanes SB (3 NB). PM - 5 traffic lanes NB (2 SB) – LEVEL 1 demand reduction

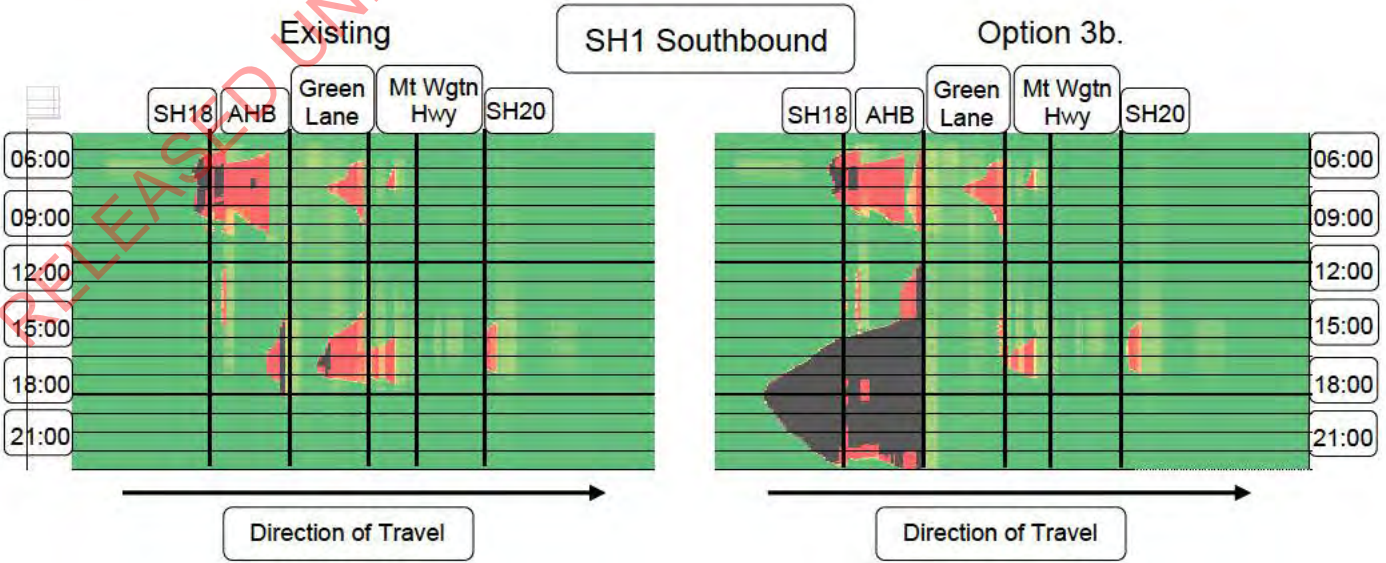
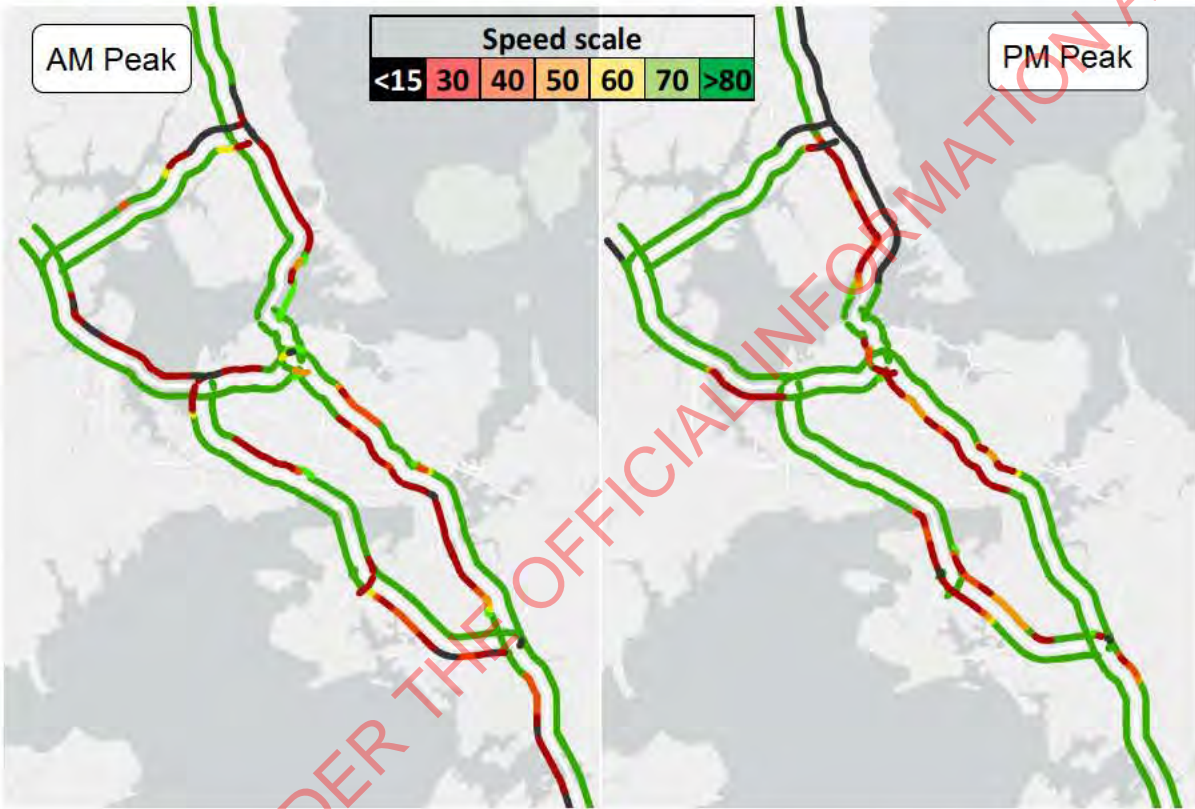
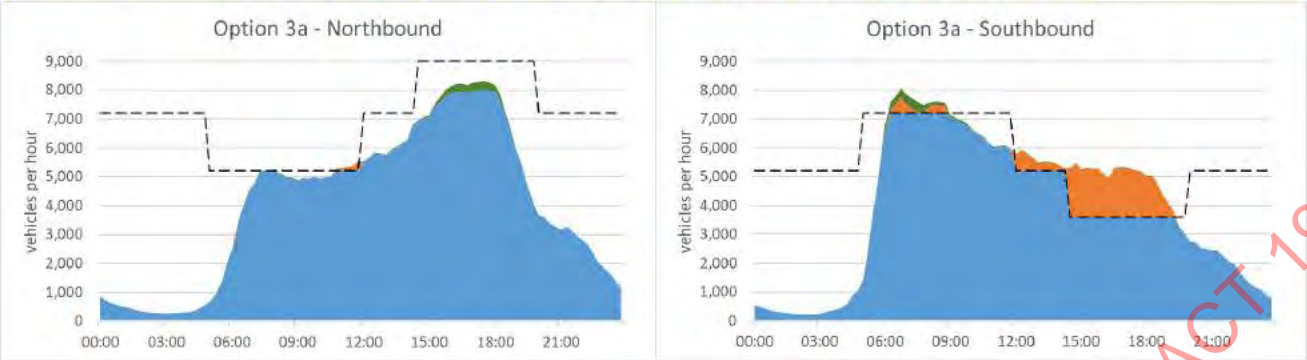

**Option 7 – One lane for active modes on western clip-on (Curran on ramp CLOSED).
4 traffic lanes in peak direction, 3 lanes in counter peak direction – LEVEL 1 demand reduction**

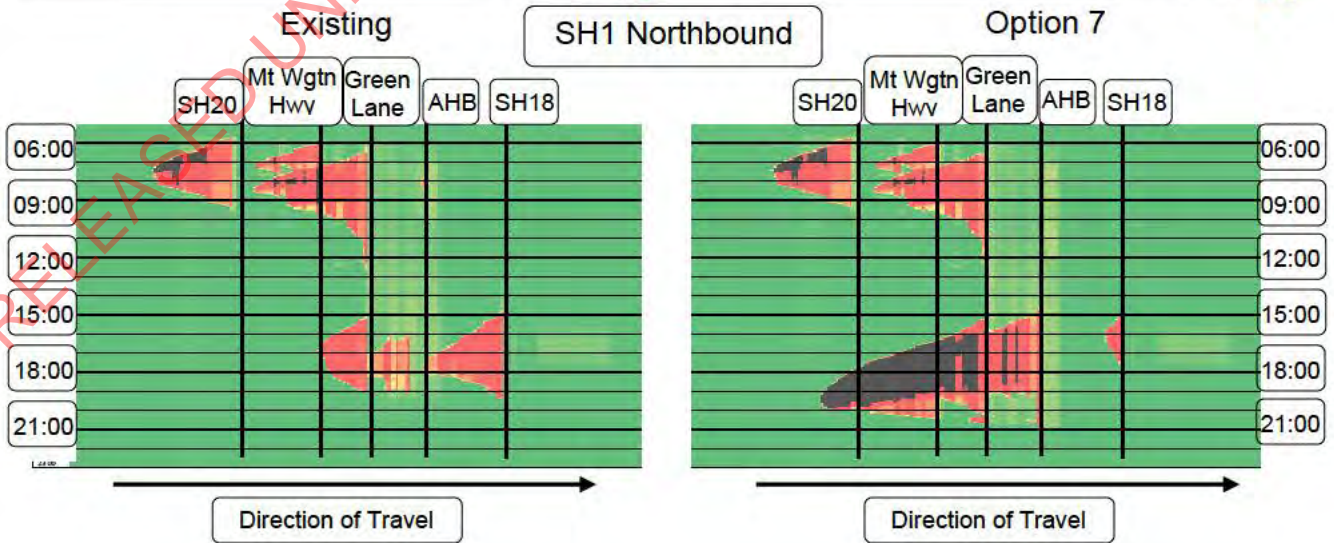
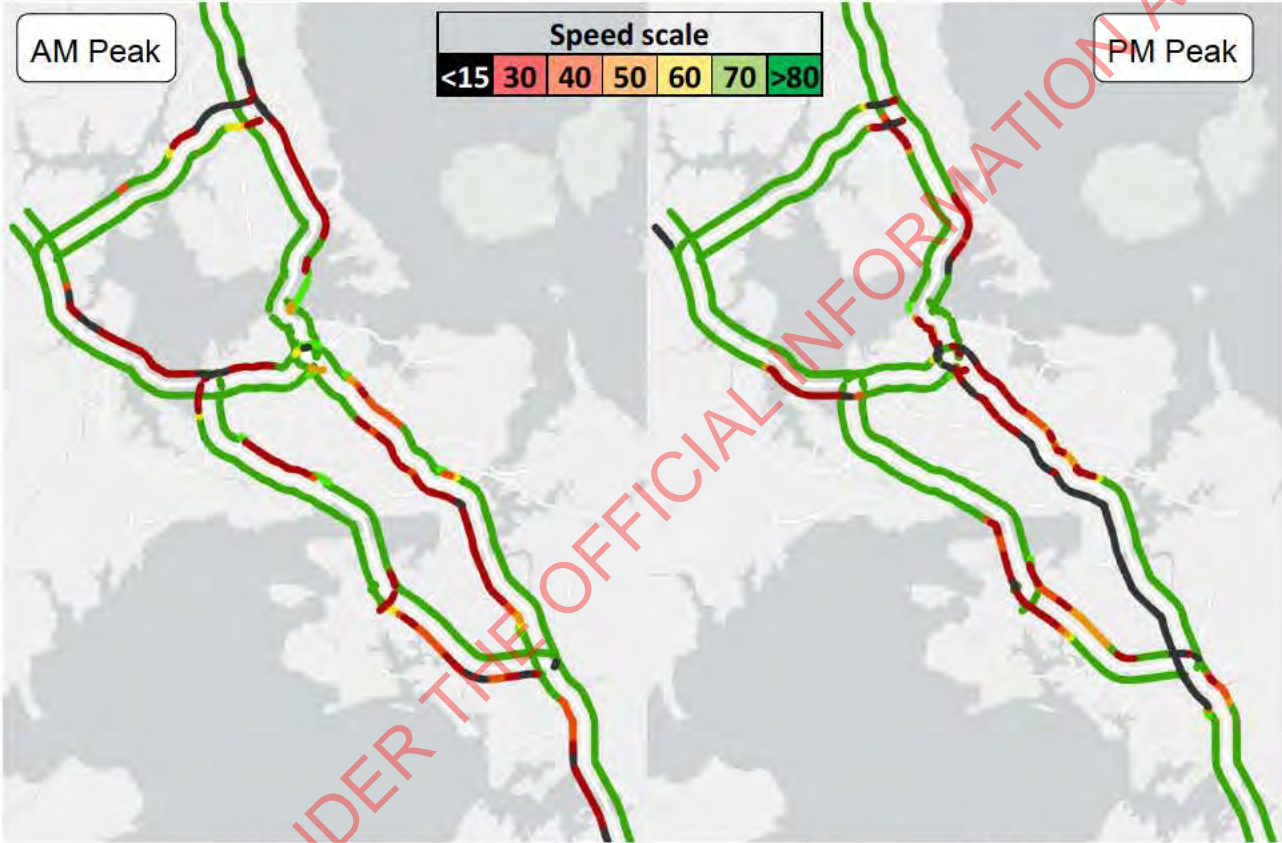
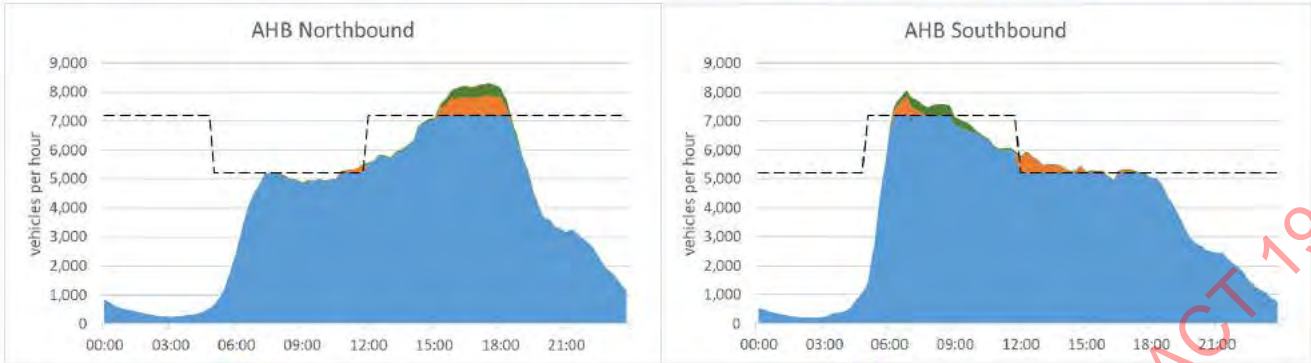

Option 9 – One lane for active modes on main truss.
4 traffic lanes NB (all day), 3 traffic lanes SB (all day) - LEVEL 4 demand reduction

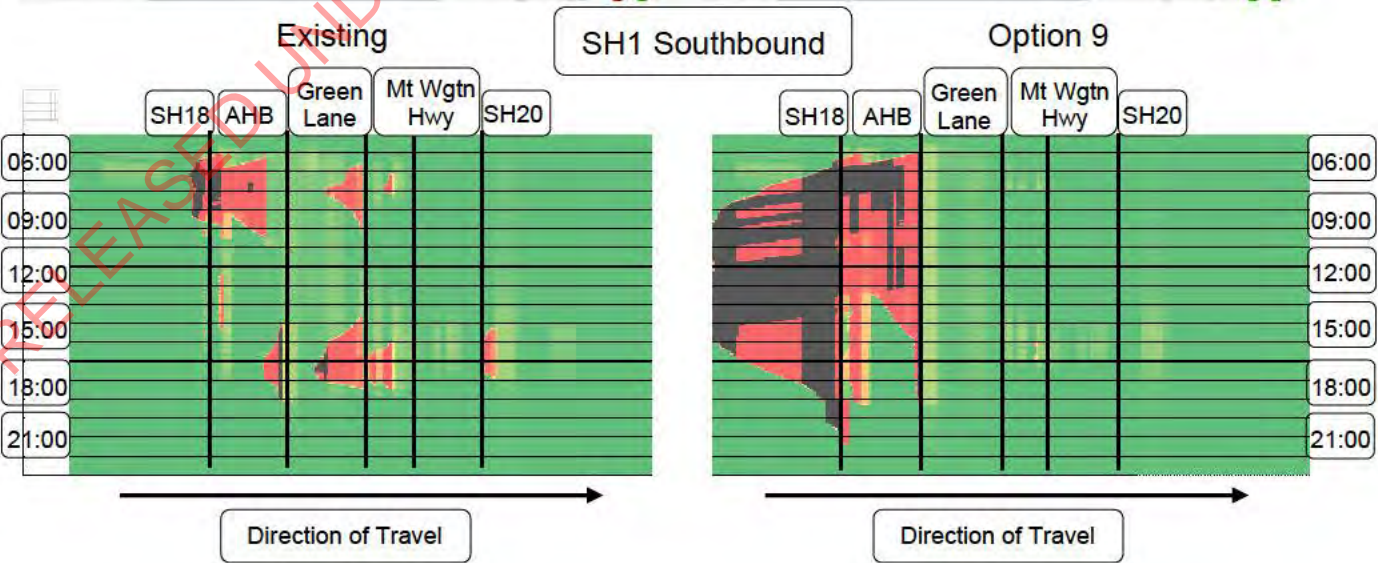
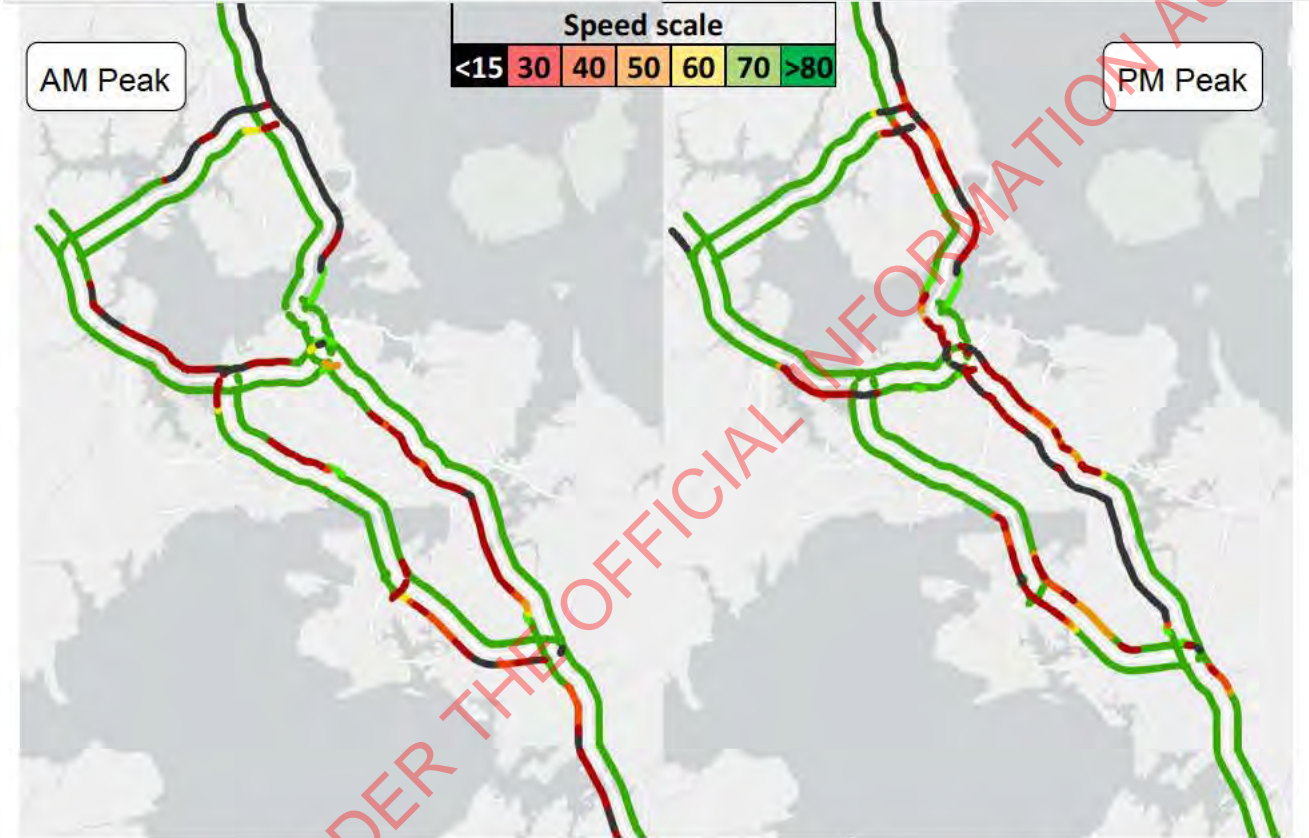
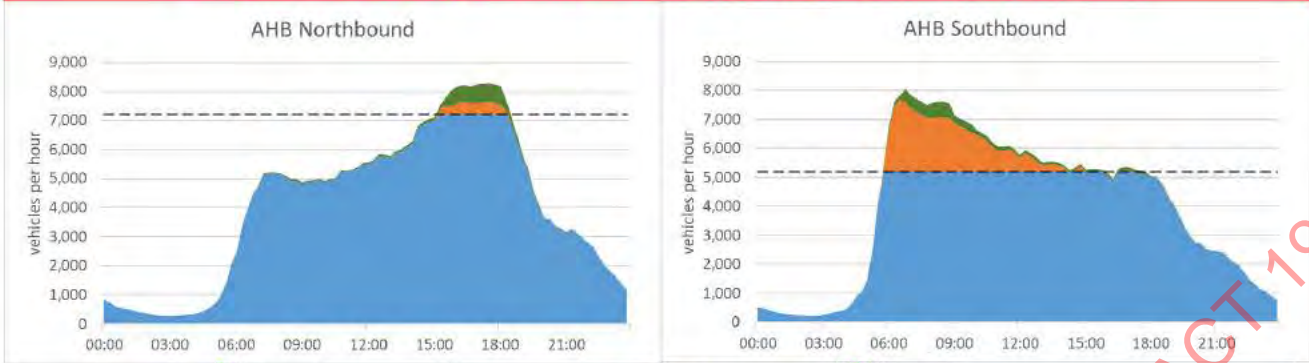

Options 4, 8 one entire clip-on for active modes (two lanes).
Option 10 - 2 lanes for active modes on main truss
3 traffic lanes NB (all day), 3 traffic lanes SB (all day) – LEVEL 4 demand reduction

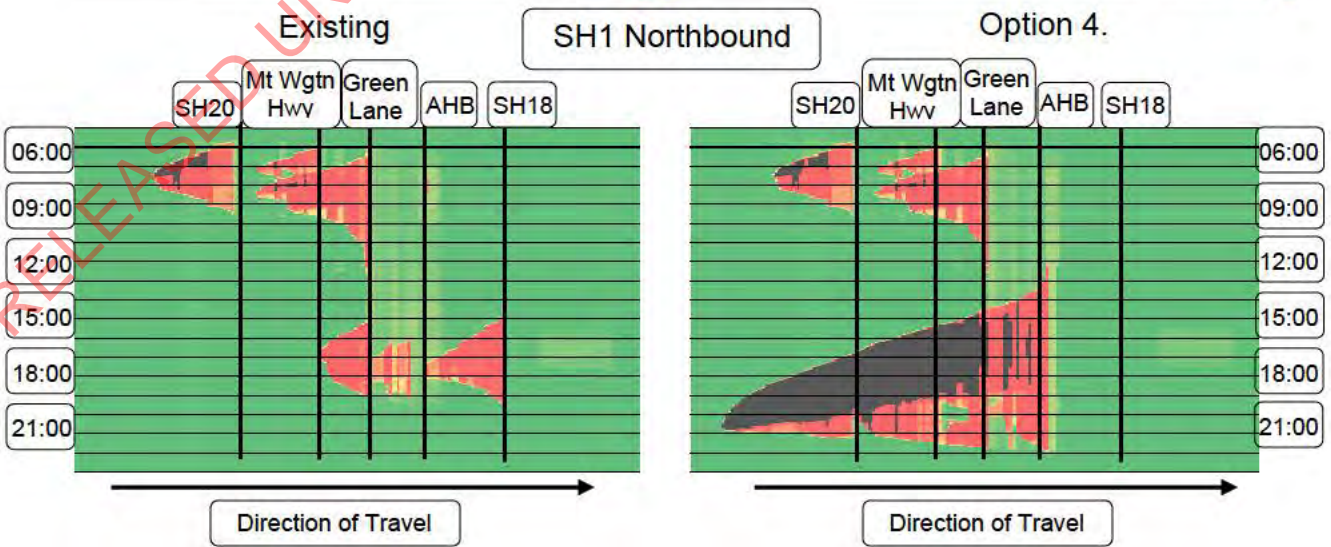
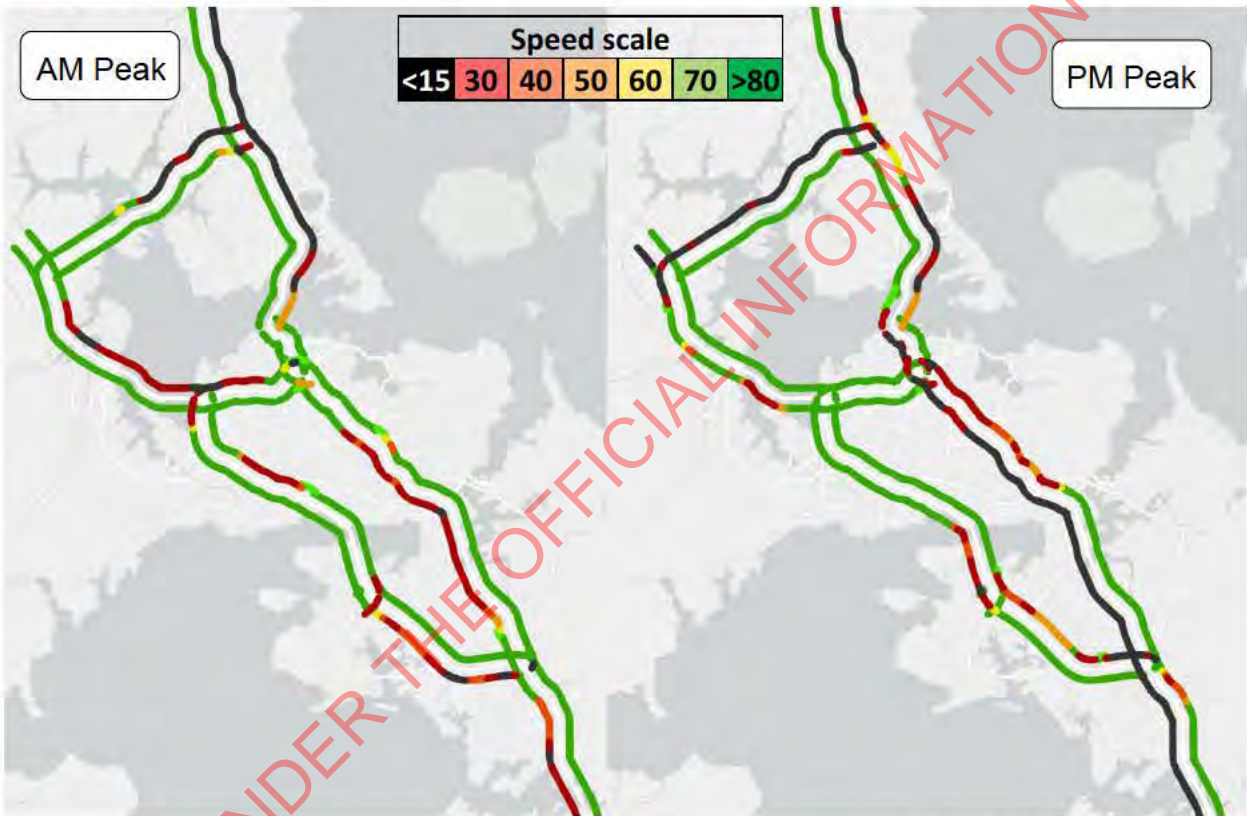
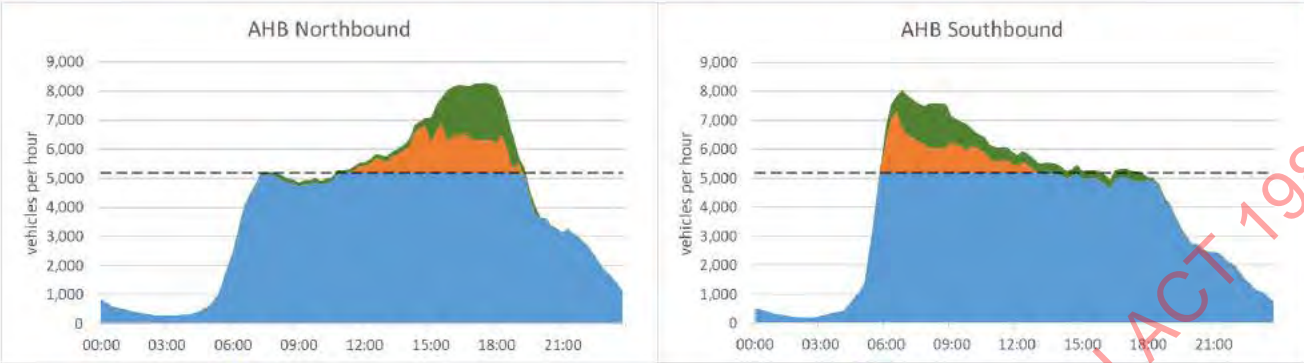

Option 11 – Two lanes for active modes – one on each clip-on (traffic lanes narrowed).
5 traffic lanes in peak direction. 3 lanes in counter peak direction – LEVEL 1 demand reduction

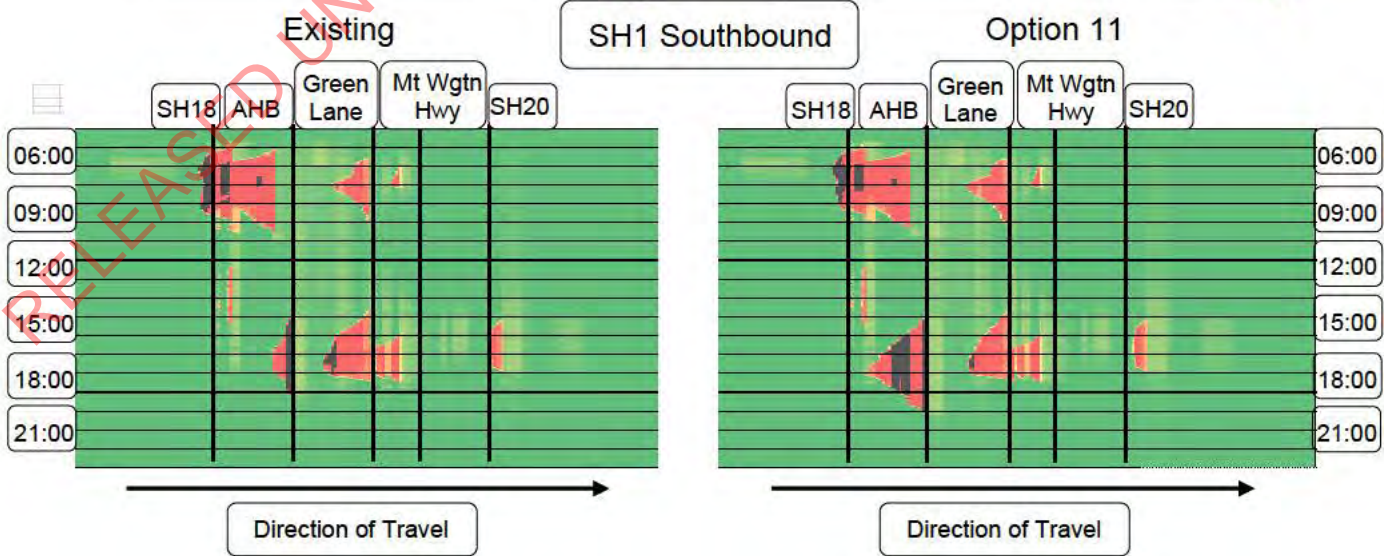
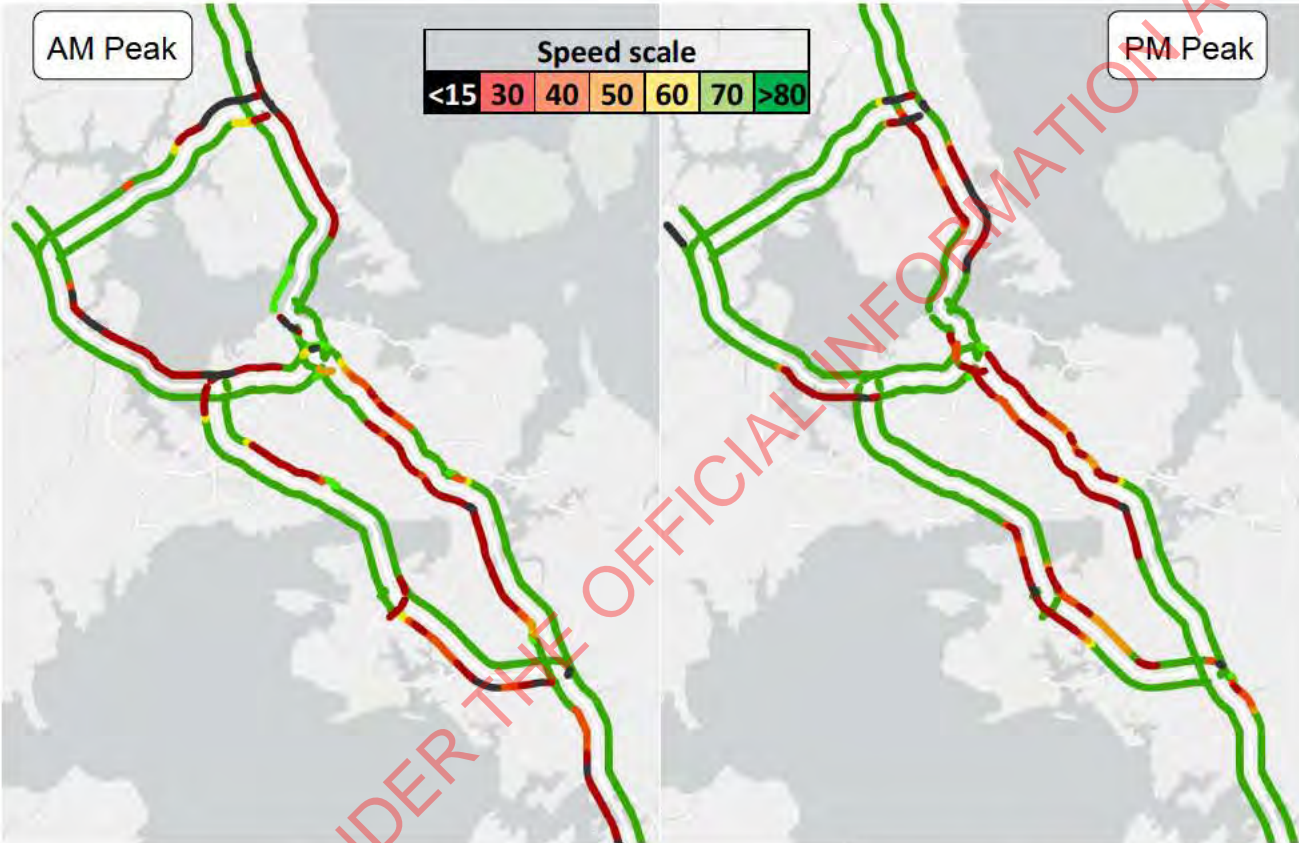
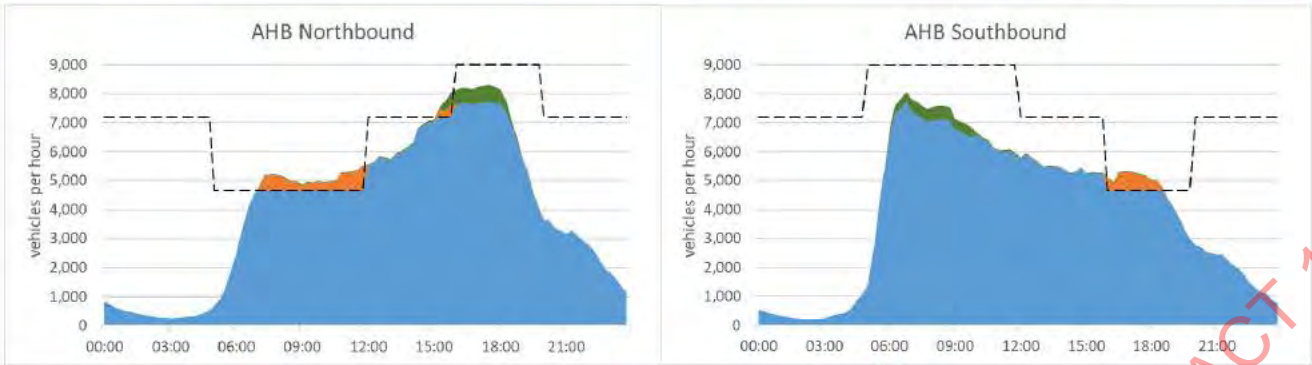

8.4 Effects on Network Resilience

The loss of one or two traffic lanes from a strategic link like AHB is likely to have a negative impact on network resilience and customer journey reliability. To assess this the following incident scenario was run in the CTM on both the base (current) situation and option 3a:

- One northbound lane on the AHB blocked for 1-hour 4pm to 5pm. An incident of this type happens fairly regularly in the afternoon in or just prior to the PM peak (over a dozen times per year).

The heatmaps in Figure 23 indicate worse and prolonged impacts on the southern motorway, with queues extending several kilometres further (past the SH20 interchange) and taking over an hour longer for the network to return to normal operation after the lane blockage is cleared.

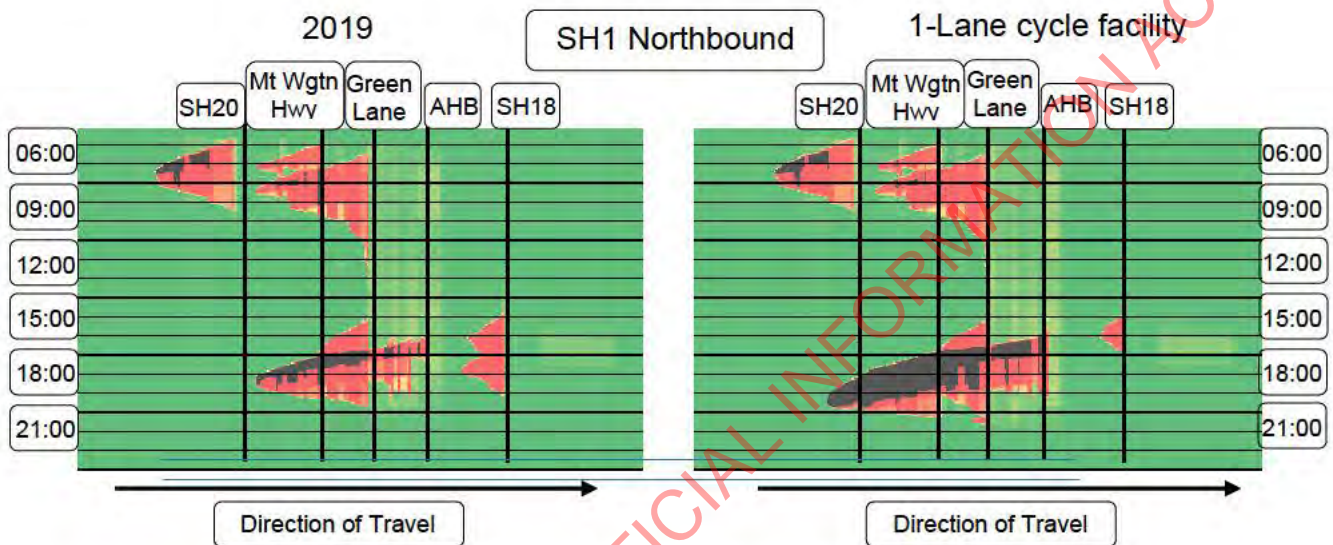

Figure 23 – Option 3a – Impact of example incident scenario on network resilience

8.5 Observations on AHB peak flows from recent data

Note that observations of AHB flows in the PM peak during June 2021 indicated lower peak flows than prior to COVID-19, which were associated with worse congestion on the Southern motorway northbound in the PM peak. The causes were unclear at the time, but it was considered most likely related to NCI long term TTM layout changes – leading to increased PM congestion all along the northern motorway northbound, including across the AHB - which could have attenuated peak flows. If this is the cause peak flows would be expected to return to their higher levels once the NCI project completes.

An alternative cause, or contributing factor, may also migration of some traffic demand away from Fanshawe Street to Grafton Gully to join the northern motorway via the Port link as a consequence of cross-city capacity constraints due to traffic management associated with the CRL works. However, such a migration of demand would be in line with the long-term Central City Access for All traffic strategy. This demand migration may be worsening the bottleneck at Wellington Street on ramp merge, creating a new northbound strategic bottleneck in place of the current one created by the combination of the Victoria Park Tunnel and the Fanshawe / Beaumont signals. This restriction will persist in the long term and may throttle peak arrival flow to the AHB northbound (with the associated increased congestion on the southern motorway persisting also). If this cause is primary, then the effect would be to lessen the relative impact of several of the options assessed (options 3a and option 11).

9 CONCLUSION

The assessment considered the potential impacts on general traffic of 11 different options for an active mode facility on the AHB through re-allocation of existing lane space. The options were a range of temporary and permanent, 1-lane and 2-lane options. Temporary options (which would be installed at weekends and then removed by Sunday evening) were assessed based on typical pre-COVID Sunday trip demands. Permanent options were assessed using typical pre-COVID weekday trip demands.

All options will result in a shortfall of general traffic capacity when considered against typical pre-COVID trip demand levels. There will be two, interrelated responses of the transport system to this demand-capacity mis-match: demand changes (which will reduce the magnitude of the capacity shortfall) and traffic congestion (as the remaining capacity shortfall generates traffic queues from the bridge that propagate upstream over time impacting adjoining sections of the motorway and potentially adjoining arterial and local roads). Both effects were considered in the assessment.

The temporary (weekend) options are likely to lead to extensive congestion over much of the day (8 hours or more), primarily on SH1. For the 1-lane options this is confined to southbound on the northern motorway and is likely to extend past SH18 interchange. For the 2-lane option significant queues are likely to occur across much of the day: southbound on the northern motorway extending past SH18 interchange; and northbound on the southern motorway extending past Mt Wellington at their peak. Much lower impacts would be likely to occur with the short duration southbound closure of 2 lanes using the configuration employed for Auckland Marathon (re-opened by 12pm). This would be likely to result in queuing on the southbound approach to the AHB only over approximately 4-hours and extending to around Tristram Avenue interchange at its peak.

The permanent (weekday) 2-lane options would be expected to lead to a significant increase in network congestion - over a doubling of current weekday motorway network delay hours levels over the whole day. The majority of the impacts would be on SH1 corridors approaching the AHB but would also extend onto other motorway corridors, dependent to some extent on the level of re-routing to SH18 to use the Upper Harbour bridge. However, given the large capacity shortfall these options create compared to current (pre-COVID) demand levels and the limited time for the study, the level of confidence in the traffic demand reductions used for assessing the 2-lane options is relatively low and warrants further consideration.

The permanent (weekday) 1-lane options would be expected to lead to a more modest, but still significant increase in congestion across the motorway network (between 17% and 70% increase in motorway network delay hours). For the best performing of the 1-lane options there is no significant impact in the AM peak, but increased congestion in the PM on both the northern and southern motorway corridors approaching the bridge. On the northern motorway this starts in the interpeak and extends into the PM peak. On the southern it starts around 3pm with queues exacerbating the major bottleneck at Green Lane once they reach there. This indicates the lack of interpeak capacity on the AHB may be the underlying issue for the 1-lane permanent options. Further investigation into likely achievable capacities on the AHB and its approaches with proposed layouts for the active facility, along with consideration of day-to-day demand variability would be required to better understand the potential magnitude of impacts.

Predictably option 11 (the only option without a reduction in the number of traffic lanes) has the least impact on general traffic (a modest 8% increase in motorway network delay hours across the day). The assumed demand reductions offset capacity loss in the direction of predominant demand, and with sufficient interpeak capacity remains to prevent inter-peak congestion running into the PM peak. However, a loss of some capacity for the 3-lane configuration is likely to lead to some increase in congestion in the counter-peak direction (northbound in the AM peak, southbound in the PM peak). This is due to the likely layout changes required to accommodate the active facility on each clip-on.

A further consideration for all options that reduce the number of traffic lanes is the loss network resilience this would bring. Incidents block one or more lanes on the AHB during, or in the lead up to, peak periods relatively frequently (at least once every 2-3 weeks). With any reduction of traffic lanes this will lead to longer resulting queues and a longer time for network operation to return to normal once all lanes are re-opened.