

Suppression Systems

Contents

Suppression Agents.....	5
Fire Suppression	5
Natural Suppression.....	5
Water	5
Foam.....	6
Factors Affecting Foam Effectiveness	6
Design Codes for Foam.....	7
Gaseous Systems	7
Halon systems.....	7
Gas Flooding.....	7
Life Safety Considerations.....	8
Carbon Dioxide	8
Automatic Sprinkler Systems	9
Purpose.....	9
Reliability.....	9
Sprinkler Head Operation	9
Sprinkler Heads.....	9
Type of Heads.....	10
Head Operation.....	10
Entrainment Process.....	10
Response Time Index	10
Speed of Operation	12
New Zealand Standards for Sprinklers	12
Commercial Sprinkler Systems	13
Definition	13
Sprinkler Installation	13
Advantages	13
Sprinklers for Houses.....	14
Introduction	14
Independent System	14

Combination System	14
Suitability.....	14
Related Documents.....	14
Terminology.....	15
Assumed area of operation	15
Authority having jurisdiction.....	15
Cut off sprinkler	15
Density of discharge.....	15
Design flow.....	15
Design pressure	15
Design point	16
Seismic resistance	16
Classes of occupancy	16
Extra light hazard	16
Ordinary hazard	16
Extra high hazard	16
High piling limits	17
Fire hazard categories of materials	17
Process risk.....	17
Types of Systems	18
Sprinkler System Categories	18
Conventional Systems	19
Conventional Sprinkler Systems.....	19
Wet pipe system.....	19
Wet pipe system design and coverage.....	19
Alternate wet and dry pipe system.....	19
Composite valve.....	19
Installation of Sprinklers	19
Dry Pipe System	20
Special conditions	20
Tail end alternate wet and dry pipe system.....	20
Pre-Action System.....	20
Operation of Pre-Action system.....	20
Detection Sprinklers Temperature rating	20
Anti-freeze system.....	20
Tail end anti-freeze system	20
Alternate system	21

Deluge Systems.....	22
Deluge Systems	22
Purpose.....	22
Deluge Sprayers	23
Deluge Spray Heads	23
Multiple jet controls.....	24
Main Components of Wet Systems	25
Key components	25
Sprinkler Room or House	25
Main stop valve	25
Alarm Gong Stop Valve	25
Test and Drain Valve	26
Brigade Inlet Connection	26
Brigade Booster Control Wheel	26
Towns Main Pressure Gauge	26
Alarm Valve Assembly	26
Alarm Gong.....	26
Booster Pump Controls	27
Sprinklers	27
Glass Bulb Sprinkler Head Construction.....	28
Fusible Link Sprinkler Head Construction	28
Sprinkler Head Coding	29
Other Types of sprinklers	29
Sprayers.....	30
Sprinkler System Water Supplies - Types of Water Supply	31
Introduction	31
Primary Supply	31
Secondary Supply	31
Protection of Towns Mains	31
Classes of Water Supply.....	32
Classification	32
Tank capacity	32
Design Criteria	33
Early Suppression Fast Response: ESFR	33
Water Mist.....	34
Entrainment of water droplets.....	34
Fire Brigade Systems - Fire Hydrant Systems for Buildings	35

Fire Hydrant	35
Building Pumps	35
Pre Inlet Pressure.....	35
Outlet Pressure	35
Flow Rate.....	35
Standard	35
Types of Systems	36
Dry System.....	36
Wet System.....	36
Charged System	36
Number of Outlets Required.....	36
Measurement of Arc	36
Protected Lobby	36
Fire Service Inlet	36
information	37
Pumps.....	37

Released under the Official Information Act

Suppression Agents

Fire Suppression

The burning process is a continuous chemical reaction between fuel particles and oxygen. It spreads in a fire because of transfer of heat. For fire to continue, the following four things are needed:

- Fuel
- Oxygen
- Heat
- Continuous chemical reaction

These are often represented by the fire tetrahedron. Take away one, and the fire goes out.

In planned fire extinguishments, the removal of one of the above is achieved by the application of a suppression agent or a suppression technique.

Natural Suppression

Often, fires remain confined to the item first ignited. Where there is little fuel close enough to become involved in the fire, self-extinction occurs.

Fires that start in rooms with closed doors and windows may self-extinguish due to inadequate supply of oxygen.

Many fuels, such as timber, require an external heat flux to be supplied to maintain the continuous chemical reaction. In a fire this may be supplied by burning adjacent fuel, but if that goes out or moves, the fire may self-extinguish due to lack of heat.

Water

Water is the most widely used suppression agent for fires. It is non-toxic, abundant and inexpensive. It has an exceptional capacity for absorbing heat, far higher than any other common material. For example, 1 litre (1kg) of water can absorb 5 mega joules (MJ) of heat from a flame.

The conversion of applied water to steam also has the effect of diluting the available air. Water in a fire increases in volume by several thousand times and this has the effect of displacing the oxygen that could continue the combustion process.

We can assess the effect that water would have on a fire by comparing the heat that it can absorb to the heat that the fire is generating.

When cold water is sprayed onto a fire, the following heat absorption processes occur in turn:

- water is heated from ambient temperature to its boiling point at 100°C absorbing about 0.3MW/l/s
- boiling water is converted to steam at 100°C absorbing about 2.3MW/l/s
- steam is heated from 100°C to the local fire temperature absorbing up to 3.8MW/l/s

In principle, if water were used efficiently, the above calculations show that only a few litres per second could extinguish a fully developed room fire.

However, in practice, the application of water is never efficient. Excessive amounts of water are commonly used, which often causes much or more property damage as the fire. This excess liquid runs away without becoming involved in cooling the fire and vapour leaves the fire without being heated to fire temperatures.

Foam

Foam suppression systems have been used extensively for many years, particularly in the petrochemical and process industries for the suppression of flammable liquid fires.

There are a number of actions that take place in the suppression process:

- radiation is prevented from reaching the fresh fuel because the foam is applied to the fuel surface
- it cools the fuel surface as water drains from the foam
- the foam suppresses vaporisation of the fuel into the air above where it can mix with oxygen
- it provides a barrier between the fuel vapour and the air

Whilst it is relatively easy to list the characteristics of foam that make it useful for liquid fires, it is not easy to determine which of these is the most important.

Factors Affecting Foam Effectiveness

The factors controlling foam effectiveness depend to a large extent on maintaining the barrier between fuel vapour and air. This depends on a number of factors:

- It is necessary to consider how is the foam delivered and what expansion is achieved
- Though drainage does an important job in cooling the fuel below, too rapid a drainage time may allow the foam layer to disintegrate and allow the fire to re-ignite
- The foam is of no benefit if it cannot be delivered onto the fuel surface through the fire plume

- An assessment has to be made of what quantity of foam is carried away by the plume, which could clearly be very considerable in a large fire
- The foam must spread effectively over the surface and provide a stable layer
- The action of heat and radiation will tend to destroy the foam and clearly it has to survive the action in order to be of use.

Design Codes for Foam

Despite the fact that the above parameters are difficult to quantify, fixed and portable foam systems are widely used. There are a number of design guides and codes that are used to design systems to deliver foam in an effective manner in relation to the fuel and to the delivery system.

Gaseous Systems

Most gaseous suppression systems work by diluting the oxygen available to the fire. The gases used for these purposes include; carbon dioxide, steam and nitrogen. There are also commercially available mixes.

Halon systems

The use of gaseous systems has greatly increased with the ban on the use of halon fixed extinguishing systems. Halons are a major source of contamination of the ozone layer and are banned by law. Halons were useful in that they operated by interfering with the chemistry of the chemical chain reaction. They could be used in relatively small quantities, and were non-toxic to humans. They found huge applications in computer rooms and other sensitive risks. Halon compounds could be stored very compactly and discharged reliably with no immediate risk to the occupants of a room. These now have to be replaced by alternatives.

Gas Flooding

Flooding a space with an inert gas would prevent ignition, or fire spread, or extinguish an established fire. The main disadvantage is that a large quantity of gas is needed to reduce the oxygen concentration in the compartment to 12% or less --at which point suppression will occur. The means of suppression is, principally, insufficient oxygen to support the reaction, but also to absorb heat from the fire.

There are a number of issues associated with the design of inert gas systems.

The quantity of gas that must be stored in order to reduce the amount of oxygen is large. This has an impact on storage and delivery.

The space into which the gas is injected must be reasonably sealed to ensure low oxygen concentrations can be maintained long enough to affect suppression.

The gas concentrations required to suppress a fire are too high to support life. There is a risk that any system of this type could pose a risk to building occupants if it was discharged accidentally.

Life Safety Considerations

Life safety considerations have to be addressed properly when installing gas- flooding systems. It has to be assured that any occupants within the compartment can safely leave before gas is discharged. The same restriction applies to spaces not normally occupied but where people might be present for maintenance or other purposes. Escape during discharge is difficult because of the reduction in visibility and noise. Consideration should be given to escaping gas into lower floors, etc.

Carbon Dioxide

Carbon dioxide (CO₂) has a number of properties that make it a desirable suppression agent:

- It is non-combustible
- It does not react with most substances
- It provides its own pressure for discharge from the storage container
- It has good discharge properties – it spreads
- It does not conduct electricity
- It leaves no residue, thus no clean up is needed

CO₂ is limited as a suppression agent on Class A fires because:

- it has a low cooling capacity
- the enclosure must be well-sealed for the CO₂ to be effective
- fires involving chemicals, such as cellulose nitrate, contain their own oxygen supply.
- fires involving reactive metals and hybrids such as sodium, potassium, magnesium, titanium, zirconium, and the metal hydrides, decompose CO₂ .

Automatic Sprinkler Systems

Purpose

Automatic fire sprinkler systems are intended to control the unwanted outbreak of fire.

Reliability

The action of sprinklers on a fire is so reliable that the risk of a severe fire developing in a sprinklered building is very low.

However, there is still a small risk that the sprinklers will not operate when they should and the fire could become large enough to threaten the structure or the fire barriers. For example, some fuels can generate large amounts of smoke with very little initial rise in ambient temperature and would not operate in time to prevent the fire becoming large.

Sprinkler Head Operation

The convection currents created by a fire will carry the heat plume upwards until it strikes the ceiling. The heat will then jet stream across the ceiling.

As the ceiling temperature rises, it affects any sprinkler heads in the local area.

The increasing temperature affects the liquid and air bubble within the sprinkler bulb making it expand so that eventually the glass bulb fractures, thereby releasing the water. The water, in turn strikes the deflector plate, spraying onto the fire.

Sprinkler Heads

Each sprinkler head is a combination of a detector and means of dispensing a suppression agent in one device. The strength of the system is that the number of sprinkler heads required to contain the fire are the only ones that will operate. Traditionally, systems have been designed to contain fire but sprinklers, in practice, often achieve fire suppression.

Approval of sprinkler heads requires that the manufacturers demonstrate that water cover predetermined area.

actuation of a sprinkler head requires that the sensitive element be heated to a predetermined temperature.

This temperature is varied in different installations to cope with differing ambient temperatures, but in an office environment, for example, a temperature of around 70°C would be typical.

Type of Heads

Two types of element are in common use:

- The first relies on a quartz bulb that contains a liquid and a small bubble of air. As the bulb is heated, the liquid expands; the bubble shrinks and then is absorbed. After that point any further heating of the bulb will cause the liquid to expand further and the bulb will shatter.
- The second is a solder link element, which relies on the solder reaching a preset temperature and then melting.

Head Operation

Heat is transferred to the sprinkler head by convection from the ceiling jet. The rate at which heat is transferred depends on the heat release rate of the fire in the first instance. Hotter fires will operate a sprinkler head sooner.

The higher the ceiling, the more entrainment of cool air there will be into the rising plume. The higher the ceiling, the cooler the smoke and the longer it will take a head to operate.

The spreading ceiling jet continues to entrain air and the further it travels, the cooler it will become. Therefore, the further the sprinkler is from the fire, the longer it will take to operate.

The heat transfer to the element also depends on the velocity of the spreading gases. As the jet spreads across the ceiling the gases slow, and this effect must be taken into account when trying to estimate the time of sprinkler response.

Entrainment Process

The entrainment process cools the smoke as it rises and cools the smoke as it spreads. One consequence of this is that in tall spaces, the fire has to become larger before the sprinkler heads operate compared to the situation in lower spaces. In some spaces where the fire load is relatively limited, the fire may never become large enough to operate the sprinklers at roof level or the sprinkler may take a long time to operate. Whilst there are ways of overcoming these issues in a design situation, they must be recognised.

Response Time Index

The drive towards fast response in sprinkler actuation was driven by the requirements in the USA to develop a domestic sprinkler system. Rapid response was seen as important and, therefore, tests had to be developed to measure the response and to determine those sprinklers that were suitable. The application of fast response heads now goes well beyond the domestic arena, and such heads are particularly important in in-rack sprinkler systems for protection of high-rack storage, as well as in ESFR sprinklers.

The response time index, known as the RTI, is the key in determining whether a sprinkler will operate slowly or quickly in a fire. Essentially, it is determined by the mass of the heat-sensitive element but the area of the element, which can be exposed to fire, is also affected by it. This is important for solder-link elements that can have very light elements of large

area. The design of a sprinkler head clearly has to balance the lightness of the element against strength and robustness.

Sprinklers that have an RTI less than about $30 \text{ (m.s)}^{1/2}$ are generally regarded as quick response or fast response. In quartz bulb sprinklers, the fastest elements rely on bulbs that are only 2.5 or 3mm diameter. Standard response sprinklers are about 8 mm in diameter, though questions have been raised concerning fast sprinklers much larger bulbs were common and many are still in use.

Plunging it into a wind tunnel at high temperature and measuring its time of operation is how the RTI of a sprinkler is measured. In a real fire, the sprinkler may heat up more slowly than in the test, and loses a proportion of the heat it gains from the fire to the associated pipe work. This conduction loss has been assessed and can be incorporated into some predictive models for sprinkler operation. It is known as a C factor and the higher it is the more prone the sprinkler head is to conduction loss and the longer would be its time to operation. This becomes more marked in slower fires.

Released under the Official Information Act

Speed of Operation

As the fire gases heat a sprinkler element, the temperature of the element always lags a bit behind the temperature of the gases. The above curve illustrates how two typical sprinklers might heat up when exposed to fire gases indicated by the red curve. The sprinkler with a low RTI is able to heat up rapidly and follow the fire gas curve quite closely. The sprinkler with the greater RTI heats up more slowly and lags further behind the fire gas temperature. The effect is that the fast sprinkler reaches its operating temperature. In this example, in about half the time it would take the standard sprinkler to do so.

This illustration is fairly typical. It is found that under reasonably rapidly growing fires, fast response heads would operate in 1 or 2 minutes whilst standard response heads might take 4 or 5 minutes. More importantly, depending on how fast the fire is growing, the fire heat release rate is much smaller when the fast response head operates. Not only does this have an effect on the potential damage inflicted by the fire, but it also affects the rate of smoke production.

As noted previously, the sprinkler cannot operate until the fire gas temperature reaches the sprinkler head operating temperature, and even then it will not operate at once as the element always lags a bit behind the fire gas temperature. After the sprinkler operates, it discharges water onto the fire. In general the water spray is a mixture of small and large drops. The large drops are able to penetrate the fire plume, because they have more downward momentum. They perform the function of wetting unburned fuel, cooling it, and thereby limiting or preventing spread of fire. The smaller droplets in the spray tend to evaporate before they can reach the fire, but they still have the beneficial effect of cooling the smoke layer which limits heat damage and very seriously limits any possibility of progression to flashover.

Whether or not the sprinkler spray is immediately effective in bringing the fire under control, depends on a number of factors. If the sprinkler is a long way above the fire, it may be that few drops can penetrate the plume and the wetting at ground level may be limited. Alternatively if the material on fire is shielded in some way from the sprinkler spray, such as by shelving, then the fire may continue to grow and spread.

If the fire is sufficiently controlled so as to bring the hot layer temperature down below the operating temperature of the sprinkler, then no further heads will operate. If however the fire plume and hot gases are insufficiently cooled for whatever reason, further heads are likely to operate. Only one or two heads controls most sprinklered fires.

New Zealand Standards for Sprinklers

Standards currently in use in New Zealand are:

- NZS 4515: Fire Sprinkler system for Residential occupancies
- NZS 4541: Automatic Fire Sprinkler Systems

Commercial Sprinkler Systems

Definition

NZS 4541 defines a Sprinkler System as:

- The water supply pipes from the boundary of the protected premises to the sprinkler valves;
- Any static water supply on the protected premises:
- Any pump providing water supply and its driving engine, motor and control equipment
- The control valves and all appurtenances thereto;
- The main stop valve anti-interference device
- Any fire alarm signalling device
- Compressors, air receivers and related equipment forming part of a dry pipe system
- All pipe work, sprinklers and appurtenances downstream of the control valves
- Storage restriction signs
- First aid fire fighting appliances to the extent required by NZS 4541
- Any fire rated wall, door or partition required by NZS 4541

Sprinkler Installation

NZS 4541 defines a Sprinkler Installation as:

That part of the system downstream from and including, the main stop valve.

Advantages

Automatic fire sprinkler systems protect a building or complex from the devastating affects of fire 365 days of the year.

A fire sprinkler system can initiate a local warning alarm as well as alert the local fire brigade, thereby giving early warning of fire in a building or complex.

Control of a fire is best achieved in the early stages of development, thereby reducing the consequences of the fire and limiting damage. Water damage is also limited, due to the smaller amount of water required to control a fire in its early stages of development.

The sprinkler system can be integrated into signalling devices, which can automatically start or stop other systems within a building or complex as required including:

- lift controls
- automatic fire and/or smoke control door releases
- air-conditioning and air exhausting systems

Sprinklers for Houses

Introduction

Sprinkler systems that are designed and installed to NZS 4517: Fire Sprinkler Systems for Houses provide an effective method of property protection.

There are two types of systems:

- Independent System
- Combination System

Independent System

Independent systems require their own pipe network (it is not part of the domestic plumbing system). The system is connected to a water supply via the main house supply. A backflow preventer is required between the house water supply and the sprinkler network

Combination System

A combination system has a potable water reticulation system that supplies the combined domestic water supply demand and the fire sprinkler system water supply demand through a common system of pipe work.

Suitability

These types of sprinkler systems can be installed in domestic occupancies. A domestic occupancy is a home of not more than one household and includes any attached self-contained unit. Multiple adjoining occupancies are considered included -- provided they are separated by fire rated walls.

Related Documents

Reference should also be made to:

- New Zealand Building Code
- AS/NZS 3500:1998 National plumbing and drainage Part 1.2 acceptable Solutions
- AS/NZS 4130:1997 polyethylene pipes for pressure applications
- NZS 4517: Fire sprinkler systems for Houses

Further information and specifications on the sprinkler system can be found in NZS 4517: Fire sprinkler systems for domestic occupancies

Terminology

Assumed area of operation

The assumed area of operation is also known as the assumed maximum area of operation

It is the number of sprinklers likely to operate in any given area involved in fire.

The assumed area varies for each hazard class.

Authority having jurisdiction

The authority having jurisdiction (AHJ) is the body or authority that approves compliance with the Standard.

Where a Standard mentions an AHJ, the Standard will define the authority that approves compliance.

Cut off sprinkler

One or more sprinklers arranged to discharge over the face of a door or end wall of a passageway

Density of discharge

The depth of water discharged in a given period of time expressed as:

- mm/minute

which is equivalent to L/minute/m²

Design flow

The flow rate required to supply all sprinklers discharging over the assumed area of operation to provide the design density.

In the case of residential or large droplet sprinkler heads, it is the flow supply required for the number of heads designed to be operating at the minimum pressure.

Design pressure

The minimum pressure required immediately down stream of the alarm valve to induce the design flow for each area of the protected building.

Design point

Designated by a letter on layout drawings it is the point in a layout that is a hydraulic calculation back to the alarm valve.

Usually classified as 4, 16/18 or 48 sprinkler point and so on according to hazard class

Seismic resistance

All sprinkler systems must be designed and installed to remain operational in earthquake loadings specified in NZS 4203, having regard to the seismic design of the building elements that support or are connected to the system.

Classes of occupancy

Three broad classes of fire hazard are established under the Standard

Extra Light Hazard (ELH)

Ordinary Hazard (OH)

Extra High Hazard (EHH)

Extra light hazard

Non-industrial occupancies where the amount and combustibility of the contents is low.

Ordinary hazard

Commercial and industrial occupancies involving the handling, processing and storage of mainly ordinary combustible materials, unlikely to develop intensely burning fires in the initial stages.

Ordinary hazard is further subdivided into:

- Group 1 (OH1)
- Group 2 (OH2)
- Group 3 (OH3)
- Group 3 Special (OH3S)

Extra high hazard

Commercial and industrial occupancies having high fire loads:

- (I) Where the materials handled or processed are mainly of an extra hazardous nature likely to develop rapid and intensely burning fire (extra high hazard - process risk)
- (II) Involving high piling of goods beyond the limits specified in the standard

High piling limits

The following is a table taken from NZS 4541:2007 (Table 2.2)

Height of storage shall be measured from the floor to the top of the stored materials (including packaging) under consideration.

Ordinary hazard storage limits	
Fire Hazard Category	All mercantile storage
1	3.5 m
2	3.0 m
3	2.4 m
4	2.2 m
5	2.0 m
6	1.2 m

Fire hazard categories of materials

Combustible materials are grouped under four categories for the purposes of determining the density and area of operation of a sprinkler system.

Where combustible materials are shrink-wrapped they are then treated as if they are in the next higher category.

Process risk

Occupancies or storage situations where the combustibles will produce rapid and intense burning fires requiring higher densities than those of an ordinary hazard.

Referred to as **Extra High Hazard "Process Risk"**

Types of Systems

Sprinkler System Categories

Sprinkler systems fall into two broad categories, they are

- Conventional sprinkler systems
- Deluge systems

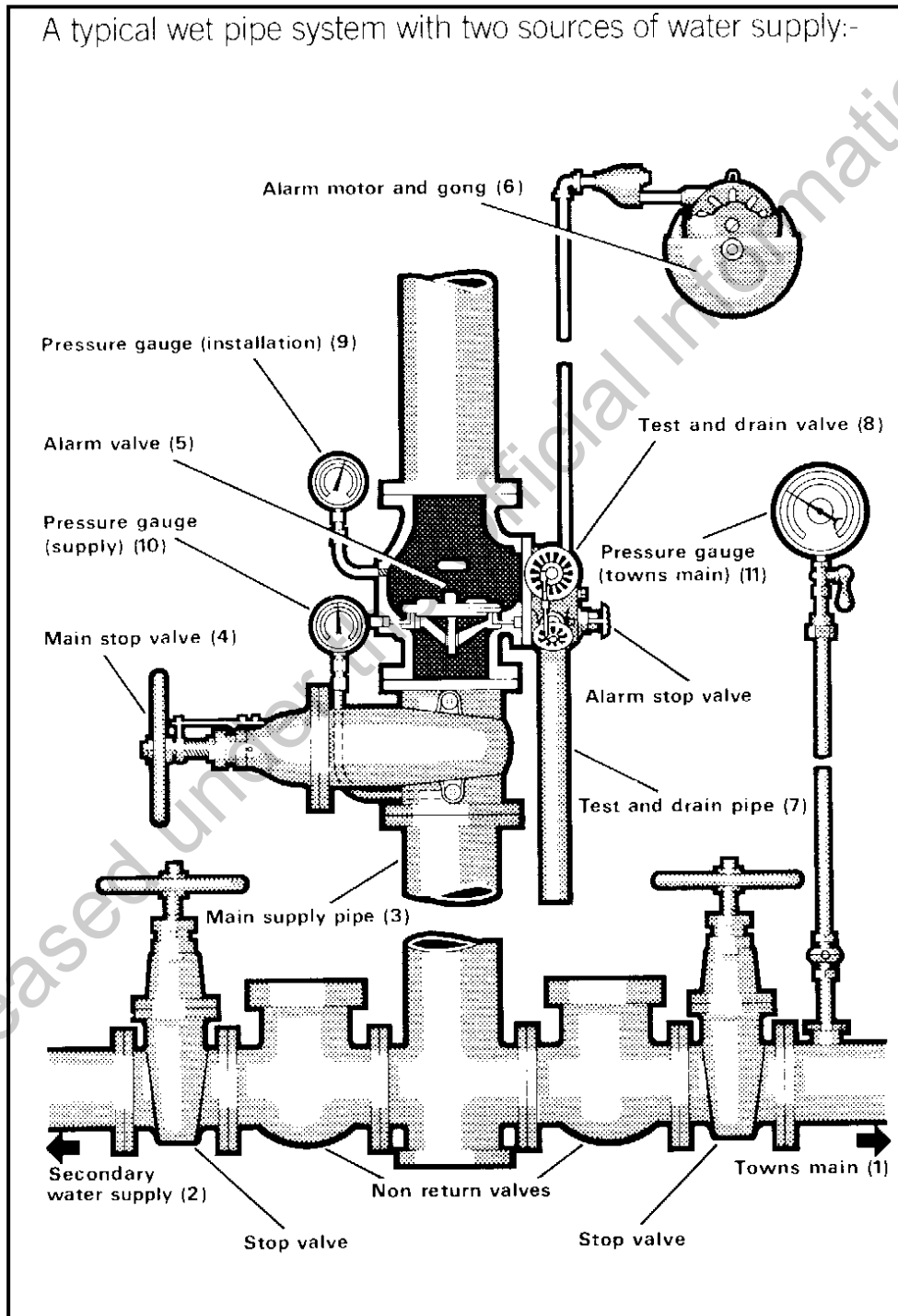

Conventional Systems

Conventional Sprinkler Systems

These systems include:

- Wet pipe system
- Alternate wet dry system
- Wet pipe or alternate wet and dry pipe system incorporating tail end dry pipe system
- Wet pipe systems incorporating tail end alternate system
- Dry Pipe system
- Pre-action system
- Anti-freeze system
- Tail end anti-freeze system

Wet pipe system

Wet pipe systems are used whenever ambient temperatures remain at 4 °C or above unless otherwise permitted by the Standard. Sprinklers may be installed either in the upright or pendent position.

Wet pipe system design and coverage

This system is designed so that the total floor area protected, excluding concealed spaces controlled by one set of control valves, does not exceed 11,000 m²

Alternate wet and dry pipe system

During winter months this type of system is drained of water above the composite or alarm (dry pipe) valve. The drained system is charged with gas under pressure. Water under pressure is still present below the composite valve

Composite valve

Used on alternate wet and dry systems comprising an alarm (wet pipe) valve and an alarm (dry pipe) valve.

Installation of Sprinklers

Sprinklers are normally installed above the range pipes unless the sprinklers are of an approved dry pendent pattern type or if the area is not subject to freezing.

Dry Pipe System

This type of system is normally only allowed in buildings where the temperature conditions are artificially maintained close to or below freezing such as in cold or cool stores, fur vaults and the like or where the temperature is maintained above 70 °C as in drying ovens.

Special conditions

The pipe work must be installed and arranged with adequate slope to allow for drainage.

Tail end alternate wet and dry pipe system

These systems are similar to dry pipe and alternate wet and dry pipe systems except they are of comparatively small extent and form extensions to standard sprinkler installations.

Pre-Action System

This system incorporates two sets of pipe work:

Conventional pipe work with closed sprinkler heads charged with low pressure gas (discharge sprinklers)

Small diameter pipe work fitted with closed sprinkler heads charged with gas (detection sprinklers) designed for use in areas where accidental discharge of water due to mechanical damage to sprinkler heads or pipe work is both unusually high and unacceptable.

Operation of Pre-Action system

Before this system will discharge water, both sets of sprinklers must have operated

Detection Sprinklers Temperature rating

The detection sprinklers on a pre action system may have a temperature rating of only 15 °C.

Anti-freeze system

This is a conventional wet pipe system in which the entire installation is charged with an anti-freeze solution and connected to one or more water supplies.

Tail end anti-freeze system

These are portions of an installation that are arranged to protect a low temperature area by means of an anti-freeze solution but as an extension of the conventional wet pipe system.

Alternate system

Diagram showing an alternate system with accelerator.

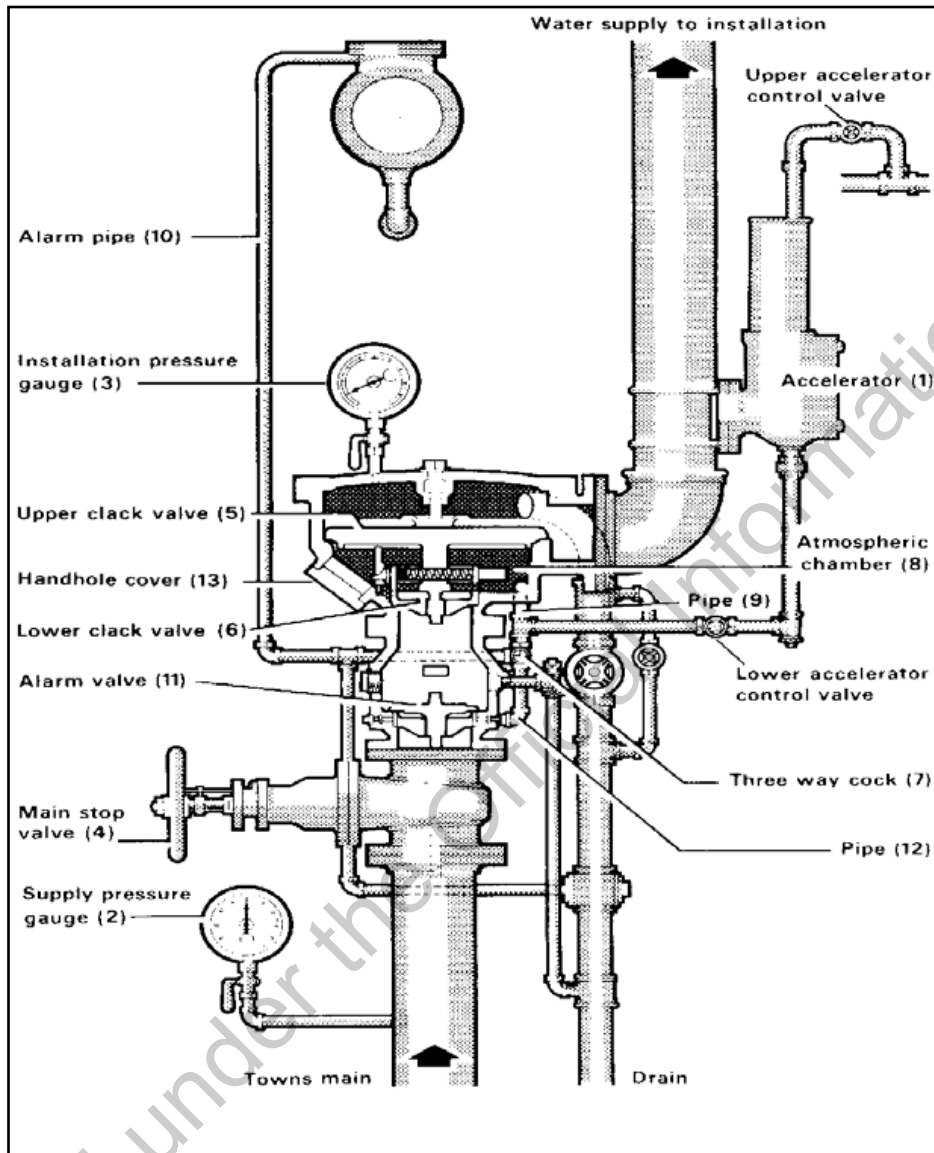

Note: Due to the delayed response when the system is dry, an accelerator or exhauster may be fitted to aid in the removal of the air from the system.

Deluge Systems

Deluge Systems

Deluge systems normally comprise open sprinklers that are either:

- Manually operated
- Controlled by an automatic sensing device

Purpose

Deluge systems are designed for protection of special risks by suppressants or cooling to permit controlled burning or cooling to prevent heat damage.

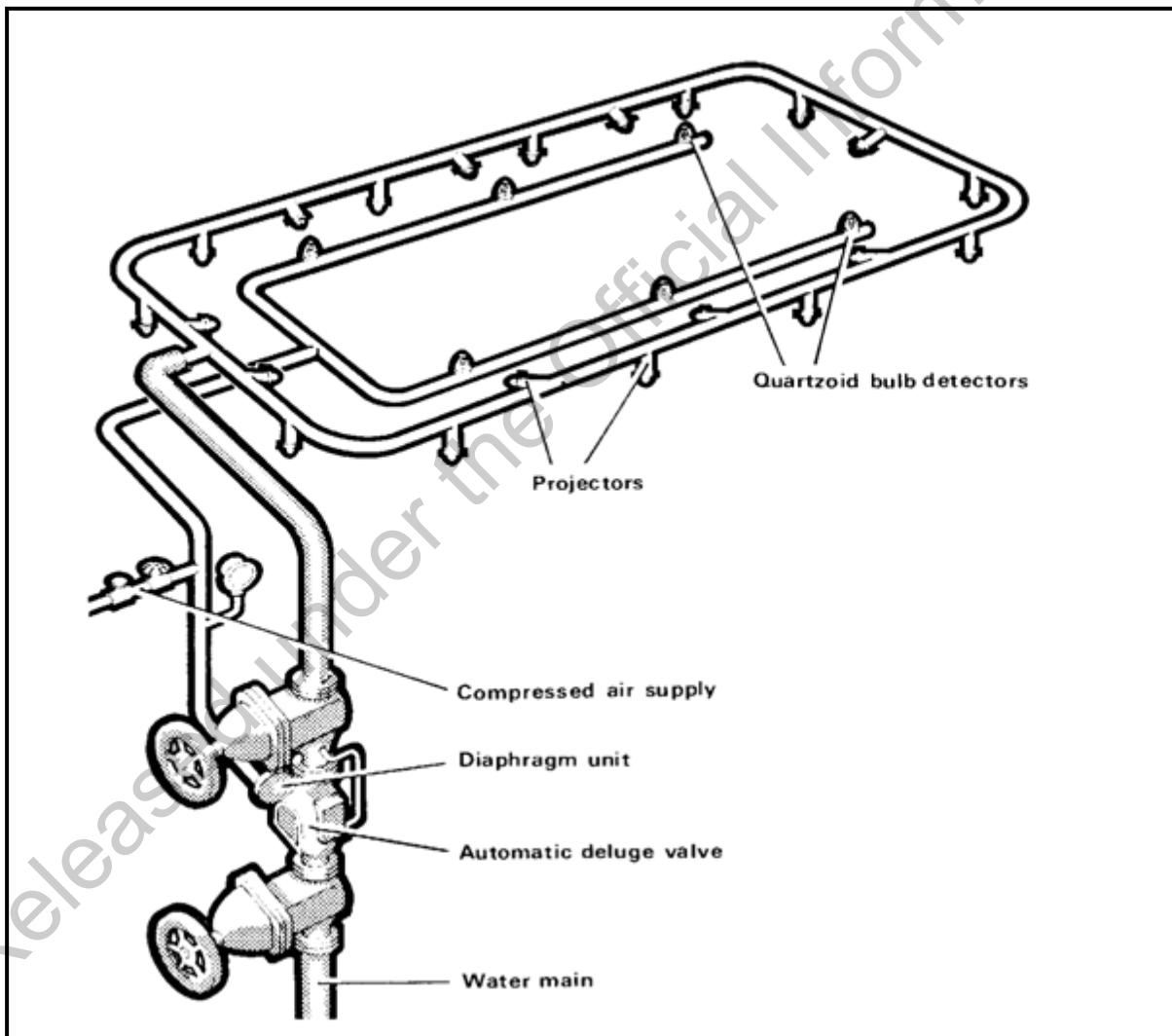

Deluge Sprayers

Deluge systems are normally designed for extra high hazard areas and usually incorporate either

- Medium velocity sprayers
- High velocity sprayers

Deluge Spray Heads

The diagram below shows two examples of the heads that may be incorporated into a deluge system.

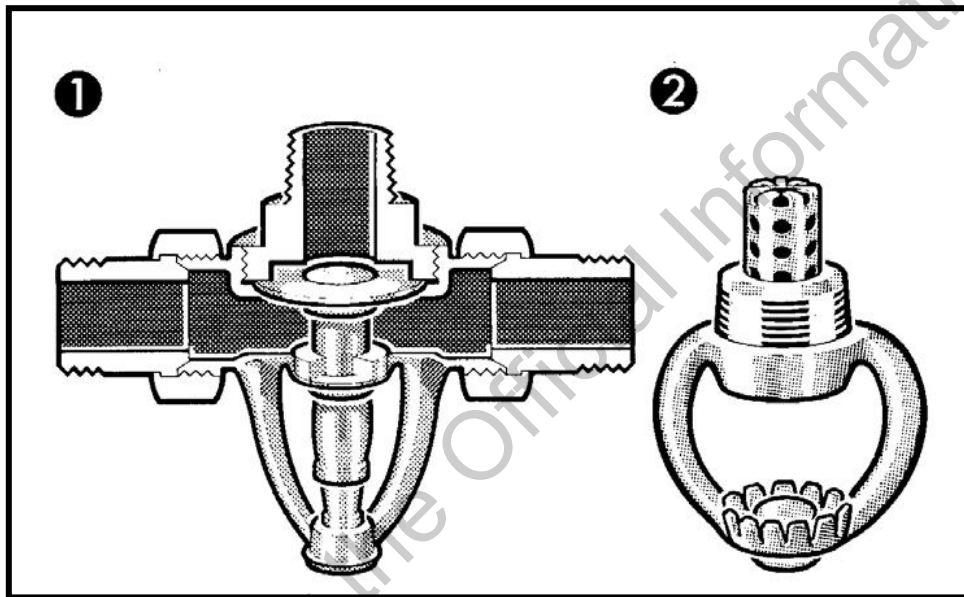

(1) Automatic Control Head.

(2) An Open Sprayer

Multiple jet controls

MJCs are heat sensitive sealed valve controlled outlets, using either a glass bulb or soldered links and levers. They are used to control sets of sprinklers and medium velocity or high velocity sprayers of the open type.

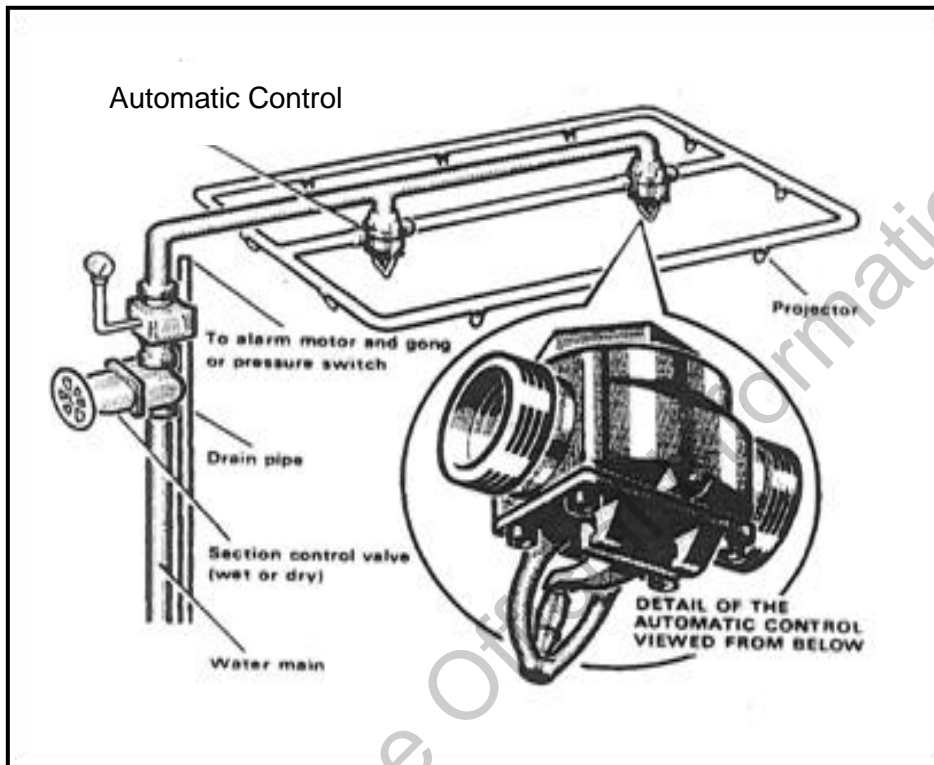

Main Components of Wet Systems

Key components

Fire fighters must be able to identify the following key components of an automatic fire sprinkler system:

- Sprinkler Room or House
 - Main Stop Valve
 - Alarm Gong Stop Valve
 - Test and Drain Valve
 - Fire Brigade Control Valve
- Brigade Inlet Connection
- Installation Pressure Gauge
- Towns Main Pressure Gauge
- Alarm Valve Assembly
- Alarm Gong
- Booster Pump Controls

Sprinkler Room or House

A designated area where the sprinkler control valves are located.



Fire Brigade PFA Keys are used to gain entry

Main stop valve

Controls flow of water from water supply to Installation.

Only turned off on the instructions of the NZFS Officer In-charge. Normally secured in the open position fitted with anti-tamper device

Alarm Gong Stop Valve

Controls flow of water to water driven alarm gong .

Test and Drain Valve

Used by the Fire Brigade to drain down the sprinkler system

Brigade Inlet Connection

Male Instantaneous coupling for Fire Brigade to connect to supplement installation supply and pressure.



Triangular key normally opens cabinet box

Wire glazed panel provided to enable forced entry if necessary

Brigade Booster Control Wheel

Hand wheel on some systems that must be opened prior to Fire brigade boosting the water supply and pressure.

Towns Main Pressure Gauge

Fitted to each reticulated water supply to indicate mains pressure

Alarm Valve Assembly

The alarm valve assembly is located just above the Main Stop Valve on the installation side of the system. It contains the clack valve assembly.

Alarm Gong

Usually located close to the Sprinkler House on an exterior wall.

A water driven (Pelton Wheel Motor) alarm gong

Water may be discharging from a pipe on the alarm gong when it is sounding

Booster Pump Controls

Some sprinkler systems will be fitted with electric or diesel stationary motors that drive pumps to increase the water supply to the system

Instructions are provided on SHUT DOWN and START UP procedures.

Read the instructions provided before acting

Sprinklers

Sprinklers for use on automatic fire sprinkler installations come in a variety of styles and patterns

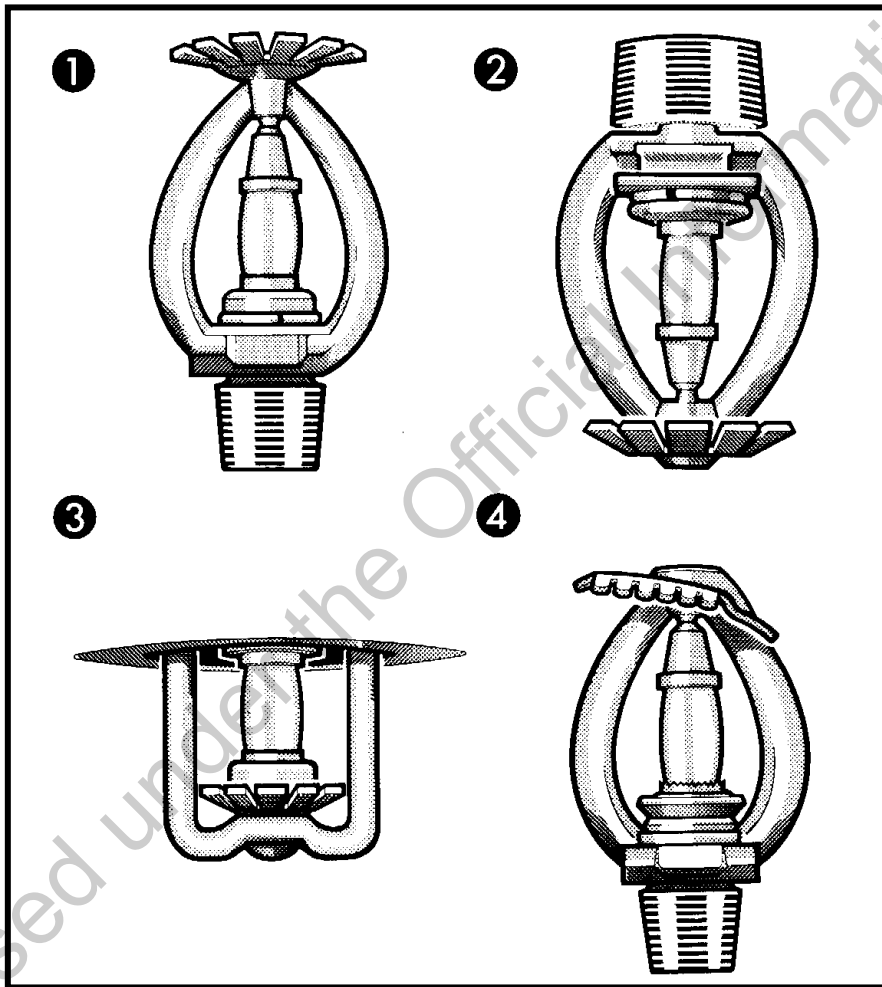

Various Sprinkler Heads

Glass Bulb Sprinkler Head Construction

The following shows the components of a glass bulb sprinkler head

Heat causes the liquid in the bulb to expand. The bulb shatters as the liquid tries to compress thus releasing the water onto the deflector

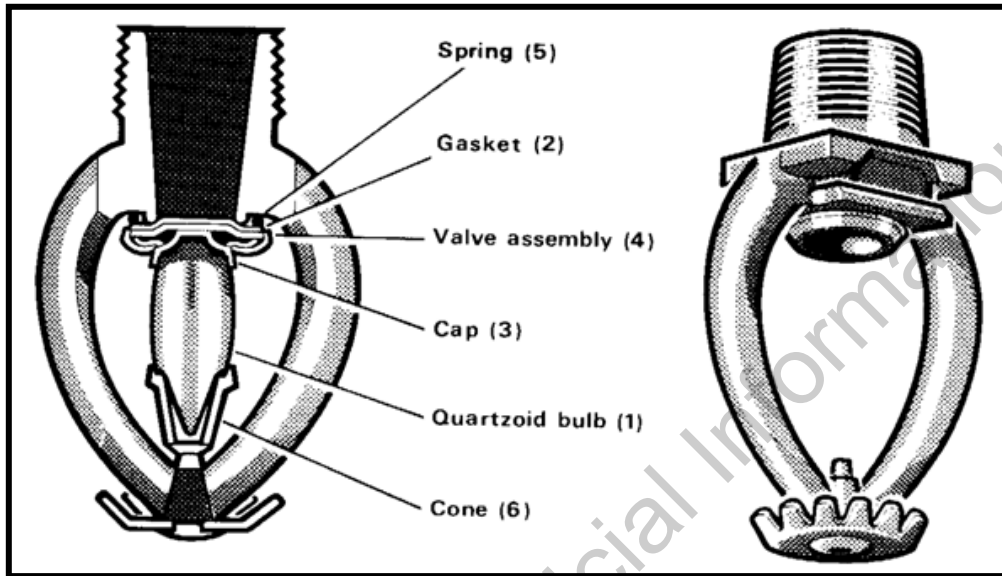

Quartzoid Bulb Type Sprinkler Head

Fusible Link Sprinkler Head Construction

The following shows the components of a fusible link sprinkler head

Heat causes the fusible link to melt thus releasing the stopper device thus releasing the water onto the deflector

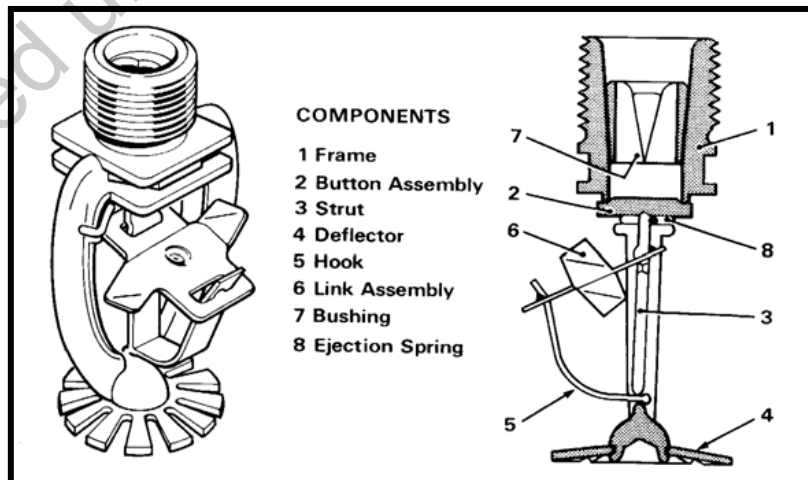

Sprinkler Head Coding

The colour code for sprinkler heads is shown below. The colours distinguish the different temperature ratings.

Fusible Link Sprinklers		Glass Bulb Types	
Temperature Rating °C	Colour of yoke arms	Temperature Rating °C	Colour of bulbs
57-77	Natural (uncoloured)	57	Orange
80-107	White	68	Red
121-141	Blue	79	Yellow
163-191	Red	93	Green
204-246	Green	141	Blue
260-302	Orange	182	Mauve
320-343	Black	227-260	Black

Other Types of sprinklers

Sprinklers are manufactured in a variety of forms depending on the installation type and area of operation

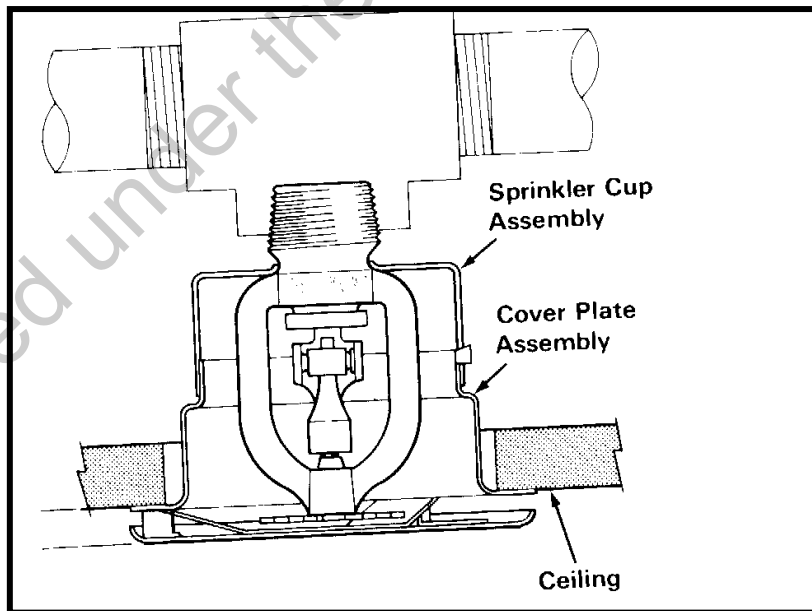

Recessed Sprinkler Head

Sprayers

Sprayers usually refer to sprinkler heads for use on medium and high density discharge deluge systems

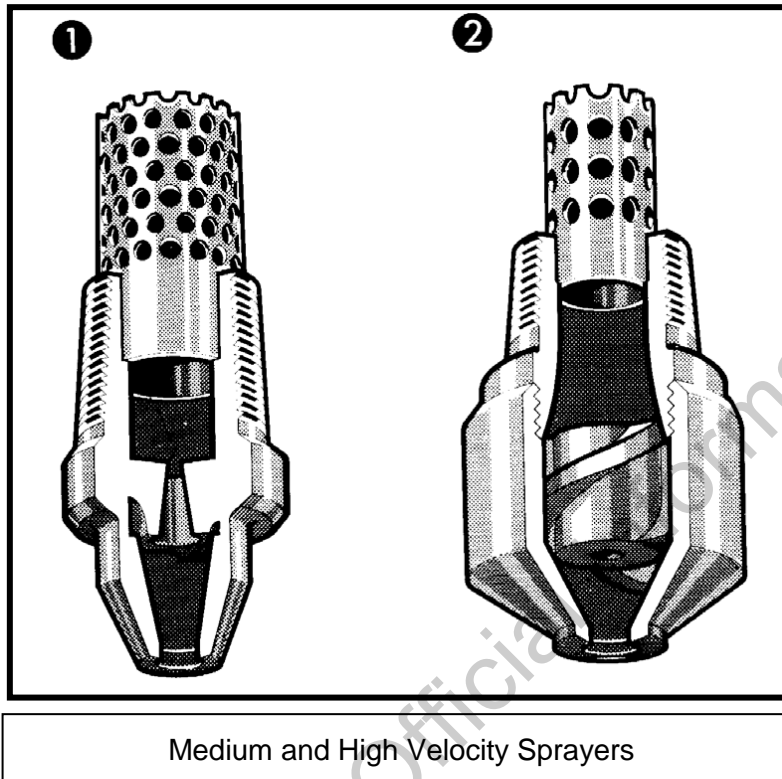

Sprinkler System Water Supplies - Types of Water Supply

Introduction

A sprinkler system depends upon its water supply and based upon a building's fire hazard classification will determine the number of water supplies the sprinkler system must have.

Water supplies are generally classified as primary or secondary. The water supply is defined by its flow in pressure

Primary Supply

A primary supply shall be one of the following:

- (a) A town main, boosted town main, or supplemented town main provided that any pump is driven by a diesel engine.
- (b) A diesel engine driven pump, taking water from an approved source other than a town main.
- (c) An elevated tank
- (d) A pressure tank (extra light hazard only)

Secondary Supply

A secondary supply shall be one of the following:

- (a) A town's main, boosted town main, or supplemented town main where any pump is either diesel engine or electric motor driven
- (b) A diesel engine or electric driven pump, taking water from an approved source other than a town main
- (c) An elevated tank
- (d) A pressure tank (extra light hazard only)

Protection of Towns Mains

Back flow prevention is required to protect towns mains from cross contamination from the installation and secondary supplies or private fire mains.

Classes of Water Supply

Classification

Water supplies are classified as follows:

- Class A
- Class B2
- Class C 2
- Class C1

Class A - Dual superior supply

Two approved supplies, both of which shall be carried independently to a combined main within each control valve enclosure, at least one of which shall be a primary supply, but only one of which may be dependant on a town's main.

Class B2 - Private site fire main

A private reticulation system which complies with the Standard and is reserved solely for fire purposes, being charged with water and normally pressurised, comprising at least one ring and supplied by two approved water supplies, at least one of which shall be a primary supply, but only one of which may be dependant on a town's main.

Two connections shall be carried independently to a combine main within each valve enclosure.

Isolation valves shall be provided at each connect with the fire main and so as to ensure there are at least two isolation valves between any two connections.

Class C Single supply

One approved primary supply

Tank capacity

The following table (from NZS 4541) shows the minimum storage tank capacity required for hazard classifications

Hazard Classification	Primary Supply	Secondary Supply
Extra Light	60 Min x Design Flow	40 min x Design Flow
Ordinary	60 min x Design Flow	40 min x Design Flow
Extra High	See Table 6.1 in Standard	See Table 6.1 in Standard

Design Criteria

Each Hazard Classification sets down the water supply required based on area of operation and design density requirements for each specific area of operation

Early Suppression Fast Response: ESFR

Storage occupancies present a number of particular problems for sprinkler protection. There are several reasons why this should be so:

the vertical surfaces and natural flues presented by stored goods promote rapid fire spread

the sprinkler heads may be a long way above the fire and may take some time to operate

there is a good chance that the fire may be shielded from the spray

by the time water gets to the fire the heat release rate may be so great that the spray is ineffective

Installing in-rack sprinkler systems may solve these problems. These are highly effective but are seen as expensive in some instances and prone to mechanical damage from forklift trucks for example.

The problem was solved for certain types of storage by the development of the Early Suppression Fast Response sprinkler. The sprinkler relies on large diameter pipe work and a specially designed orifice that delivers a far greater density of water than a conventional sprinkler head. This density was determined by actual measurements on large storages. In addition the design of the deflector plate promotes the production of large drops preferentially which penetrate the plume and wet the fire at source. These sprinklers aim to suppress the fire, not just to control it, with the action of only 3 or 4 heads. They are of course fast response so that the water is delivered to the fire as rapidly as possible. The storage conditions suited to the use of these sprinklers are quite stringently defined.

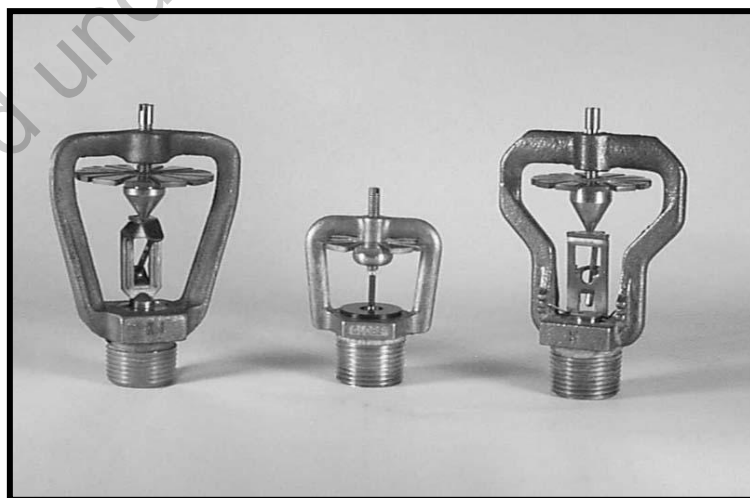

ESFR Heads

Water Mist

There is increasing interest in certain applications in the use of water mists or fog systems for extinguishing purposes. The water mist divides the spray up into very fine droplets by use of a high-pressure gas. Small droplets have a much higher surface area than large droplets, and so the droplets can evaporate more quickly and absorb heat more effectively. This suggests that less water could be used in tackling the fire, as less is likely to be wasted.

Such systems are used in ships and in applications such as tunnels where access for conventional firefighting is restricted.

Entrainment of water droplets

Large-scale experimental work on the suppression of fires in oil and gas wells has made use of fine water mists coupled with the natural tendency of the flame to entrain air. By introducing the mist droplets around the base of the flame they are naturally drawn into the flame by the entrainment process. Once in the flame the droplets are rapidly vaporised and heated to flame temperatures, removing heat in the process. Because of the way in which the droplets are drawn into the flame, the effectiveness of the cooling becomes much more efficient as so little is lost to the surroundings. The quantities of water used in such applications are much closer to the theoretical values calculated earlier.

Fire Brigade Systems - Fire Hydrant Systems for Buildings

Fire Hydrant

A building fire hydrant is provided for the Fire Service to reticulate fire fighting water.

Water is drained from the in-ground public water mains and pumped via the appliance into the system.

Building Pumps

Where Fire Service appliances are not capable of producing the pressure required at the outlet, building pumps are provided.

Pre Inlet Pressure

The pressure a Fire Service appliance can currently deliver to the inlet of the hydrant system is 1050 kpa. This is the pressure limitation of the single lugged instantaneous coupling.

Outlet Pressure

600 – 1200 kpa

Flow Rate

7.3 l/s per outlet.

Standard

NZS: 4510

Types of Systems

Dry System

System contains no water.

No longer allowed under standard.

Wet System

System filled with water and ancillary pumps as necessary to deliver required flows at outlets from mains. Does not require Fire Service appliance.

Charged System

System filled with water by small mains connection. Requires Fire Service appliance to deliver required flows.

Number of Outlets Required

Require an outlet within the building capable of reaching extremities of the building within a 50m arc.

Measurement of Arc

Taken from outlet on that floor if outlet within a protected lobby, or taken from the floor below, allowing for extra distance required to ascend stairs.

Protected Lobby

An enclosed part of the floor, having an area of 6m^2 or more.

- Must be directly accessible from stair
- Minimum fire resistance rating of 60/60/60

Fire Service Inlet

Within 18m of accessible position for fire appliance.

information

A waterproof book must be provided in the inlet housing with a diagram showing all:

- valves
- outlets
- pressure control devices
- pumps
- settings of all pressure reducing valves

Pumps

Manually started (after charging with water if necessary)

Manually stopped

Hydrant Requirement NZ 4510				
Hose Streams	Building	Ave floor area (Max) M ²	Outlets per floor	Max water flow l/s
2	Single storey	4900	1	14.6
4	Multiple storey	4900	1	29.3
8	9800	2	58.7	
10	14700	3	73.3	
12	19600	4	88	

Note: Pre-1998 flows and outputs will vary .