



File No. DOIA1718-0092

- 2 AUG 2017

Ms Jennifer Cooper
fyi-request-6225-00832d68@requests.fyi.org.nz

Dear Ms Cooper

Thank you for your email of 17 July 2017, requesting under the Official Information Act 1982, the following information:

Please provide a copy of the fire report and design approved in respect of the MultiProof Consent for Flaming Phoenix Entertainment Limited.

Attached to this response is a copy of the information you have requested and released to you in full.

Yours sincerely

John Gardiner
Manager, Determinations and Assurance
Building System Performance





ZIRKA CIRCUS

Job number: 1942 | 21/08/2013 | Issue 1

Released Under the
Official Information Act 1982

Issue	Date	Author	Status	Extent of Revision
1	21 AUGUST 2013	MEA DLS	BUILDING CONSENT	

Prepared by:



Mahesh Andhe

Fire Engineer

BE Hons, PGCert (Eitrx), ME (Fire)

Reviewed by:



Debbie Scott

Principal Fire Engineer

ME Dist. (Fire), PMSFPE, FIPENZ, CPEng



OnFire Consulting Limited

477 Alexandra Street, PO Box 226, Te Awamutu 3840, New Zealand

Phone: 07 870 6411 Fax: 07 870 6412

Email: info@onfire.co.nz; www.onfire.co.nz

Table of Contents

1	PURPOSE	5
2	FEB ACCEPTANCE	5
3	INTRODUCTION	6
4	BUILDING IMPORTANCE LEVEL AND RISK GROUPS	6
4.1.	BUILDING IMPORTANCE LEVEL	6
4.2.	RISK GROUPS	6
4.3.	OCCUPANT LOADS.....	7
5	FIRE SAFETY PRECAUTIONS	7
5.1	FIRE SAFETY PRECAUTIONS TO BE INSTALLED IN THE BUILDING:.....	7
6	MEANS OF ESCAPE	8
6.1	GENERAL	8
6.2	NO. OF ESCAPE ROUTES	8
6.3	WIDTH & HEIGHT OF ESCAPE ROUTES.....	8
6.4	DOORS – SWING AND LOCKING DEVICES.....	9
6.5	FIRE ESCAPE ROUTE SIGNAGE	9
6.5.1	<i>Fire Escape Route Signage Location</i>	9
6.5.2	<i>Fire Escape Route Signage Type and Illumination</i>	9
6.6	MISCELLANEOUS.....	9
7	DESIGN SCENARIO 1 FIRE BLOCKS EXIT	10
7.1	ESCAPE ROUTES.....	10
7.2	CAPACITY OF MEANS OF ESCAPE	10
8	DESIGN SCENARIO 2 UNKNOWN THREAT	10
8.1	DESIGN SCENARIO 2: FIRE IN NORMALLY UNOCCUPIED ROOM	10
9	DESIGN SCENARIO 3 CONCEALED SPACE	11
9.1	DESIGN SCENARIO 3: FIRE STARTS IN CONCEALED SPACE	11
10	DESIGN SCENARIO 4 SMOULDERING FIRE	11
10.1	DESIGN SCENARIO 4 SMOULDERING FIRE	11
11	DESIGN SCENARIO 5: HORIZONTAL FIRE SPREAD	11
11.1	BOUNDARY EXPOSURES.....	11
12	DESIGN SCENARIO 6: VERTICAL FIRE SPREAD	11
13	DESIGN SCENARIO 7: RAPID FIRE SPREAD INVOLVING INTERNAL SURFACE LININGS	11
13.1	INTERIOR SURFACE FINISHES, FLOOR COVERINGS AND SUSPENDED FABRICS:	11
14	DESIGN SCENARIO 8: FIREFIGHTING OPERATIONS	12
14.1	FIRE FIGHTING OPERATIONS	12
15	DESIGN SCENARIO 9: CHALLENGING FIRE	12

15.1	CAPACITY OF MEANS OF ESCAPE	12
15.2	TRAVEL DISTANCES	12
15.3	MODELLING CHALLENGING FIRE SCENARIOS USING B-RISK	12
15.4	MODELLING GEOMETRY TO DETERMINE ASET	13
15.5	ASET/RSET RESULTS CHALLENGING FIRE: LOCATION 1	14
15.6	ASET/RSET RESULTS CHALLENGING FIRE: LOCATION 2	16
16	DESIGN SCENARIO 10: ROBUSTNESS CHECK	16
17	STRUCTURAL REQUIREMENTS	16
18	D1: ACCESS ROUTES (AS APPLICABLE TO MEANS OF ESCAPE).....	17
19	COMPLIANCE SCHEDULE INFORMATION	17
20	CONCLUSION.....	17
21	APPENDIX 1 – NZFS ACCESS.....	18
22	APPENDIX 2: BCA CHECK SHEET FOR BUILDING ACT SECTION 46.....	19
23	APPENDIX 3 – COMPLIANCE SCHEDULE INFORMATION.....	20
24	APPENDIX 4 – B-RISK RESULTS – CF1	22
17.1.	B-RISK RESULTS – CF1.....	22
25	APPENDIX 5 – B-RISK RESULTS – CF2	47
18.1.	BRANZFIRE RESULTS – CF2	47
26	APPENDIX 6 - FIRE ENGINEERING BRIEF (FEB).....	72
27	APPENDIX 7 – DRAWINGS	73
28	APPENDIX 8 - CORRESPONDENCE EMAILS	74

1 Purpose

The purpose of this report is to show compliance with the New Zealand Building Code (NZBC) for Protection from Fire as required by the Building Act 2004 for an existing circus tent that travels the country throughout the year and is likely to be erected 50 weeks of the year. This fire engineering design is to be used for a multiproof application.

This report addresses the requirements of the Building Act 2004 only and does not address owners or tenants property protection unless specifically referenced. This report is specific to the building and client, it is not to be used by any third party and no responsibility is taken for any third party who uses this report.

To meet the mandatory requirements of the NZBC fire safety clauses C1 to C6 Protection from Fire, this report is based on the following:

- C/VM2 Verification Method: Framework for Fire Safety Design,
- F6/AS1 Visibility in Escape Routes, Third Edition 18 October 2007,
- F7/AS1 Warning Systems, Fourth Edition, 10 April 2012,
- F8/AS1 Signs, Second Edition, 10 April 2012 (as applicable to fire safety),

This Zirka circus tent is designed in accordance with the **Verification Method C/VM2**.

Issues that may arise under the Fire Safety and Evacuation Regulations 2006 should be discussed directly with the New Zealand Fire Service (NZFS).

This report does not examine any storage, ventilation or bunding requirements for hazardous substances as defined in the Hazardous Substances and New Organisms Act 1996 (HSNO) or Building Code Clause F3- Hazardous Substances and Processes, and in particular the Hazardous Substances (classes 1 to 5 controls) Regulations 2001. It is assumed that any hazardous substance not stored as required by the Regulations is in such small quantities as to have minimal effect on the fire load of the building. Building owners should contact an EPA Test Certifier for advice on compliance.

This fire engineering design is a performance document, specifically for Zirka circus tent only. The consultants whose documentation is required to incorporate the requirements of this fire engineering design are expected to have read this report, understood the implications as it affects their scope of work and have incorporated the relevant fire safety requirements into their drawings and specifications.

The fire design in this report does not meet the criteria specified in the Gazette Notice #49 of 3 May 2012 published by the Department of Building and Housing and therefore does not require submission to the NZFS Engineering Unit (DRU).

2 FEB Acceptance

The FEB has been reviewed by all of the stakeholders. The stakeholders have no significant reservations about any of the content and have accepted the FEB. The FEB documentation is attached in Section 26.

3 Introduction

This is an existing circus tent that travels the country throughout the year and is likely to be erected 50 weeks of the year. Given the need for multiple consents throughout the year a Multi-Proof consent through the Ministry of Business, Innovation and Employment (MBIE) is to be applied for. The details in this fire engineering design relate to the Code Clauses C1-C6. Other Code Clauses are to be dealt with by the applicant with MBIE.

The circus tent is in the process of purchasing new seating and the proposed number of seats is 690 which is based on this fire engineering design.

The existing circus tent is made of a fabric called Ferrari F702 "Big Top". Testing has been undertaken by AWTA for Baytex who are NZ's leading Tent and Marquee Manufacturer and the flammability index achieved was 5. The Fabric on this circus tent is clearly stamped and hallmarked by the manufacturer, showing that this is indeed the fabric used as per FEB attached in Section 26, Appendix 6.

This fire engineering design report, along with BCA check sheet, Compliance Schedule, B-Risk inputs/outputs (for CF1 and CF2), FEB documentation, drawings, Flammability Index Test sheet for the above mentioned fabric and correspondence emails at the rear of this FER report form the fire engineering documentation.

A site visit to the tent was undertaken on the 30th April when it was erected in Hamilton, and a FEB meeting was held on 22nd of May 2013.

4 Building Importance Level and Risk Groups

4.1. Building Importance Level

In accordance with Clause A3 of the Building Code the Importance Level of the circus tent has been classified as follows:

Importance Level	Description of Building Type	Specific Structure
IL 3	Buildings of a higher level of societal benefit or importance, or with higher levels of risk-significant factors to building occupants. These buildings have increased performance requirements because they may house large numbers of people, vulnerable populations, or occupants with other risk factors, or fulfil a role of increased importance to the local community or to society in general.	Buildings where more than 300 people congregate in 1 area

4.2. Risk Groups

Although C/VM2 does not specify Risk Groups per-se, they are applicable to some sections of the Verification Method:

Location	Risk Group	Acceptable Solution	Escape Height	No. of people
Circus Tent	CA	C/AS4	0m	690

4.3. Occupant Loads

The occupant loads for the tent are based upon the proposed seating. The new seating is proposed to allow 690 occupants in the arrangement shown in Appendix 1 of Fire Engineering Brief attached as Appendix 6 in Section 26 of this Fire Engineering Report.

5 Fire Safety Precautions

5.1 Fire Safety Precautions to be installed in the building:

As discussed in the FEB, visual detection would be the main form of detection should the fire occur in the circus ring. Manual alarms would then be activated by circus staff. Type 2 fire alarm systems will be installed in the circus tent with manual call points provided in sound box and backstage as discussed in FEB. The fire alarm panel is to be provided in the sound box and is to be interfaced with audio and normal lights and emergency lighting such that when the fire alarm is sounded then the audio and lights should turn "OFF" and the emergency lighting should turn "ON".

An Emergency lighting system is to be installed in the building as required by F6/AS1. The emergency lighting system is to highlight specified features such as: escape routes in excess of 20 m from the farthest point in the circus tent to the closest final exit. Also changes in direction, tripping hazards, stairs, ramps, entries into safe paths, etc. This report does not address Visibility in Escape Routes and it is therefore to be designed and detailed by an electrical engineer for compliance with clause F6 of the Building Code.

However, there is emergency lighting proposed by the client. The client wishes to have emergency lights (Flood lights) to be located on four king poles of the circus tent preferably not too high. The location and the type of these lights are as shown in the drawings attached as Appendix 7 in Section 27 of this fire engineering report.

Information in this report such as occupant load, escape routes and the location of EXIT signs will be required in order for the electrical consultant to design adequate illumination. Note also that any escape route marked on attached fire safety plans are not to be taken as 'specific escape routes' in terms of F6/AS1/1.3.2.

Engage the services of a suitably qualified person to design and install an emergency lighting system to comply with NZBC F6 Visibility in Escape Routes, Clause 1.2 and Clause 1.3. Emergency lightings shall be located in accordance with F6/AS1/1.2 and shall be located:

- (a) At every change of level in the building,
- (b) in any part of an escape route designed to serve more than 250 people,

Emergency lighting must be installed in the areas specified and must provide a direct illuminance of no less than (F6/AS1/1.3.1):

- Minimum 1 Lux in Escape Routes
- Minimum 1 Lux at every change of level or change of direction in an escape route
- Minimum 0.2 Lux everywhere else

Emergency lighting must be maintained for 30 minutes in the Zirka circus tent

The drawings in Section 27, Appendix 7 detail indicative locations of where emergency lighting would be required for compliance with F6/AS1.

6 Means of Escape

6.1 General

This circus tent only has open path escape routes and final exits and does not require any smoke lobbies or safe-path exitways.

The escape routes are to comply with NZBC Clause D1. Ramps, stairs, landings, handrails, doors, vision panels and openings are to comply with D1/AS1.

6.2 No. of Escape Routes

The actual numbers of escape routes provided are 4 (Main Entrance/ Exit 1, two side exits (Exit 2 and Exit 3) and a rear staff only exit (Exit 4)). Exit 4 has not been considered in the assessment as discussed in the FEB process. The open paths to Exit 1, 2 and 3 diverge at an angle no less than 90° and are separated by 27 m (≥ 20 m for >250 occupants) as per C/VM2 therefore complies with alternate escape route requirements of C/VM2.

6.3 Width & Height of Escape Routes

The following table details the minimum required widths of escape routes in the building.

Location	Horizontal Travel (mm)	Minimum door widths (mm)
All open paths which are not an accessible route	850	760
All open paths which are accessible routes	1200	760

The height of an escape route is to be a minimum of 2100mm; any doors are required to have a minimum clear height of 1955mm. (C/AS4/3.3.1).

The door widths in the Zirka circus tent are 3400 mm and the clear height of the doors is 1.8 m (As per FEB and the drawings attached in FEB, Section 26). The escape routes and the door widths in the Zirka circus tent comply with this requirement. (C/AS4/3.3.2).

6.4 Doors – swing and locking devices

Doors on escape routes are required to open in the direction of escape if there are more than 50 occupants using the doors. The doors in the circus tent are not traditional doors but are quickly openable tent flaps and hence comply with these requirements. The tent flap / egress doors are tied together via 'lacing'. They do have a knot in place at the bottom of the doors to ensure these doors are locked when the tent is unoccupied. The circus do have a procedure in place to ensure that the doors are unknotted (with lacing still in place) prior to the public occupying the tent. Once the knot is undone the flaps come open when pushed on the doors itself. Description regarding the opening of the tent flaps is attached in Section 28 in the correspondence emails.

6.5 Fire Escape Route Signage

6.5.1 Fire Escape Route Signage Location

Fire exit signage is to be installed throughout the building to indicate the escape routes and final exits in compliance with F8/AS1.

Escape route signs shall be located in accordance with F8/AS1/4.1: Escape routes shall be identified by exit signs which are clearly visible and shall be located:

- a) At each point in the open path where a door giving access to a final exit is not visible in normal use.
- b) To clearly indicate each door giving access to a final exit and
- c) To clearly identify the route of travel.

6.5.2 Fire Escape Route Signage Type and Illumination

Escape route signs (and final exit signs) are to be text or a pictogram or both. (F8/AS1/2.1.d).

Exit signs in escape routes shall be illuminated as required by NZBC Clause F6. (F8/AS1/4.5.1) The Exit sign shall be internally illuminated.

Exit signage's are internally illuminated and is currently provided at all the exits. These exist signs are to be turned on prior to the starting of every performance. Additional required exit sign locations is as shown in the drawings attached as Appendix 7 in Section 27

6.6 Miscellaneous

Exit doors and escape routes are to remain clear at all times. Escape routes shall not be used for storage of goods, solid waste or solid waste containers.

Please note that the escape route widths specified in this report are the minimum required widths for fire safety only and do not specify widths that may be needed for compliance with Clause D1 (Access Routes). It is also noted that other escape route features as required by Clause D1 and Clause F4 (Safety from Falling) are not addressed by this report.

7 Design Scenario 1 Fire Blocks Exit

7.1 Escape Routes

There are three designated final exits and the escape routes to which diverge at an angle no less than 90° and are separated by 27 m (≥ 20 m for >250 occupants) as per C/VM2 therefore complies with alternate escape route requirements of C/VM2.

The capacity of means of escape is as detailed below as the circus tent is unsprinklered

7.2 Capacity of Means of Escape

The following table details the actual egress capacity from the building (and each area) in accordance with C/AS4/3.3.2. Although C/VM2 is used for analysis the capacity calculation shows the available egress.

Component	Door Width (mm)	Egress Capacity (# people)
Main entrance/Exit 1	3400	484
Exit 2	3400	484
Exit 3	3400	484
TOTAL		1452
Deduct unavailable exit		- 484
Total available width		968

Note:

- (1) In accordance with C/AS4/3.3.2e where the firecell is unsprinklered it is necessary to provide extra width to allow for the possibility that one escape route may be unusable. Also it is to be noted here that the emergency exit at the back of stage is not used in the analysis.

The egress capacity as shown on the drawings is sufficient for the design occupant load of 690 people in the building.

8 Design Scenario 2 Unknown Threat

8.1 Design Scenario 2: Fire in normally unoccupied room

This scenario is not applicable as there is no unoccupied space in the circus tent. However there is a challenging fire scenario modelled underneath the seating and is documented as design fire scenario 2 in the Challenging Fire section (Please refer to Section 15 of this fire engineering report).

9 Design Scenario 3 Concealed Space

9.1 Design Scenario 3: Fire starts in concealed space

This scenario is not applicable as there is no concealed space in the circus tent.

10 Design Scenario 4 Smouldering Fire

10.1 Design Scenario 4 Smouldering Fire

This scenario is not applicable as there are no sleeping risk group occupants in the circus tent.

11 Design Scenario 5: Horizontal Fire Spread

11.1 Boundary Exposures

For the circus tent to have 100% unprotected areas in the external walls, the tent shall be located more than 10 m away from every neighbouring boundary wherever erected as per C/VM2/A2.4 for a FLED = 800 MJ/m², Height of enclosing rectangle = 4m and Width of the firecell = >20m.

Wall Elevation	Distance to Boundary (m)	Firecell Width (m)	Unprotected Area (%)	
			Allowed	Actual
North	>10m	>20m	100%	100%
South	>10m	>20m	100%	100%
East	>10m	>20m	100%	100%
West	>10m	>20m	100%	100%

The circus tent management must ensure that the tent is located further than 10 m from every neighbouring boundary. This is to be calculated by each BCA as per their approval process.

12 Design Scenario 6: Vertical Fire Spread

As the building is <10m high to the top of the circus tent wall, vertical fire spread is not applicable

13 Design Scenario 7: Rapid Fire Spread Involving Internal Surface Linings

13.1 Interior Surface Finishes, Floor Coverings and Suspended Fabrics:

The existing circus tent is made of a fabric called Ferrari F702 "Big Top". Testing has been undertaken by AWTA for Baytex who are NZ's leading Tent and Marquee Manufacturer and the flammability index

achieved was 5 (as per FEB). The Fabric on this circus tent is clearly stamped and hallmarked by the manufacturer, showing that this is indeed the fabric used, therefore satisfies the surface finish requirements of the NZBC. The testing certificate is provided in Appendix 1 of FEB attached in Section 26 as Appendix 6

There are no foamed plastics in the circus tent and the wall and the ceiling surface finish requirements do not apply to the circus tent as it is a membrane structure.

14 Design Scenario 8: Firefighting Operations

14.1 Fire Fighting Operations

The circus tent is expected to be located in public parks and other public places where NZFS shall have direct access from public streets to enable the requirements for fire service access are complied with. This is to be checked by each BCA as a part of their approval process.

15 Design Scenario 9: Challenging Fire

15.1 Capacity of Means of Escape

The following table details the actual egress widths for crowd areas in the tent which are used in the ASET/RSET calculations:

Circus Tent	Door	Door Width (mm)
Ground floor	Main entrance/exit 1	3400
	Exit 2	3400
	Exit 3	3400

15.2 Travel Distances

The worst case travel distance for the occupants in the Zirka circus tent is 36 m (18m along bleachers + 18 m horizontal travel) which is used for ASET/RSET calculations.

15.3 Modelling challenging fire scenarios using B-risk

Design Fire 1: Fire in Circus Ring

- C/VM2 mode used in B-Risk modelling.
- All the escape doors from the Circus ring are closed until evacuation begins;
- The circus ring has been modeled with an aspect ratio of 1:5 using the actual area of 6732 m²;
- This gives a width and length of 31 m with a minimum stud height of 4 m and maximum stud height of 10 m.

- All the gaps (Kingpoles, Cupola, Seams and sidewalls) are modeled as one vent to the outside with a total area of 4 m^2 ; (details of gaps are provided in vent / leakage drawings attached as Appendix 2 of FEB which is in 26 of this fire report)
- The door openings (1.7 m (wide) x 1.8 m (height)) and the triangular openings (1.16 m (wide) x 1.16 (height) = 1.35 m^2) above doors are modeled as half open for smoke ventilation ;
- Fast t^2 fire modelled, as per C/VM2 Table 2.1;
- FLED 800 MJ/m^2 , HRRPUA 250 kW/m^2
- Doors are modeled to open at 140 seconds (110 seconds (500 kW fire size) + 30 seconds (notification time)) as per C/VM2 Table 3.3 .

The volume of the tent modeled is 6731 m^3 which is less than the actual volume of 8013 m^3 .

Design Fire 2: Fire underneath seating

- As per Design Fire 1 except for the location of fire origin being the space underneath the seating.

15.4 Modelling geometry to determine ASET

The model of the building was divided into two different rooms connected to each other via vent opening. Leakages were modelled as separate wall vents connecting to outside.

Below is the screenshot of the model in B-Risk. Room 1 represents the circus ring and Room 2 represents area underneath seating connecting to each other via vent. FED_{CO} , $FED_{THERMAL}$ and Visibility were assessed. The height above the floor at which tenability is assessed is 2.0 m. Figures below show the schematic representation of the model used for the B-Risk simulations. All doors are assumed closed until evacuation which is deemed to commence after the fire reaches 500 kW.

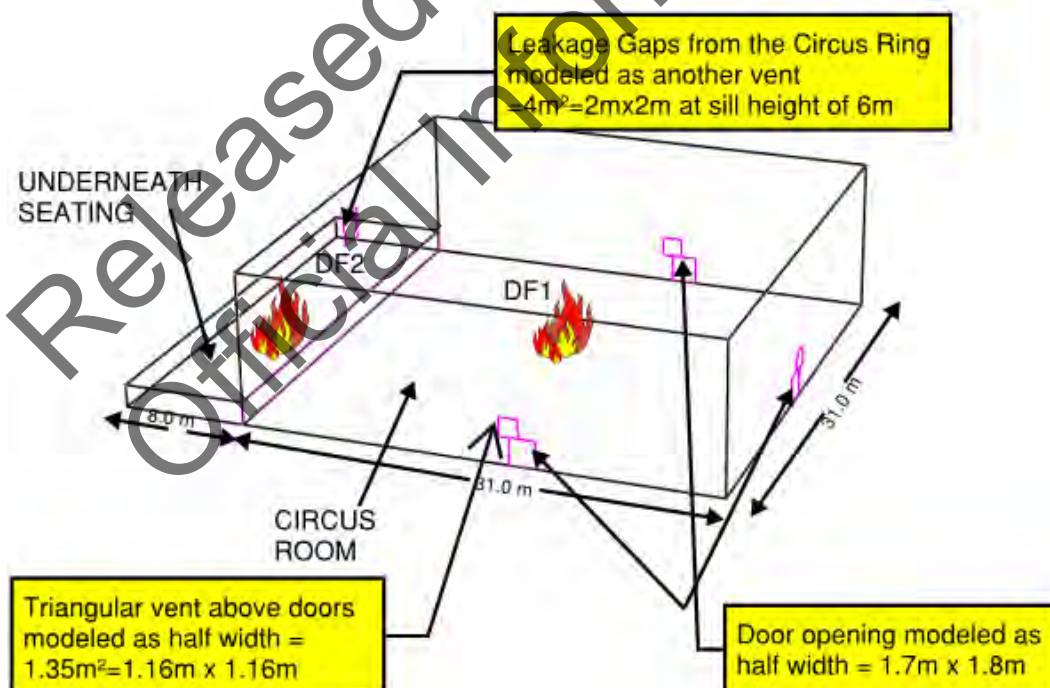

15.5 ASET/RSET Results Challenging Fire: Location 1

Design Fire 1: Fire within Circus Ring

The RSET is determined from the following equation:

$$\text{RSET} = (T_D + T_N + T_{PRE}) + (T_{TRAV} \text{ OR } T_{FLOW})$$

Where:

T_d = time to detection of fire = 110 seconds, (visual detection) As per C/VM2 Table 3.3 for spaces within building which have only focused activities (eg, cinemas, theatres and stadiums) occupants are assumed to start evacuation travel when fire in their space reaches 500 kw. This value is 110 seconds

T_n = Notification time applies and this value is 30 seconds as per C/VM2 3.2.2.

T_{pre} = time from notification until occupants commence evacuation=0 seconds as discussed in FEB.

The travel time is governed by either the time taken to travel to the doorway or the time taken for all the occupants to flow through the doorway (whichever is greater).

T_{trav} = occupant travel time to move to a place of safety. Calculated knowing the travel distance and applying the travel speed as determined.

The analysis is for 50% of the occupants i.e 345 out of 690 using the main exit 1 for escape as it is likely that the occupants would like to move to the main exit where they would have originally come in from. The following tables summarises the RSET calculations for the building for this scenario.

		Enclosure of origin Circus Ring (Room 1)	
Travel Time			
Horizontal Travel			
Area		344	m ²
No. of Occupants		345 (50% using main exit 1 for escape)	people
Density of Occupants in space	D	n/a (as 690 people are expected to occupy the space as per information supplied from the client)	people/m ²
k factor	k	1.4	
a factor	A	0.266	
Travel Speed S = k-akD		1.139	m/s
Travel Speed along bleachers		0.85	
Max Travel Speed		1.2	m/s
Horizontal Travel Distance	L_{trav}	18	m
Travel Distance along bleachers	L	18	
$T_{trav} = L_{trav}/S$	T_{trav}	(1)	16 seconds

$T_{trav} = L_{trav}/S$	T_{trav}	(1)	22	seconds
Flow Time				
Occupant Density at door	D		1.9	people/m ²
Width	W		3.4	m
Boundary Layer Width			2 x 0.15	m
Effective Width	W_e		3.1	m
$F_c = (1-aD)kDW_e$			1.67 person/s VM2 (if $F_c > 100$, 100 persons/min max cap double leaf)	People/sec
Queuing Time	t_q	(2)	76	seconds
Evacuation time (greater of travel or flow)			76	seconds
Detection time	t_d		110	seconds
Alarm notification time	t_n		30	seconds
Occupant Pre-movement time	t_{pre}		0	seconds
RSET	RSET		216	seconds

ASET:

Results from B-Risk Simulation are as below:

Visibility in Circus Ring (Room 1) at 2 m above floor reduces to less than 10 m at 410 seconds.

FED (CO) in Circus Ring (Room 1) exceeded 0.3 at 775 seconds

FED (THERMAL) in Circus Ring (Room 1) exceeded 0.3 at 490 seconds.

The following Table summarises the B-Risk modelling results for this fire scenario

	Enclosure of origin (Room 1)	
B-Risk Results		
ASET (Visibility < 10m)¹	<410	seconds

Note:

- (1) Visibility reduces to less than 10 m in Room 1 at 430 seconds.

ASET/RSET:

The following Table summarises the ASET/RSET modelling results for this fire scenario:

	Enclosure of origin (Room 1)	
ASET	<410	seconds
RSET	216	seconds

The ASET/RSET calculations show that the means of escape for the occupants of the building comply with the NZBC for a challenging fire in this location.

15.6 ASET/RSET Results Challenging Fire: Location 2

Design Fire 2: Fire underneath seating

The RSET calculation is exactly same as performed for Challenging fire location 1, since the occupants are only in Room 1 (Circus Ring). Therefore the ASET is 184 seconds.

ASET:

Results from B-Risk Simulation are as below:

Visibility in Circus Ring (Room 1) at 2 m above floor reduces to less than 10 m at 360 seconds.

FED (CO) in Circus Ring (Room 1) exceeded 0.3 at 765 seconds

FED (THERMAL) in Circus Ring (Room 1) exceeded 0.3 at 595 seconds.

The following Table summarises the B-Risk modelling results for this fire scenario:

	Remote from origin (Room 1)	
B-Risk Results		
ASET (Visibility < 10m) ¹	<360	seconds

Note:

- (1) Visibility reduces to less than 10 m in Room 1 at 390 seconds with fire location underneath the seating.

ASET/RSET:

The following Table summarises the ASET/RSET modelling results for this fire scenario:

	Remote from origin (Room 1)	
ASET	<360	seconds
RSET	216	seconds

The ASET/RSET calculations show that the means of escape for the occupants of the building comply with the NZBC for a challenging fire in this location.

16 Design Scenario 10: Robustness Check

There are no key fire safety systems to fail, therefore this scenario is not applicable.

17 Structural Requirements

Structural requirements need not be assessed for Zirka circus tent provided the tent is located >10 m from the boundary as detailed in Section 11 of this Fire report .

18 D1: ACCESS ROUTES (As Applicable to Means of Escape)

Accessible routes to have signs (symbols of access ♿) complying with NZBC F8.

The clear width of an accessible route shall be no less than 1200 mm.

19 Compliance Schedule Information

There are 'Specified Systems' identified by this fire engineering design which would be required to be listed on a Compliance Schedule and is attached in Section 23 as Appendix 3.

20 Conclusion

This Verification Method analysis shows that the proposed Zirka Circus tent will achieve compliance with the NZ Building Code Clauses C1 – C6 for Protection from Fire as required by the NZ Building Act.

This is subject to the assumptions and requirements being met within this report. The main requirements of the report are summarised below however the report needs to be read in its entirety to ensure all requirements are met.

- 1) Emergency lighting is to be installed in the building as required by F6/AS1. However, there is emergency lighting proposed by the client. The client wishes to have emergency lights (Flood lights) to be located on four king poles of the circus tent preferably not too high. The location and the type of these lights are as shown in the drawings attached as Appendix 7 in Section 27 of this fire engineering report.
- 2) All exit door locking devices if any other than the openable tent flaps should be clearly visible, located where such a device would normally be expected, designed to be easily operated without a key or other security device, and allow the door to open in the normal manner.
- 3) Fire exit signage shall be erected throughout the building in compliance with F8/AS1. Exit signage shall be internally illuminated as part of the emergency lighting system.
- 4) NZFS requirements are provided in Section 21 of this report.

21 APPENDIX 1 – NZFS Access

Part 6: Firefighting

CONTENTS

- 6.1 Fire service vehicular access
- 6.2 Information for firefighters
- 6.3 Access within the building for firefighting and rescue operations
- 6.4 Firefighting facilities

6.1 Fire Service vehicular access

6.1.1 If *buildings* are located remotely from the street boundaries of a property, pavements situated on the property and likely to be used for vehicular access by *fire* appliances shall:

- a) Be able to withstand a laden weight of up to 25 tonnes with an axle load of 8 tonnes or have a load-bearing capacity of no less than the public roadway serving the property, whichever is the lower, and
- b) Be trafficable in all weathers, and
- c) Have a minimum width of 4.0 m, and
- d) Provide a clear passageway of no less than 3.5 m in width and 4.0 m in height at site entrances, internal entrances and between *buildings*, and
- e) Provide access to a *hard-standing* within 20 m of:
 - i) An entrance to the *building*, and
 - ii) Any inlets to fire sprinkler or *building* fire hydrant systems.

Comment:

Access to *buildings* for *fire* appliances will be generally via public streets, but provision is needed on large, multi-*building* sites to enable appliances to reach any *building*.

6.1.2 THIS PARAGRAPH DELIBERATELY LEFT BLANK

6.2 Information for firefighters

6.2.1 If *fire* detection and alarm systems or sprinkler systems are installed, the control panel shall be located in a position close to the Fire Service attendance point and in accordance with NZS 4512, NZS 4515 and NZS 4541 as appropriate.

6.2.2 If *hazardous substances* are present in the *building* warning signage in accordance with NZBC F8 shall be displayed.



22 Appendix 2: BCA Check sheet for Building Act Section 46

The following assessment is carried out in terms of Gazette Notice #49 of 3 May 2012 published by the Department of Building and Housing to determine whether the BCA is required to forward a copy of this fire engineering to the NZFS Engineering Unit (DRU) for comment:

Clause			✓	X	Yes/No	
A	B	C	D	E	F	G
1		Evacuation Scheme in terms of Section 21A of Fire Service Act 1975				
	a	Gathering of 100 or more persons:	✓			
	b	Employment facilities for 10 or more persons:	✓			
	c	Accommodation for more than 5 persons (other than in 3 or fewer household units):		x		
	d	Hazardous substances present in quantities exceeding the prescribed minimum amounts:		x		
	e	Early childhood facilities (except in household):		x		
	f	Nursing, medical, or geriatric care(except in household):		x		
	g	Specialised care for persons with disabilities (except in household):		x		
	h	Accommodation for persons under lawful detention (except in home or community detention,		x		
		Clause 1 (Section 21A of Fire Service Act 1975) applies?			Yes	
2	a	Compliance with Building Code Clauses established by Compliance Document?				
		Protection from Fire: C/AS1, or C/AS2, or C/AS3 or C/AS4, or C/AS5, or C/AS6, or C/AS7, or C/VM1, or C/VM2	✓			
		Access Routes: D1/AS1	✓			
		Visibility in Escape Routes: F6/AS1	✓			
		Signs: F8	✓			
		Clause 2(a) applies?			No	
	b	Modification or waiver of Clauses C1-6, D1, F6 or F8 under Section 67 of the Building Act 2004?			No	
	c	Alteration or change of use affects fire safety system (including Specified System) except minor work?			No	
		Clause 2(b or c) apply?			No	
3		Clause 1 does not apply to: a) Single Household units, b) Household units fire cells and individual egress, c) Internal fit-out – unless fit-out is change of use, d) Outbuildings or ancillary buildings				
		Any Clause 3 triggers?			No	
		Are there at least 2 applicable items from column F? If yes then the BCA is obliged to forward the building consent to the DRU				No

The BCA is not required to forward a copy of this fire engineering to the NZFS Engineering Unit (DRU) for comment.

23 APPENDIX 3 – Compliance Schedule Information

The list of 'Specified Systems' below are for this building as identified by this fire engineering design. The Specified Systems identified below are not a comprehensive list of systems pertaining to the building. Please ensure that a comprehensive check of all possible systems is carried out when completing the Compliance Schedule.

The extent of coverage of the specified systems and where appropriate their location is identified on the attached plan. This should be included with the compliance schedule for the building.

SS	Specified System	Performance Standard	Maintenance	Inspections	New	Modify	List on CS
2	Automatic or Manual emergency warning systems for fire or other dangers Type 2 Manual call point system	NZBC: F7 Modified as discussed in FEB		By IQP: Every time whenever the circus tent is erected in a new place Monthly: In accordance with NZS 4512 Paragraph 602. Yearly: In accordance with NZS 4512 Paragraph 603.			✓
4	Emergency lighting systems Including illuminated signs	NZBC: F6, F8 AS 2293.3: 2005 (<i>Emergency escape lighting and exit signs for buildings - Emergency escape luminaires and exit signs</i>) (Existing NZS 6742)	In accordance with: AS/NZS 2293.2:1995 Section 3	By IQP Six monthly: In accordance with Paragraph 3.2 and Appendix B AS/NZS 2293.2 Yearly: In accordance with Paragraph 3.3 AS/NZS 2293.2			✓
15	Any or all of the following systems and features, so long as they form part of a building's means of escape from fire, and so long as those means also contain any or all of the systems or features specified in clauses 1 to 6, 9, and 13: Performance standard = NZBC:C1 – C6, F7, F8 as appropriate						
15 (2)	Final exits Details: Designated final exit doors	NZBC:C1 – C6 Fire Safety and Evacuation of Building Regulations 1992 Compliance Schedule Handbook 2007 All final exit doors to be free of obstructions both sides of the door and not to be locked or barred. Any panic furniture or simple fastenings should operate freely to release door. Full opening of door width is required.	Fire Safety and Evacuation of Building Regulations 1992 Compliance Schedule Handbook 2007 Maintained in a safe condition: free from obstructions, locking, blocking, barring, storage of combustibles and ease of opening at the final exit.	Daily inspections by owner for crowd type occupancies Monthly inspections for all other occupancies with annual inspection and maintenance by IQP By owner/Occupier Daily: Check doors are not locked blocked or barred. Weekly: As daily plus ensure routes to final exits do not contain combustibles and any fastenings open easily and door swings to full width of opening. By IQP Yearly: As above, complete report to owner and complete required forms.			✓

15 (4)	Signs for communicating information intended to facilitate evacuation	NZBC:F8 Signs will be visible under all foreseeable conditions including interruption of mains power.	Immediate replacement or refurbishment of signs if missing, incorrect or illegible.	Daily inspections by owner for crowd type occupancies Monthly inspections for all other occupancies with annual inspection and maintenance by IQP By owner/occupier Monthly: Ensure signs in place where required, they are legible and clean and are illuminated. Record in log book. By IQP. Yearly: As per monthly and complete report and required forms.			✓
-----------	---	--	---	--	--	--	---

Released Under the
Official Information Act 1982

24 APPENDIX 4 – B-Risk RESULTS – CF1**17.1. B-Risk Results – CF1****Design Fire 1: Fire in Circus ring**

Tuesday, August 20, 2013, 04:16 PM
 B-RISK Fire Simulator and Design Fire Tool (Ver 2013.12)

Input Filename : input1.xml
 Base File : C:\Users\Owner\Documents\B-RISK\riskdata\basemodel_Zirka_Circus\basemodel_Zirka_Circus.xml

User Mode : C/VM2

Zirka Circus

=====
 Description of Rooms
 =====

Room 1 : Circus Room

Room Length (m) =	31.00
Room Width (m) =	31.00
Maximum Room Height (m) =	10.00
Minimum Room Height (m) =	4.00
Floor Elevation (m) =	0.000
Absolute X Position (m) =	0.000
Absolute Y Position (m) =	0.000
Room 1 has a sloping ceiling.	
Shape Factor (Af/H^2) =	9.6
Wall Surface is steel (mild)	
Wall Density (kg/m3) =	7850.0
Wall Conductivity (W/m.K) =	45.800
Wall Specific Heat (J/kg.K) =	460
Wall Emissivity =	0.90
Wall Thickness (mm) =	3.0
Ceiling Surface is steel (mild)	
Ceiling Density (kg/m3) =	7850.0
Ceiling Conductivity (W/m.K) =	45.800
Ceiling Specific Heat (J/kg.K) =	460
Ceiling Emissivity =	0.90
Ceiling Thickness (mm) =	3.0
Floor Surface is concrete	
Floor Density (kg/m3) =	2300.0
Floor Conductivity (W/m.K) =	1.200
Floor Specific Heat (J/kg.K) =	880
Floor Emissivity =	0.50
Floor Thickness (mm) =	100.0

Room 2 : Bleachers

Room Length (m) =	31.00
Room Width (m) =	8.00
Maximum Room Height (m) =	1.50
Minimum Room Height (m) =	1.50
Floor Elevation (m) =	0.000
Absolute X Position (m) =	0.000
Absolute Y Position (m) =	31.000
Room 2 has a flat ceiling.	
Shape Factor (Af/H^2) =	110.2
Wall Surface is steel (mild)	
Wall Density (kg/m3) =	7850.0
Wall Conductivity (W/m.K) =	45.800
Wall Specific Heat (J/kg.K) =	460
Wall Emissivity =	0.90
Wall Thickness (mm) =	3.0

Ceiling Surface is steel (mild)
 Ceiling Density (kg/m³) = 7850.0
 Ceiling Conductivity (W/m.K) = 45.800
 Ceiling Specific Heat (J/kg.K) = 460
 Ceiling Emissivity = 0.90
 Ceiling Thickness (mm) = 3.0

Floor Surface is concrete
 Floor Density (kg/m³) = 2300.0
 Floor Conductivity (W/m.K) = 1.200
 Floor Specific Heat (J/kg.K) = 880
 Floor Emissivity = 0.50
 Floor Thickness = (mm) 100.0

=====

Wall Vents

=====

Vent 1 : Vent above front entran
 From room 1 to 3
 Front face of room 1
 Offset (m) = 14.870
 Vent Width (m) = 1.160
 Vent Height (m) = 1.160
 Vent Sill Height (m) = 1.800
 Vent Soffit Height (m) = 2.960
 Opening Time (sec) = 110
 Closing Time (sec) = 0
 Flow Coefficient (sec) = 0.680

Vent 2 : Vent above right door
 From room 1 to 3
 Right face of room 1
 Offset (m) = 12.900
 Vent Width (m) = 1.160
 Vent Height (m) = 1.160
 Vent Sill Height (m) = 1.800
 Vent Soffit Height (m) = 2.960
 Opening Time (sec) = 110
 Closing Time (sec) = 0
 Flow Coefficient (sec) = 0.680

Vent 3 : Vent above left door
 From room 1 to 3
 Left face of room 1
 Offset (m) = 12.900
 Vent Width (m) = 1.160
 Vent Height (m) = 1.160
 Vent Sill Height (m) = 1.800
 Vent Soffit Height (m) = 2.960
 Opening Time (sec) = 110
 Closing Time (sec) = 0
 Flow Coefficient (sec) = 0.680

Vent 4 : Door opening from entra
 From room 1 to 3
 Front face of room 1
 Offset (m) = 13.800
 Vent Width (m) = 1.700
 Vent Height (m) = 1.800
 Vent Sill Height (m) = 0.000
 Vent Soffit Height (m) = 1.800
 Opening Time (sec) = 110
 Closing Time (sec) = 0
 Flow Coefficient (sec) = 0.680

Vent 5 : Door opening Right face
 From room 1 to 3
 Right face of room 1
 Offset (m) = 11.800
 Vent Width (m) = 1.700
 Vent Height (m) = 1.800

Vent Sill Height (m) =	0.000
Vent Soffit Height (m) =	1.800
Opening Time (sec) =	110
Closing Time (sec) =	0
Flow Coefficient (sec) =	0.680

Vent 6 : Door Opening left face

From room 1 to 3	
Left face of room 1	
Offset (m) =	11.800
Vent Width (m) =	1.700
Vent Height (m) =	1.800
Vent Sill Height (m) =	0.000
Vent Soffit Height (m) =	1.800
Opening Time (sec) =	110
Closing Time (sec) =	0
Flow Coefficient (sec) =	0.680

Vent 7 : Bleachers height

From room 1 to 2	
Rear face of room 1	
Offset (m) =	0.000
Vent Width (m) =	31.000
Vent Height (m) =	1.500
Vent Sill Height (m) =	0.000
Vent Soffit Height (m) =	1.500
Opening Time (sec) =	0
Closing Time (sec) =	0
Flow Coefficient (sec) =	0.680
Vent Type is 3D adhered spill plume	
Balcony Width (m) =	0.000
Downstand Depth (m) =	8.500

Vent 8 : ceiling vent

From room 1 to 3	
Rear face of room 1	
Offset (m) =	15.500
Vent Width (m) =	2.000
Vent Height (m) =	2.000
Vent Sill Height (m) =	6.000
Vent Soffit Height (m) =	8.000
Opening Time (sec) =	0
Closing Time (sec) =	0
Flow Coefficient (sec) =	0.680

=====
Ceiling/Floor Vents
==========
Ambient Conditions
=====

Interior Temp (C) =	21.0
Exterior Temp (C) =	18.0
Relative Humidity (%) =	50

=====
Tenability Parameters
=====

Monitoring Height for Visibility and FED (m) =	2.00
Asphyxiant gas model =	FED(CO) C/VM2
Visibility calculations assume:	reflective signs
Egress path segments for FED calculations	
1. Start Time (sec)	0
1. End Time (sec)	600
1. Room	1
2. Start Time (sec)	600
2. End Time (sec)	900
2. Room	1
3. Start Time (sec)	900
3. End Time (sec)	1200
3. Room	1

```
=====
Sprinkler / Detector Parameters
=====
```

```

Ceiling Jet model used is NIST JET.
Sprinkler System Reliability          1.000
Sprinkler Probability of Suppression  1.000
Sprinkler Cooling Coefficient         1.000
=====
```

```
=====
Smoke Detector Parameters
=====
```

```

Smoke Detection System Reliability    1.000
=====
```

```
=====
Mechanical Ventilation (to/from outside)
=====
```

```

Mechanical Ventilation not installed.
Mech ventilation system reliability    1.000
=====
```

```
=====
Description of the Fire
=====
```

```

CO Yield pre-flashover(g/g) =          0.040
CO Yield post-flashover(g/g) =         0.400
Soot Yield pre-flashover(g/g) =        0.070
Soot Yield post-flashover(g/g) =       0.140
Flame Emission Coefficient (1/m) =     1.000
Fuel - Carbon Moles                   1.000
Fuel - Hydrogen Moles                 2.000
Fuel - Oxygen Moles                   0.500
Fuel - Nitrogen Moles                 0.000
=====
```

Burning objects are manually positioned in room.

```

Burning Object No 1
Fire
=====
```

```

Located in Room                       1
Energy Yield (kJ/g) =                 20.0
CO2 Yield (kg/kg fuel) =              1.500
HCN Yield (kg/kg fuel) =              0.000
H2O Yield (kg/kg fuel) =              0.818
Heat Release Rate Per Unit Area (kW/m2) = 250.0
Radiant Loss Fraction =               0.35
Fire Elevation (m) =                  0.300
Fire Object Length (m) =              0.300
Fire Object Width (m) =               0.300
Fire Object Height (m) =              0.000
Location, X-coordinate (m) =          15.500
Location, Y-coordinate (m) =          15.500
Fire Location (for entrainment) =     centre
Plume behaviour is undisturbed

Alpha T2 growth coefficient =         0.0469
Peak HRR (kW) =                      20000
=====
```

```
=====
Postflashover Inputs
=====
```

Postflashover model is OFF.

```
=====
Results from Fire Simulation
=====
```

```

0 min   00 sec
        (0 sec)
                Room 1   Room 2   Outside
Layer (m)          9.908   1.500
Upper Temp (C)    21.0    21.0
=====
```

Lower Temp (C)	21.0	21.0
HRR (kW)	0.0	0.0
Visibility (m) at 2m	20+	20+

FED gases on egress path = 0.000
 FED thermal on egress path = 0.000

0 min	10 sec (10 sec)	Room 1	Room 2	Outside
	Layer (m)	9.468	1.500	
	Upper Temp (C)	21.3	20.9	
	Lower Temp (C)	21.0	20.9	
	HRR (kW)	4.7	0.0	
	Visibility (m) at 2m	20+	20+	

FED gases on egress path = 0.000
 FED thermal on egress path = 0.000

0 min	20 sec (20 sec)	Room 1	Room 2	Outside
	Layer (m)	9.081	1.500	
	Upper Temp (C)	21.9	20.9	
	Lower Temp (C)	21.0	20.9	
	HRR (kW)	18.8	0.0	
	Visibility (m) at 2m	20+	20+	

FED gases on egress path = 0.000
 FED thermal on egress path = 0.000

0 min	30 sec (30 sec)	Room 1	Room 2	Outside
	Layer (m)	8.735	1.500	
	Upper Temp (C)	22.5	20.8	
	Lower Temp (C)	21.0	20.8	
	HRR (kW)	42.2	0.0	
	Visibility (m) at 2m	20+	20+	

FED gases on egress path = 0.000
 FED thermal on egress path = 0.000

0 min	40 sec (40 sec)	Room 1	Room 2	Outside
	Layer (m)	8.418	1.500	
	Upper Temp (C)	23.3	20.8	
	Lower Temp (C)	21.0	20.8	
	HRR (kW)	75.0	0.0	
	Visibility (m) at 2m	20+	20+	

FED gases on egress path = 0.000
 FED thermal on egress path = 0.000

0 min	50 sec (50 sec)	Room 1	Room 2	Outside
	Layer (m)	8.121	1.500	
	Upper Temp (C)	24.2	20.8	
	Lower Temp (C)	21.0	20.8	
	HRR (kW)	117.3	0.0	
	Visibility (m) at 2m	20+	20+	

FED gases on egress path = 0.000
 FED thermal on egress path = 0.001

1 min	00 sec (60 sec)	Room 1	Room 2	Outside
	Layer (m)	7.841	1.500	
	Upper Temp (C)	25.1	20.8	

Lower Temp (C)	21.0	20.8
HRR (kW)	168.8	0.0
Visibility (m) at 2m	20+	20+

FED gases on egress path = 0.000
 FED thermal on egress path = 0.001

1 min	10 sec (70 sec)	Room 1	Room 2	Outside
	Layer (m)	7.578	1.500	
	Upper Temp (C)	26.1	20.8	
	Lower Temp (C)	21.0	20.8	
	HRR (kW)	229.8	0.0	
	Visibility (m) at 2m	20+	20+	

FED gases on egress path = 0.000
 FED thermal on egress path = 0.001

1 min	20 sec (80 sec)	Room 1	Room 2	Outside
	Layer (m)	7.329	1.500	
	Upper Temp (C)	27.2	20.7	
	Lower Temp (C)	21.0	20.7	
	HRR (kW)	300.2	0.0	
	Visibility (m) at 2m	20+	20+	

FED gases on egress path = 0.000
 FED thermal on egress path = 0.001

1 min	30 sec (90 sec)	Room 1	Room 2	Outside
	Layer (m)	7.092	1.500	
	Upper Temp (C)	26.3	20.7	
	Lower Temp (C)	21.0	20.7	
	HRR (kW)	379.9	0.0	
	Visibility (m) at 2m	20+	20+	

FED gases on egress path = 0.000
 FED thermal on egress path = 0.001

1 min	40 sec (100 sec)	Room 1	Room 2	Outside
	Layer (m)	6.866	1.500	
	Upper Temp (C)	29.5	20.7	
	Lower Temp (C)	21.0	20.7	
	HRR (kW)	469.0	0.0	
	Visibility (m) at 2m	20+	20+	

FED gases on egress path = 0.000
 FED thermal on egress path = 0.001

1 min	50 sec (110 sec)	Room 1	Room 2	Outside
	Layer (m)	6.650	1.500	
	Upper Temp (C)	30.6	20.7	
	Lower Temp (C)	21.0	20.7	
	HRR (kW)	567.5	0.0	
	Visibility (m) at 2m	20+	20+	

FED gases on egress path = 0.000
 FED thermal on egress path = 0.001

2 min	00 sec (120 sec)	Room 1	Room 2	Outside
	Layer (m)	6.444	1.500	
	Upper Temp (C)	31.8	20.7	

Lower Temp (C)	21.0	20.7
HRR (kW)	675.4	0.0
Visibility (m) at 2m	20+	20+

FED gases on egress path = 0.000
 FED thermal on egress path = 0.001

2 min	10 sec (130 sec)	Room 1	Room 2	Outside
	Layer (m)	6.260	1.500	
	Upper Temp (C)	33.1	20.6	
	Lower Temp (C)	21.0	20.6	
	HRR (kW)	792.6	0.0	
	Visibility (m) at 2m	20+	20+	

FED gases on egress path = 0.000
 FED thermal on egress path = 0.001

2 min	20 sec (140 sec)	Room 1	Room 2	Outside
	Layer (m)	6.084	1.500	
	Upper Temp (C)	34.5	20.6	
	Lower Temp (C)	21.0	20.6	
	HRR (kW)	919.2	0.0	
	Visibility (m) at 2m	20+	20+	

FED gases on egress path = 0.000
 FED thermal on egress path = 0.001

2 min	30 sec (150 sec)	Room 1	Room 2	Outside
	Layer (m)	5.913	1.500	
	Upper Temp (C)	35.9	20.6	
	Lower Temp (C)	21.0	20.6	
	HRR (kW)	1055.3	0.0	
	Visibility (m) at 2m	20+	20+	

FED gases on egress path = 0.000
 FED thermal on egress path = 0.002

2 min	40 sec (160 sec)	Room 1	Room 2	Outside
	Layer (m)	5.744	1.500	
	Upper Temp (C)	37.3	20.6	
	Lower Temp (C)	21.0	20.6	
	HRR (kW)	1200.6	0.0	
	Visibility (m) at 2m	20+	20+	

FED gases on egress path = 0.000
 FED thermal on egress path = 0.002

2 min	50 sec (170 sec)	Room 1	Room 2	Outside
	Layer (m)	5.577	1.500	
	Upper Temp (C)	38.9	20.6	
	Lower Temp (C)	21.1	20.6	
	HRR (kW)	1355.4	0.0	
	Visibility (m) at 2m	20+	20+	

FED gases on egress path = 0.000
 FED thermal on egress path = 0.002

3 min	00 sec (180 sec)	Room 1	Room 2	Outside
	Layer (m)	5.411	1.500	
	Upper Temp (C)	40.5	20.5	

Lower Temp (C)	21.1	20.5
HRR (kW)	1519.6	0.0
Visibility (m) at 2m	20+	20+

FED gases on egress path = 0.000
 FED thermal on egress path = 0.002

3 min	10 sec (190 sec)	Room 1	Room 2	Outside
	Layer (m)	5.247	1.500	
	Upper Temp (C)	42.2	20.5	
	Lower Temp (C)	21.1	20.5	
	HRR (kW)	1693.1	0.0	
	Visibility (m) at 2m	20+	20+	

FED gases on egress path = 0.000
 FED thermal on egress path = 0.002

3 min	20 sec (200 sec)	Room 1	Room 2	Outside
	Layer (m)	5.084	1.500	
	Upper Temp (C)	44.0	20.5	
	Lower Temp (C)	21.2	20.5	
	HRR (kW)	1876.0	0.0	
	Visibility (m) at 2m	20+	20+	

FED gases on egress path = 0.000
 FED thermal on egress path = 0.002

3 min	30 sec (210 sec)	Room 1	Room 2	Outside
	Layer (m)	4.923	1.500	
	Upper Temp (C)	45.8	20.5	
	Lower Temp (C)	21.2	20.5	
	HRR (kW)	2068.3	0.0	
	Visibility (m) at 2m	20+	20+	

FED gases on egress path = 0.000
 FED thermal on egress path = 0.002

3 min	40 sec (220 sec)	Room 1	Room 2	Outside
	Layer (m)	4.764	1.500	
	Upper Temp (C)	47.7	20.5	
	Lower Temp (C)	21.3	20.5	
	HRR (kW)	2270.0	0.0	
	Visibility (m) at 2m	20+	20+	

FED gases on egress path = 0.000
 FED thermal on egress path = 0.002

3 min	50 sec (230 sec)	Room 1	Room 2	Outside
	Layer (m)	4.605	1.500	
	Upper Temp (C)	49.7	20.4	
	Lower Temp (C)	21.3	20.4	
	HRR (kW)	2481.0	0.0	
	Visibility (m) at 2m	20+	20+	

FED gases on egress path = 0.000
 FED thermal on egress path = 0.002

4 min	00 sec (240 sec)	Room 1	Room 2	Outside
	Layer (m)	4.448	1.500	
	Upper Temp (C)	51.7	20.4	

Lower Temp (C)	21.4	20.4
HRR (kW)	2701.4	0.0
Visibility (m) at 2m	20+	20+

FED gases on egress path = 0.000
 FED thermal on egress path = 0.003

4 min	10 sec (250 sec)	Room 1	Room 2	Outside
-------	---------------------	--------	--------	---------

Layer (m)	4.292	1.500
Upper Temp (C)	53.8	20.4
Lower Temp (C)	21.5	20.4
HRR (kW)	2931.3	0.0
Visibility (m) at 2m	20+	20+

FED gases on egress path = 0.000
 FED thermal on egress path = 0.003

4 min	20 sec (260 sec)	Room 1	Room 2	Outside
-------	---------------------	--------	--------	---------

Layer (m)	4.136	1.500
Upper Temp (C)	55.9	20.4
Lower Temp (C)	21.6	20.4
HRR (kW)	3170.4	0.0
Visibility (m) at 2m	20+	20+

FED gases on egress path = 0.000
 FED thermal on egress path = 0.003

4 min	30 sec (270 sec)	Room 1	Room 2	Outside
-------	---------------------	--------	--------	---------

Layer (m)	3.982	1.500
Upper Temp (C)	58.1	20.4
Lower Temp (C)	21.7	20.4
HRR (kW)	3419.0	0.0
Visibility (m) at 2m	20+	20+

FED gases on egress path = 0.000
 FED thermal on egress path = 0.003

4 min	40 sec (280 sec)	Room 1	Room 2	Outside
-------	---------------------	--------	--------	---------

Layer (m)	3.825	1.500
Upper Temp (C)	60.3	20.3
Lower Temp (C)	21.8	20.3
HRR (kW)	3677.0	0.0
Visibility (m) at 2m	20+	20+

FED gases on egress path = 0.000
 FED thermal on egress path = 0.003

4 min	50 sec (290 sec)	Room 1	Room 2	Outside
-------	---------------------	--------	--------	---------

Layer (m)	3.666	1.500
Upper Temp (C)	62.6	20.3
Lower Temp (C)	22.0	20.3
HRR (kW)	3944.3	0.0
Visibility (m) at 2m	20+	20+

FED gases on egress path = 0.000
 FED thermal on egress path = 0.003

5 min	00 sec (300 sec)	Room 1	Room 2	Outside
-------	---------------------	--------	--------	---------

Layer (m)	3.504	1.500
Upper Temp (C)	64.9	20.3

Lower Temp (C)	22.1	20.3
HRR (kW)	4221.0	0.0
Visibility (m) at 2m	20+	20+

FED gases on egress path = 0.000
 FED thermal on egress path = 0.003

5 min 10 sec
 (310 sec) Room 1 Room 2 Outside

Layer (m)	3.339	1.500
Upper Temp (C)	67.3	20.3
Lower Temp (C)	22.3	20.3
HRR (kW)	4507.1	0.0
Visibility (m) at 2m	20+	20+

FED gases on egress path = 0.000
 FED thermal on egress path = 0.003

5 min 20 sec
 (320 sec) Room 1 Room 2 Outside

Layer (m)	3.171	1.500
Upper Temp (C)	69.8	20.3
Lower Temp (C)	22.4	20.3
HRR (kW)	4802.6	0.0
Visibility (m) at 2m	20+	20+

FED gases on egress path = 0.000
 FED thermal on egress path = 0.003

5 min 30 sec
 (330 sec) Room 1 Room 2 Outside

Layer (m)	3.001	1.500
Upper Temp (C)	72.2	20.2
Lower Temp (C)	22.5	20.2
HRR (kW)	5107.4	0.0
Visibility (m) at 2m	20+	20+

FED gases on egress path = 0.000
 FED thermal on egress path = 0.004

5 min 40 sec
 (340 sec) Room 1 Room 2 Outside

Layer (m)	2.829	1.500
Upper Temp (C)	74.8	20.2
Lower Temp (C)	22.7	20.2
HRR (kW)	5421.6	0.0
Visibility (m) at 2m	20+	20+

FED gases on egress path = 0.000
 FED thermal on egress path = 0.004

5 min 50 sec
 (350 sec) Room 1 Room 2 Outside

Layer (m)	2.657	1.500
Upper Temp (C)	77.4	20.2
Lower Temp (C)	22.8	20.2
HRR (kW)	5745.3	0.0
Visibility (m) at 2m	20+	20+

FED gases on egress path = 0.000
 FED thermal on egress path = 0.004

6 min 00 sec
 (360 sec) Room 1 Room 2 Outside

Layer (m)	2.487	1.500
Upper Temp (C)	80.5	20.2

Lower Temp (C)	23.0	20.2
HRR (kW)	6078.2	0.0
Visibility (m) at 2m	20+	20+

FED gases on egress path = 0.000
 FED thermal on egress path = 0.004

6 min 10 sec
 (370 sec) Room 1 Room 2 Outside

Layer (m)	2.320	1.500
Upper Temp (C)	83.5	20.2
Lower Temp (C)	23.2	20.2
HRR (kW)	6420.6	0.0
Visibility (m) at 2m	20+	20+

FED gases on egress path = 0.000
 FED thermal on egress path = 0.004

6 min 20 sec
 (380 sec) Room 1 Room 2 Outside

Layer (m)	2.157	1.500
Upper Temp (C)	86.5	20.2
Lower Temp (C)	23.5	20.2
HRR (kW)	6772.4	0.0
Visibility (m) at 2m	20+	20+

FED gases on egress path = 0.000
 FED thermal on egress path = 0.004

6 min 30 sec
 (390 sec) Room 1 Room 2 Outside

Layer (m)	2.087	1.500
Upper Temp (C)	91.0	20.1
Lower Temp (C)	23.7	20.1
HRR (kW)	7103.5	0.0
Visibility (m) at 2m	20+	20+

FED gases on egress path = 0.000
 FED thermal on egress path = 0.004

6 min 40 sec
 (400 sec) Room 1 Room 2 Outside

Layer (m)	2.029	1.500
Upper Temp (C)	95.5	20.1
Lower Temp (C)	24.1	20.1
HRR (kW)	7504.0	0.0
Visibility (m) at 2m	20+	20+

FED gases on egress path = 0.000
 FED thermal on egress path = 0.005

6 min 50 sec
 (410 sec) Room 1 Room 2 Outside

Layer (m)	1.973	1.500
Upper Temp (C)	100.0	20.1
Lower Temp (C)	24.5	20.1
HRR (kW)	7883.9	0.0
Visibility (m) at 2m	0.57	20+

FED gases on egress path = 0.001
 FED thermal on egress path = 0.015

7 min 00 sec
 (420 sec) Room 1 Room 2 Outside

Layer (m)	1.922	1.500
Upper Temp (C)	104.3	20.1

Lower Temp (C)	25.0	20.1
HRR (kW)	8273.2	0.0
Visibility (m) at 2m	0.54	20+

FED gases on egress path = 0.003
 FED thermal on egress path = 0.037

7 min 10 sec
 (430 sec) Room 1 Room 2 Outside

Layer (m)	1.872	1.500
Upper Temp (C)	108.6	20.1
Lower Temp (C)	25.6	20.1
HRR (kW)	8671.8	0.0
Visibility (m) at 2m	0.52	20+

FED gases on egress path = 0.006
 FED thermal on egress path = 0.064

7 min 20 sec
 (440 sec) Room 1 Room 2 Outside

Layer (m)	1.823	1.500
Upper Temp (C)	112.9	20.1
Lower Temp (C)	26.3	20.1
HRR (kW)	9079.8	0.0
Visibility (m) at 2m	0.50	20+

FED gases on egress path = 0.008
 FED thermal on egress path = 0.093

7 min 30 sec
 (450 sec) Room 1 Room 2 Outside

Layer (m)	1.777	1.500
Upper Temp (C)	117.3	20.0
Lower Temp (C)	27.1	20.0
HRR (kW)	9497.3	0.0
Visibility (m) at 2m	0.47	20+

FED gases on egress path = 0.011
 FED thermal on egress path = 0.127

7 min 40 sec
 (460 sec) Room 1 Room 2 Outside

Layer (m)	1.731	1.500
Upper Temp (C)	121.6	20.0
Lower Temp (C)	28.1	20.0
HRR (kW)	9924.0	0.0
Visibility (m) at 2m	0.45	20+

FED gases on egress path = 0.014
 FED thermal on egress path = 0.166

7 min 50 sec
 (470 sec) Room 1 Room 2 Outside

Layer (m)	1.685	1.500
Upper Temp (C)	126.0	20.0
Lower Temp (C)	29.1	20.0
HRR (kW)	10360.2	0.0
Visibility (m) at 2m	0.44	20+

FED gases on egress path = 0.017
 FED thermal on egress path = 0.209

8 min 00 sec
 (480 sec) Room 1 Room 2 Outside

Layer (m)	1.639	1.500
Upper Temp (C)	130.4	20.0

Lower Temp (C)	30.2	20.0
HRR (kW)	10805.8	0.0
Visibility (m) at 2m	0.42	20+

FED gases on egress path = 0.020
 FED thermal on egress path = 0.258

8 min 10 sec
 (490 sec) Room 1 Room 2 Outside

Layer (m)	1.593	1.500
Upper Temp (C)	134.9	20.0
Lower Temp (C)	31.2	20.0
HRR (kW)	11260.7	0.0
Visibility (m) at 2m	0.40	20+

FED gases on egress path = 0.024
 FED thermal on egress path = 0.313

8 min 20 sec
 (500 sec) Room 1 Room 2 Outside

Layer (m)	1.548	1.500
Upper Temp (C)	139.4	20.0
Lower Temp (C)	32.3	20.0
HRR (kW)	11725.0	0.0
Visibility (m) at 2m	0.39	20+

FED gases on egress path = 0.028
 FED thermal on egress path = 0.375

8 min 30 sec
 (510 sec) Room 1 Room 2 Outside

Layer (m)	1.503	1.500
Upper Temp (C)	144.0	20.0
Lower Temp (C)	33.2	20.0
HRR (kW)	12198.7	0.0
Visibility (m) at 2m	0.37	20+

FED gases on egress path = 0.032
 FED thermal on egress path = 0.444

8 min 40 sec
 (520 sec) Room 1 Room 2 Outside

Layer (m)	1.463	1.485
Upper Temp (C)	148.7	47.5
Lower Temp (C)	34.1	22.5
HRR (kW)	12681.8	0.0
Visibility (m) at 2m	0.36	0.35

FED gases on egress path = 0.036
 FED thermal on egress path = 0.520

8 min 50 sec
 (530 sec) Room 1 Room 2 Outside

Layer (m)	1.457	1.455
Upper Temp (C)	153.4	45.3
Lower Temp (C)	36.7	24.7
HRR (kW)	13174.2	0.0
Visibility (m) at 2m	0.35	0.30

FED gases on egress path = 0.041
 FED thermal on egress path = 0.606

9 min 00 sec
 (540 sec) Room 1 Room 2 Outside

Layer (m)	1.461	1.429
Upper Temp (C)	158.0	42.2

Lower Temp (C)	41.3	27.3
HRR (kW)	13676.0	0.0
Visibility (m) at 2m	0.33	0.28

FED gases on egress path = 0.046
 FED thermal on egress path = 0.701

9 min	10 sec (550 sec)	Room 1	Room 2	Outside
	Layer (m)	1.461	1.403	
	Upper Temp (C)	162.5	42.0	
	Lower Temp (C)	47.9	30.7	
	HRR (kW)	14187.3	0.0	
	Visibility (m) at 2m	0.32	0.27	

FED gases on egress path = 0.051
 FED thermal on egress path = 0.805

9 min	20 sec (560 sec)	Room 1	Room 2	Outside
	Layer (m)	1.455	1.372	
	Upper Temp (C)	167.1	44.2	
	Lower Temp (C)	54.6	34.9	
	HRR (kW)	14707.8	0.0	
	Visibility (m) at 2m	0.31	0.26	

FED gases on egress path = 0.057
 FED thermal on egress path = 0.920

9 min	30 sec (570 sec)	Room 1	Room 2	Outside
	Layer (m)	1.446	1.333	
	Upper Temp (C)	172.0	47.9	
	Lower Temp (C)	61.0	39.5	
	HRR (kW)	15237.8	0.0	
	Visibility (m) at 2m	0.30	0.25	

FED gases on egress path = 0.063
 FED thermal on egress path = 1.000

9 min	40 sec (580 sec)	Room 1	Room 2	Outside
	Layer (m)	1.435	1.284	
	Upper Temp (C)	177.0	52.2	
	Lower Temp (C)	67.2	44.3	
	HRR (kW)	15777.2	0.0	
	Visibility (m) at 2m	0.29	0.25	

FED gases on egress path = 0.070
 FED thermal on egress path = 1.000

9 min	50 sec (590 sec)	Room 1	Room 2	Outside
	Layer (m)	1.424	1.224	
	Upper Temp (C)	182.1	56.6	
	Lower Temp (C)	73.0	49.1	
	HRR (kW)	16325.9	0.0	
	Visibility (m) at 2m	0.29	0.24	

FED gases on egress path = 0.076
 FED thermal on egress path = 1.000

10 min	00 sec (600 sec)	Room 1	Room 2	Outside
	Layer (m)	1.414	1.154	
	Upper Temp (C)	187.3	60.9	

Lower Temp (C)	78.9	53.6
HRR (kW)	16884.0	0.0
Visibility (m) at 2m	0.28	0.24

FED gases on egress path = 0.084
 FED thermal on egress path = 1.000

10 min	10 sec (610 sec)	Room 1	Room 2	Outside
	Layer (m)	1.404	1.075	
	Upper Temp (C)	192.5	65.0	
	Lower Temp (C)	84.9	57.6	
	HRR (kW)	17451.5	0.0	
	Visibility (m) at 2m	0.27	0.23	

FED gases on egress path = 0.092
 FED thermal on egress path = 1.000

10 min	20 sec (620 sec)	Room 1	Room 2	Outside
	Layer (m)	1.393	0.986	
	Upper Temp (C)	197.7	68.9	
	Lower Temp (C)	90.5	61.9	
	HRR (kW)	18028.4	0.0	
	Visibility (m) at 2m	0.26	0.23	

FED gases on egress path = 0.100
 FED thermal on egress path = 1.000

10 min	30 sec (630 sec)	Room 1	Room 2	Outside
	Layer (m)	1.383	0.882	
	Upper Temp (C)	203.1	72.8	
	Lower Temp (C)	95.9	66.0	
	HRR (kW)	18614.6	0.0	
	Visibility (m) at 2m	0.26	0.22	

FED gases on egress path = 0.109
 FED thermal on egress path = 1.000

10 min	40 sec (640 sec)	Room 1	Room 2	Outside
	Layer (m)	1.372	0.772	
	Upper Temp (C)	208.5	76.5	
	Lower Temp (C)	101.0	70.6	
	HRR (kW)	19210.2	0.0	
	Visibility (m) at 2m	0.25	0.22	

FED gases on egress path = 0.118
 FED thermal on egress path = 1.000

10 min	50 sec (650 sec)	Room 1	Room 2	Outside
	Layer (m)	1.356	0.664	
	Upper Temp (C)	214.0	82.1	
	Lower Temp (C)	105.3	75.9	
	HRR (kW)	19815.3	0.0	
	Visibility (m) at 2m	0.25	0.22	

FED gases on egress path = 0.128
 FED thermal on egress path = 1.000

11 min	00 sec (660 sec)	Room 1	Room 2	Outside
	Layer (m)	1.333	0.586	
	Upper Temp (C)	218.8	87.2	

Lower Temp (C)	109.9	81.4
HRR (kW)	20000.0	0.0
Visibility (m) at 2m	0.24	0.21

FED gases on egress path = 0.139
 FED thermal on egress path = 1.000

11 min 10 sec
 (670 sec) Room 1 Room 2 Outside

Layer (m)	1.329	0.519
Upper Temp (C)	222.9	92.1
Lower Temp (C)	114.6	85.7
HRR (kW)	20000.0	0.0
Visibility (m) at 2m	0.23	0.21

FED gases on egress path = 0.150
 FED thermal on egress path = 1.000

11 min 20 sec
 (680 sec) Room 1 Room 2 Outside

Layer (m)	1.329	0.474
Upper Temp (C)	226.3	95.5
Lower Temp (C)	118.8	89.8
HRR (kW)	20000.0	0.0
Visibility (m) at 2m	0.23	0.21

FED gases on egress path = 0.162
 FED thermal on egress path = 1.000

11 min 30 sec
 (690 sec) Room 1 Room 2 Outside

Layer (m)	1.332	0.450
Upper Temp (C)	229.1	98.4
Lower Temp (C)	122.5	93.1
HRR (kW)	20000.0	0.0
Visibility (m) at 2m	0.22	0.20

FED gases on egress path = 0.174
 FED thermal on egress path = 1.000

11 min 40 sec
 (700 sec) Room 1 Room 2 Outside

Layer (m)	1.333	0.455
Upper Temp (C)	231.5	100.2
Lower Temp (C)	125.6	96.4
HRR (kW)	20000.0	0.0
Visibility (m) at 2m	0.22	0.20

FED gases on egress path = 0.188
 FED thermal on egress path = 1.000

11 min 50 sec
 (710 sec) Room 1 Room 2 Outside

Layer (m)	1.336	0.448
Upper Temp (C)	233.7	101.3
Lower Temp (C)	127.8	98.5
HRR (kW)	20000.0	0.0
Visibility (m) at 2m	0.21	0.19

FED gases on egress path = 0.202
 FED thermal on egress path = 1.000

12 min 00 sec
 (720 sec) Room 1 Room 2 Outside

Layer (m)	1.341	0.448
Upper Temp (C)	235.6	102.3

Lower Temp (C)	129.6	99.9
HRR (kW)	20000.0	0.0
Visibility (m) at 2m	0.21	0.19

FED gases on egress path = 0.216
 FED thermal on egress path = 1.000

12 min	10 sec (730 sec)	Room 1	Room 2	Outside
	Layer (m)	1.294	0.422	
	Upper Temp (C)	237.3	105.1	
	Lower Temp (C)	127.5	98.5	
	HRR (kW)	20000.0	0.0	
	Visibility (m) at 2m	0.21	0.18	

FED gases on egress path = 0.232
 FED thermal on egress path = 1.000

12 min	20 sec (740 sec)	Room 1	Room 2	Outside
	Layer (m)	1.248	0.375	
	Upper Temp (C)	238.4	109.5	
	Lower Temp (C)	126.3	95.9	
	HRR (kW)	20000.0	0.0	
	Visibility (m) at 2m	0.20	0.18	

FED gases on egress path = 0.247
 FED thermal on egress path = 1.000

12 min	30 sec (750 sec)	Room 1	Room 2	Outside
	Layer (m)	1.215	0.369	
	Upper Temp (C)	239.1	113.0	
	Lower Temp (C)	126.9	97.6	
	HRR (kW)	20000.0	0.0	
	Visibility (m) at 2m	0.20	0.18	

FED gases on egress path = 0.263
 FED thermal on egress path = 1.000

12 min	40 sec (760 sec)	Room 1	Room 2	Outside
	Layer (m)	1.199	0.308	
	Upper Temp (C)	240.2	116.6	
	Lower Temp (C)	127.1	94.5	
	HRR (kW)	20000.0	0.0	
	Visibility (m) at 2m	0.20	0.17	

FED gases on egress path = 0.279
 FED thermal on egress path = 1.000

12 min	50 sec (770 sec)	Room 1	Room 2	Outside
	Layer (m)	1.173	0.274	
	Upper Temp (C)	241.0	119.6	
	Lower Temp (C)	127.3	93.6	
	HRR (kW)	20000.0	0.0	
	Visibility (m) at 2m	0.19	0.17	

FED gases on egress path = 0.295
 FED thermal on egress path = 1.000

13 min	00 sec (780 sec)	Room 1	Room 2	Outside
	Layer (m)	1.152	0.239	
	Upper Temp (C)	241.8	122.1	

Lower Temp (C)	127.4	92.2
HRR (kW)	20000.0	0.0
Visibility (m) at 2m	0.19	0.17

FED gases on egress path = 0.311
 FED thermal on egress path = 1.000

13 min	10 sec (790 sec)	Room 1	Room 2	Outside
	Layer (m)	1.130	0.222	
	Upper Temp (C)	242.5	124.3	
	Lower Temp (C)	127.1	91.6	
	HRR (kW)	20000.0	0.0	
	Visibility (m) at 2m	0.19	0.16	

FED gases on egress path = 0.328
 FED thermal on egress path = 1.000

13 min	20 sec (800 sec)	Room 1	Room 2	Outside
	Layer (m)	1.111	0.218	
	Upper Temp (C)	243.2	126.1	
	Lower Temp (C)	126.4	90.5	
	HRR (kW)	20000.0	0.0	
	Visibility (m) at 2m	0.19	0.16	

FED gases on egress path = 0.345
 FED thermal on egress path = 1.000

13 min	30 sec (810 sec)	Room 1	Room 2	Outside
	Layer (m)	1.104	0.164	
	Upper Temp (C)	244.1	127.4	
	Lower Temp (C)	124.9	82.2	
	HRR (kW)	20000.0	0.0	
	Visibility (m) at 2m	0.18	0.16	

FED gases on egress path = 0.362
 FED thermal on egress path = 1.000

13 min	40 sec (820 sec)	Room 1	Room 2	Outside
	Layer (m)	1.094	0.122	
	Upper Temp (C)	244.9	127.7	
	Lower Temp (C)	123.4	75.4	
	HRR (kW)	20000.0	0.0	
	Visibility (m) at 2m	0.18	0.15	

FED gases on egress path = 0.379
 FED thermal on egress path = 1.000

13 min	50 sec (830 sec)	Room 1	Room 2	Outside
	Layer (m)	1.087	0.102	
	Upper Temp (C)	245.6	127.9	
	Lower Temp (C)	121.4	72.3	
	HRR (kW)	20000.0	0.0	
	Visibility (m) at 2m	0.18	0.15	

FED gases on egress path = 0.397
 FED thermal on egress path = 1.000

14 min	00 sec (840 sec)	Room 1	Room 2	Outside
	Layer (m)	1.075	0.102	
	Upper Temp (C)	246.2	128.0	

Lower Temp (C)	118.9	73.8
HRR (kW)	20000.0	0.0
Visibility (m) at 2m	0.18	0.15

FED gases on egress path = 0.415
 FED thermal on egress path = 1.000

14 min 10 sec
 (850 sec) Room 1 Room 2 Outside

Layer (m)	1.059	0.123
Upper Temp (C)	246.6	128.2
Lower Temp (C)	116.1	76.9
HRR (kW)	20000.0	0.0
Visibility (m) at 2m	0.18	0.15

FED gases on egress path = 0.433
 FED thermal on egress path = 1.000

14 min 20 sec
 (860 sec) Room 1 Room 2 Outside

Layer (m)	1.035	0.183
Upper Temp (C)	246.9	128.4
Lower Temp (C)	113.0	82.7
HRR (kW)	20000.0	0.0
Visibility (m) at 2m	0.18	0.15

FED gases on egress path = 0.451
 FED thermal on egress path = 1.000

14 min 30 sec
 (870 sec) Room 1 Room 2 Outside

Layer (m)	1.022	0.225
Upper Temp (C)	247.4	129.3
Lower Temp (C)	110.0	82.0
HRR (kW)	20000.0	0.0
Visibility (m) at 2m	0.17	0.14

FED gases on egress path = 0.470
 FED thermal on egress path = 1.000

14 min 40 sec
 (880 sec) Room 1 Room 2 Outside

Layer (m)	1.008	0.309
Upper Temp (C)	247.6	131.1
Lower Temp (C)	107.2	84.6
HRR (kW)	20000.0	0.0
Visibility (m) at 2m	0.17	0.14

FED gases on egress path = 0.489
 FED thermal on egress path = 1.000

14 min 50 sec
 (890 sec) Room 1 Room 2 Outside

Layer (m)	0.987	0.387
Upper Temp (C)	248.0	130.6
Lower Temp (C)	104.8	87.5
HRR (kW)	20000.0	0.0
Visibility (m) at 2m	0.17	0.14

FED gases on egress path = 0.508
 FED thermal on egress path = 1.000

15 min 00 sec
 (900 sec) Room 1 Room 2 Outside

Layer (m)	0.989	0.419
Upper Temp (C)	248.6	132.5

Lower Temp (C)	103.4	86.6
HRR (kW)	20000.0	0.0
Visibility (m) at 2m	0.17	0.14

FED gases on egress path = 0.528
 FED thermal on egress path = 1.000

15 min	10 sec (910 sec)	Room 1	Room 2	Outside
	Layer (m)	0.995	0.433	
	Upper Temp (C)	249.3	133.1	
	Lower Temp (C)	102.2	85.3	
	HRR (kW)	20000.0	0.0	
	Visibility (m) at 2m	0.17	0.14	

FED gases on egress path = 0.548
 FED thermal on egress path = 1.000

15 min	20 sec (920 sec)	Room 1	Room 2	Outside
	Layer (m)	0.996	0.452	
	Upper Temp (C)	249.8	133.4	
	Lower Temp (C)	101.5	84.7	
	HRR (kW)	20000.0	0.0	
	Visibility (m) at 2m	0.17	0.14	

FED gases on egress path = 0.569
 FED thermal on egress path = 1.000

15 min	30 sec (930 sec)	Room 1	Room 2	Outside
	Layer (m)	0.998	0.468	
	Upper Temp (C)	250.4	133.7	
	Lower Temp (C)	100.9	84.4	
	HRR (kW)	20000.0	0.0	
	Visibility (m) at 2m	0.17	0.13	

FED gases on egress path = 0.589
 FED thermal on egress path = 1.000

15 min	40 sec (940 sec)	Room 1	Room 2	Outside
	Layer (m)	1.001	0.483	
	Upper Temp (C)	251.0	133.9	
	Lower Temp (C)	100.1	84.2	
	HRR (kW)	20000.0	0.0	
	Visibility (m) at 2m	0.16	0.13	

FED gases on egress path = 0.610
 FED thermal on egress path = 1.000

15 min	50 sec (950 sec)	Room 1	Room 2	Outside
	Layer (m)	1.005	0.496	
	Upper Temp (C)	251.4	134.2	
	Lower Temp (C)	100.0	83.3	
	HRR (kW)	20000.0	0.0	
	Visibility (m) at 2m	0.16	0.13	

FED gases on egress path = 0.631
 FED thermal on egress path = 1.000

16 min	00 sec (960 sec)	Room 1	Room 2	Outside
	Layer (m)	1.009	0.503	
	Upper Temp (C)	251.9	134.2	

Lower Temp (C)	99.8	82.6
HRR (kW)	20000.0	0.0
Visibility (m) at 2m	0.16	0.13

FED gases on egress path = 0.653
 FED thermal on egress path = 1.000

16 min 10 sec
 (970 sec) Room 1 Room 2 Outside

Layer (m)	1.013	0.510
Upper Temp (C)	252.4	134.2
Lower Temp (C)	99.3	82.1
HRR (kW)	20000.0	0.0
Visibility (m) at 2m	0.16	0.13

FED gases on egress path = 0.675
 FED thermal on egress path = 1.000

16 min 20 sec
 (980 sec) Room 1 Room 2 Outside

Layer (m)	1.015	0.518
Upper Temp (C)	252.9	134.3
Lower Temp (C)	98.7	81.8
HRR (kW)	20000.0	0.0
Visibility (m) at 2m	0.16	0.13

FED gases on egress path = 0.697
 FED thermal on egress path = 1.000

16 min 30 sec
 (990 sec) Room 1 Room 2 Outside

Layer (m)	1.016	0.527
Upper Temp (C)	253.4	134.3
Lower Temp (C)	98.1	81.5
HRR (kW)	20000.0	0.0
Visibility (m) at 2m	0.16	0.13

FED gases on egress path = 0.719
 FED thermal on egress path = 1.000

16 min 40 sec
 (1000 sec) Room 1 Room 2 Outside

Layer (m)	1.018	0.536
Upper Temp (C)	253.9	134.5
Lower Temp (C)	97.6	81.3
HRR (kW)	20000.0	0.0
Visibility (m) at 2m	0.16	0.13

FED gases on egress path = 0.741
 FED thermal on egress path = 1.000

16 min 50 sec
 (1010 sec) Room 1 Room 2 Outside

Layer (m)	1.019	0.544
Upper Temp (C)	254.4	134.6
Lower Temp (C)	97.2	81.1
HRR (kW)	20000.0	0.0
Visibility (m) at 2m	0.16	0.13

FED gases on egress path = 0.764
 FED thermal on egress path = 1.000

17 min 00 sec
 (1020 sec) Room 1 Room 2 Outside

Layer (m)	1.021	0.551
Upper Temp (C)	254.9	134.9

Lower Temp (C)	96.8	80.9
HRR (kW)	20000.0	0.0
Visibility (m) at 2m	0.16	0.13

FED gases on egress path = 0.787
 FED thermal on egress path = 1.000

17 min 10 sec
 (1030 sec) Room 1 Room 2 Outside

Layer (m)	1.022	0.559
Upper Temp (C)	255.3	135.1
Lower Temp (C)	96.5	80.8
HRR (kW)	20000.0	0.0
Visibility (m) at 2m	0.16	0.12

FED gases on egress path = 0.810
 FED thermal on egress path = 1.000

17 min 20 sec
 (1040 sec) Room 1 Room 2 Outside

Layer (m)	1.023	0.566
Upper Temp (C)	255.8	135.4
Lower Temp (C)	96.2	80.7
HRR (kW)	20000.0	0.0
Visibility (m) at 2m	0.16	0.12

FED gases on egress path = 0.833
 FED thermal on egress path = 1.000

17 min 30 sec
 (1050 sec) Room 1 Room 2 Outside

Layer (m)	1.025	0.573
Upper Temp (C)	256.3	135.6
Lower Temp (C)	95.9	80.6
HRR (kW)	20000.0	0.0
Visibility (m) at 2m	0.16	0.12

FED gases on egress path = 0.856
 FED thermal on egress path = 1.000

17 min 40 sec
 (1060 sec) Room 1 Room 2 Outside

Layer (m)	1.026	0.579
Upper Temp (C)	256.8	135.8
Lower Temp (C)	95.7	80.6
HRR (kW)	20000.0	0.0
Visibility (m) at 2m	0.16	0.12

FED gases on egress path = 0.879
 FED thermal on egress path = 1.000

17 min 50 sec
 (1070 sec) Room 1 Room 2 Outside

Layer (m)	1.027	0.585
Upper Temp (C)	257.3	136.1
Lower Temp (C)	95.5	80.5
HRR (kW)	20000.0	0.0
Visibility (m) at 2m	0.16	0.12

FED gases on egress path = 0.903
 FED thermal on egress path = 1.000

18 min 00 sec
 (1080 sec) Room 1 Room 2 Outside

Layer (m)	1.029	0.590
Upper Temp (C)	257.8	136.3

Lower Temp (C)	95.4	80.5
HRR (kW)	20000.0	0.0
Visibility (m) at 2m	0.16	0.12

FED gases on egress path = 0.927
 FED thermal on egress path = 1.000

18 min	10 sec (1090 sec)	Room 1	Room 2	Outside
	Layer (m)	1.030	0.595	
	Upper Temp (C)	258.2	136.5	
	Lower Temp (C)	95.3	80.5	
	HRR (kW)	20000.0	0.0	
	Visibility (m) at 2m	0.16	0.12	

FED gases on egress path = 0.950
 FED thermal on egress path = 1.000

18 min	20 sec (1100 sec)	Room 1	Room 2	Outside
	Layer (m)	1.031	0.599	
	Upper Temp (C)	258.7	136.8	
	Lower Temp (C)	95.3	80.5	
	HRR (kW)	20000.0	0.0	
	Visibility (m) at 2m	0.16	0.12	

FED gases on egress path = 0.974
 FED thermal on egress path = 1.000

18 min	30 sec (1110 sec)	Room 1	Room 2	Outside
	Layer (m)	1.033	0.603	
	Upper Temp (C)	259.1	137.0	
	Lower Temp (C)	95.3	80.5	
	HRR (kW)	20000.0	0.0	
	Visibility (m) at 2m	0.16	0.12	

FED gases on egress path = 0.998
 FED thermal on egress path = 1.000

18 min	40 sec (1120 sec)	Room 1	Room 2	Outside
	Layer (m)	1.034	0.606	
	Upper Temp (C)	259.6	137.2	
	Lower Temp (C)	95.3	80.6	
	HRR (kW)	20000.0	0.0	
	Visibility (m) at 2m	0.16	0.12	

FED gases on egress path = 1.000
 FED thermal on egress path = 1.000

18 min	50 sec (1130 sec)	Room 1	Room 2	Outside
	Layer (m)	1.035	0.610	
	Upper Temp (C)	260.0	137.4	
	Lower Temp (C)	95.3	80.7	
	HRR (kW)	20000.0	0.0	
	Visibility (m) at 2m	0.15	0.12	

FED gases on egress path = 1.000
 FED thermal on egress path = 1.000

19 min	00 sec (1140 sec)	Room 1	Room 2	Outside
	Layer (m)	1.037	0.613	
	Upper Temp (C)	260.5	137.7	

Lower Temp (C)	95.4	80.8
HRR (kW)	20000.0	0.0
Visibility (m) at 2m	0.15	0.12

FED gases on egress path = 1.000
 FED thermal on egress path = 1.000

19 min 10 sec
 (1150 sec) Room 1 Room 2 Outside

Layer (m)	1.038	0.615
Upper Temp (C)	260.9	137.9
Lower Temp (C)	95.4	80.9
HRR (kW)	20000.0	0.0
Visibility (m) at 2m	0.15	0.12

FED gases on egress path = 1.000
 FED thermal on egress path = 1.000

19 min 20 sec
 (1160 sec) Room 1 Room 2 Outside

Layer (m)	1.039	0.618
Upper Temp (C)	261.3	138.1
Lower Temp (C)	95.5	81.0
HRR (kW)	20000.0	0.0
Visibility (m) at 2m	0.15	0.12

FED gases on egress path = 1.000
 FED thermal on egress path = 1.000

19 min 30 sec
 (1170 sec) Room 1 Room 2 Outside

Layer (m)	1.040	0.620
Upper Temp (C)	261.7	138.4
Lower Temp (C)	95.6	81.1
HRR (kW)	20000.0	0.0
Visibility (m) at 2m	0.15	0.12

FED gases on egress path = 1.000
 FED thermal on egress path = 1.000

19 min 40 sec
 (1180 sec) Room 1 Room 2 Outside

Layer (m)	1.041	0.623
Upper Temp (C)	262.1	138.6
Lower Temp (C)	95.8	81.2
HRR (kW)	20000.0	0.0
Visibility (m) at 2m	0.15	0.12

FED gases on egress path = 1.000
 FED thermal on egress path = 1.000

19 min 50 sec
 (1190 sec) Room 1 Room 2 Outside

Layer (m)	1.042	0.625
Upper Temp (C)	262.5	138.8
Lower Temp (C)	95.9	81.4
HRR (kW)	20000.0	0.0
Visibility (m) at 2m	0.15	0.12

FED gases on egress path = 1.000
 FED thermal on egress path = 1.000

20 min 00 sec
 (1200 sec) Room 1 Room 2 Outside

Layer (m)	1.043	0.626
Upper Temp (C)	262.9	139.0

Lower Temp (C)	96.0	81.5
HRR (kW)	20000.0	0.0
Visibility (m) at 2m	0.15	0.12

FED gases on egress path = 1.000
FED thermal on egress path = 1.000

=====
Event Log
=====

Simulation Finished.

FED(thermal) Exceeded 0.3 at 490.0 Seconds.

FED(CO) Exceeded 0.3 at 775.0 Seconds.

410 sec. Visibility at 2m above floor reduced to 10 m in room 1

0 sec. Item 1 Fire ignited.

Iteration 1

=====
Initial Time-Step = 5.00 seconds.

Computer Run-Time = 13.2 seconds.
=====

Visibility in Circus Ring (Room 1) at 2 m above floor reduces to less than 10 m at 410 seconds.

FED (CO) in Circus Ring (Room 1) exceeded 0.3 at 775 seconds

FED (THERMAL) in Circus Ring (Room 1) exceeded 0.3 at 490 seconds.

Released Under the
Official Information Act 1982

25 APPENDIX 5 – B-Risk RESULTS – CF2**18.1. Branzfire Results – CF2****Design Fire 2: Fire underneath seating**

Tuesday, August 20, 2013, 04:18 PM

B-RISK Fire Simulator and Design Fire Tool (Ver 2013.12)

Input Filename : input1.xml

Base File : C:\Users\Owner\Documents\B-

RISK\riskdata\basemodel_Zirka_Circus\basemodel_Zirka_Circus.xml

User Mode : C/VM2

Zirka Circus

Description of Rooms

Room 1 : Circus Room

Room Length (m) =	31.00
Room Width (m) =	31.00
Maximum Room Height (m) =	10.00
Minimum Room Height (m) =	4.00
Floor Elevation (m) =	0.000
Absolute X Position (m) =	0.000
Absolute Y Position (m) =	0.000
Room 1 has a sloping ceiling.	
Shape Factor (Af/H^2) =	9.6

Wall Surface is steel (mild)	
Wall Density (kg/m3) =	7850.0
Wall Conductivity (W/m.K) =	45.800
Wall Specific Heat (J/kg.K) =	460
Wall Emissivity =	0.90
Wall Thickness (mm) =	3.0

Ceiling Surface is steel (mild)	
Ceiling Density (kg/m3) =	7850.0
Ceiling Conductivity (W/m.K) =	45.800
Ceiling Specific Heat (J/kg.K) =	460
Ceiling Emissivity =	0.90
Ceiling Thickness (mm) =	3.0

Floor Surface is concrete	
Floor Density (kg/m3) =	2300.0
Floor Conductivity (W/m.K) =	1.200
Floor Specific Heat (J/kg.K) =	880
Floor Emissivity =	0.50
Floor Thickness (mm) =	100.0

Room 2 : Bleachers

Room Length (m) =	31.00
Room Width (m) =	8.00
Maximum Room Height (m) =	1.50
Minimum Room Height (m) =	1.50
Floor Elevation (m) =	0.000
Absolute X Position (m) =	0.000
Absolute Y Position (m) =	31.000
Room 2 has a flat ceiling.	
Shape Factor (Af/H^2) =	110.2

Wall Surface is steel (mild)	
Wall Density (kg/m3) =	7850.0
Wall Conductivity (W/m.K) =	45.800
Wall Specific Heat (J/kg.K) =	460

Wall Emissivity =	0.90
Wall Thickness (mm) =	3.0
Ceiling Surface is steel (mild)	
Ceiling Density (kg/m3) =	7850.0
Ceiling Conductivity (W/m.K) =	45.800
Ceiling Specific Heat (J/kg.K) =	460
Ceiling Emissivity =	0.90
Ceiling Thickness (mm) =	3.0
Floor Surface is concrete	
Floor Density (kg/m3) =	2300.0
Floor Conductivity (W/m.K) =	1.200
Floor Specific Heat (J/kg.K) =	880
Floor Emissivity =	0.50
Floor Thickness = (mm)	100.0

=====

Wall Vents

=====

Vent 1 : Vent above front entran

From room 1 to 3

Front face of room 1

Offset (m) = 14.870

Vent Width (m) = 1.160

Vent Height (m) = 1.160

Vent Sill Height (m) = 1.800

Vent Soffit Height (m) = 2.960

Opening Time (sec) = 110

Closing Time (sec) = 0

Flow Coefficient (sec) = 0.680

Vent 2 : Vent above right door

From room 1 to 3

Right face of room 1

Offset (m) = 12.900

Vent Width (m) = 1.160

Vent Height (m) = 1.160

Vent Sill Height (m) = 1.800

Vent Soffit Height (m) = 2.960

Opening Time (sec) = 110

Closing Time (sec) = 0

Flow Coefficient (sec) = 0.680

Vent 3 : Vent above left door

From room 1 to 3

Left face of room 1

Offset (m) = 12.900

Vent Width (m) = 1.160

Vent Height (m) = 1.160

Vent Sill Height (m) = 1.800

Vent Soffit Height (m) = 2.960

Opening Time (sec) = 110

Closing Time (sec) = 0

Flow Coefficient (sec) = 0.680

Vent 4 : Door opening from entra

From room 1 to 3

Front face of room 1

Offset (m) = 13.800

Vent Width (m) = 1.700

Vent Height (m) = 1.800

Vent Sill Height (m) = 0.000

Vent Soffit Height (m) = 1.800

Opening Time (sec) = 110

Closing Time (sec) = 0

Flow Coefficient (sec) = 0.680

Vent 5 : Door opening Right face

From room 1 to 3

Right face of room 1

Offset (m) = 11.800

Vent Width (m) =	1.700
Vent Height (m) =	1.800
Vent Sill Height (m) =	0.000
Vent Soffit Height (m) =	1.800
Opening Time (sec) =	110
Closing Time (sec) =	0
Flow Coefficient (sec) =	0.680

Vent 6 : Door Opening left face

From room 1 to 3	
Left face of room 1	
Offset (m) =	11.800
Vent Width (m) =	1.700
Vent Height (m) =	1.800
Vent Sill Height (m) =	0.000
Vent Soffit Height (m) =	1.800
Opening Time (sec) =	110
Closing Time (sec) =	0
Flow Coefficient (sec) =	0.680

Vent 7 : Bleachers height

From room 1 to 2	
Rear face of room 1	
Offset (m) =	0.000
Vent Width (m) =	31.000
Vent Height (m) =	1.500
Vent Sill Height (m) =	0.000
Vent Soffit Height (m) =	1.500
Opening Time (sec) =	0
Closing Time (sec) =	0
Flow Coefficient (sec) =	0.680
Vent Type is 3D adhered spill plume	
Balcony Width (m) =	0.000
Downstand Depth (m) =	8.500

Vent 8 : ceiling vent

From room 1 to 3	
Rear face of room 1	
Offset (m) =	15.500
Vent Width (m) =	2.000
Vent Height (m) =	2.000
Vent Sill Height (m) =	6.000
Vent Soffit Height (m) =	8.000
Opening Time (sec) =	0
Closing Time (sec) =	0
Flow Coefficient (sec) =	0.680

=====
Ceiling/Floor Vents
==========
Ambient Conditions
=====

Interior Temp (C) =	21.0
Exterior Temp (C) =	18.0
Relative Humidity (%) =	50

=====
Tenability Parameters
=====

Monitoring Height for Visibility and FED (m) =	2.00
Asphyxiant gas model =	FED(CO) C/VM2
Visibility calculations assume:	reflective signs
Egress path segments for FED calculations	
1. Start Time (sec)	0
1. End Time (sec)	600
1. Room	1
2. Start Time (sec)	600
2. End Time (sec)	900
2. Room	1
3. Start Time (sec)	900
3. End Time (sec)	1200

3. Room 1

=====

Sprinkler / Detector Parameters

=====

Ceiling Jet model used is NIST JET.
 Sprinkler System Reliability 1.000
 Sprinkler Probability of Suppression 1.000
 Sprinkler Cooling Coefficient 1.000

=====

Smoke Detector Parameters

=====

Smoke Detection System Reliability 1.000

=====

Mechanical Ventilation (to/from outside)

=====

Mechanical Ventilation not installed.
 Mech ventilation system reliability 1.000

=====

Description of the Fire

=====

CO Yield pre-flashover(g/g) = 0.040
 CO Yield post-flashover(g/g) = 0.400
 Soot Yield pre-flashover(g/g) = 0.070
 Soot Yield post-flashover(g/g) = 0.140
 Flame Emission Coefficient (1/m) = 1.00
 Fuel - Carbon Moles 1.00
 Fuel - Hydrogen Moles 2.00
 Fuel - Oxygen Moles 0.50
 Fuel - Nitrogen Moles 0.00

Burning objects are manually positioned in room.

Burning Object No 1
 Fire

Located in Room 2
 Energy Yield (kJ/g) = 20.0
 CO2 Yield (kg/kg fuel) = 1.500
 HCN Yield (kg/kg fuel) = 0.000
 H2O Yield (kg/kg fuel) = 0.818
 Heat Release Rate Per Unit Area (kW/m2) = 250.0
 Radiant Loss Fraction = 0.35
 Fire Elevation (m) = 0.300
 Fire Object Length (m) = 0.300
 Fire Object Width (m) = 0.300
 Fire Object Height (m) = 0.000
 Location, X-coordinate (m) = 15.500
 Location, Y-coordinate (m) = 4.000
 Fire Location (for entrainment) = centre
 Plume behaviour is undisturbed
 Alpha T₃ growth coefficient = 0.0469
 Peak HRR (kW) = 20000

=====

Postflashover Inputs

=====

Postflashover model is OFF.

=====

Results from Fire Simulation

=====

0 min 00 sec
 (0 sec) Room 1 Room 2 Outside

Layer (m)	9.908	1.500
Upper Temp (C)	21.0	21.0
Lower Temp (C)	21.0	21.0
HRR (kW)	0.0	0.0
Visibility (m) at 2m	20+	20+

FED gases on egress path = 0.000
 FED thermal on egress path = 0.000

0 min 10 sec
 (10 sec) Room 1 Room 2 Outside

Layer (m)	9.907	1.497
Upper Temp (C)	21.0	23.7
Lower Temp (C)	21.0	21.0
HRR (kW)	0.0	4.7
Visibility (m) at 2m	20+	4.74

FED gases on egress path = 0.000
 FED thermal on egress path = 0.000

0 min 20 sec
 (20 sec) Room 1 Room 2 Outside

Layer (m)	9.571	1.490
Upper Temp (C)	20.9	28.4
Lower Temp (C)	20.9	21.0
HRR (kW)	0.0	18.8
Visibility (m) at 2m	20+	1.94

FED gases on egress path = 0.000
 FED thermal on egress path = 0.000

0 min 30 sec
 (30 sec) Room 1 Room 2 Outside

Layer (m)	9.219	1.480
Upper Temp (C)	21.0	33.9
Lower Temp (C)	20.9	21.0
HRR (kW)	0.0	42.2
Visibility (m) at 2m	20+	1.21

FED gases on egress path = 0.000
 FED thermal on egress path = 0.000

0 min 40 sec
 (40 sec) Room 1 Room 2 Outside

Layer (m)	8.839	1.466
Upper Temp (C)	21.0	39.3
Lower Temp (C)	20.9	21.0
HRR (kW)	0.0	75.0
Visibility (m) at 2m	20+	0.88

FED gases on egress path = 0.000
 FED thermal on egress path = 0.000

0 min 50 sec
 (50 sec) Room 1 Room 2 Outside

Layer (m)	8.482	1.452
Upper Temp (C)	21.1	44.0
Lower Temp (C)	20.9	21.0
HRR (kW)	0.0	117.3
Visibility (m) at 2m	20+	0.69

FED gases on egress path = 0.000
 FED thermal on egress path = 0.001

1 min 00 sec
 (60 sec) Room 1 Room 2 Outside

Layer (m)	8.147	1.436
Upper Temp (C)	21.3	49.1
Lower Temp (C)	20.9	21.1
HRR (kW)	0.0	168.8
Visibility (m) at 2m	20+	0.57

FED gases on egress path = 0.000
 FED thermal on egress path = 0.001

1 min 10 sec
 (70 sec) Room 1 Room 2 Outside

Layer (m)	7.816	1.420
Upper Temp (C)	21.5	54.2
Lower Temp (C)	20.9	21.2
HRR (kW)	0.0	229.8
Visibility (m) at 2m	20+	0.49

FED gases on egress path = 0.000
 FED thermal on egress path = 0.001

1 min 20 sec
 (80 sec) Room 1 Room 2 Outside

Layer (m)	7.504	1.405
Upper Temp (C)	21.7	59.8
Lower Temp (C)	20.9	21.4
HRR (kW)	0.0	300.2
Visibility (m) at 2m	20+	0.43

FED gases on egress path = 0.000
 FED thermal on egress path = 0.001

1 min 30 sec
 (90 sec) Room 1 Room 2 Outside

Layer (m)	7.202	1.392
Upper Temp (C)	22.0	65.8
Lower Temp (C)	20.9	21.6
HRR (kW)	0.0	379.9
Visibility (m) at 2m	20+	0.39

FED gases on egress path = 0.000
 FED thermal on egress path = 0.001

1 min 40 sec
 (100 sec) Room 1 Room 2 Outside

Layer (m)	6.913	1.380
Upper Temp (C)	22.4	72.3
Lower Temp (C)	20.9	21.8
HRR (kW)	0.0	469.0
Visibility (m) at 2m	20+	0.36

FED gases on egress path = 0.000
 FED thermal on egress path = 0.001

1 min 50 sec
 (110 sec) Room 1 Room 2 Outside

Layer (m)	6.638	1.370
Upper Temp (C)	22.7	80.5
Lower Temp (C)	20.9	22.1
HRR (kW)	0.0	567.5
Visibility (m) at 2m	20+	0.33

FED gases on egress path = 0.000
 FED thermal on egress path = 0.001

2 min 00 sec
 (120 sec) Room 1 Room 2 Outside

Layer (m)	6.391	1.363
Upper Temp (C)	23.0	89.0
Lower Temp (C)	20.9	22.5
HRR (kW)	0.0	675.4
Visibility (m) at 2m	20+	0.31

FED gases on egress path = 0.000
 FED thermal on egress path = 0.001

2 min 10 sec
 (130 sec) Room 1 Room 2 Outside

Layer (m)	6.161	1.355
Upper Temp (C)	23.4	96.6
Lower Temp (C)	20.8	22.9
HRR (kW)	0.0	792.6
Visibility (m) at 2m	20+	0.29

FED gases on egress path = 0.000
 FED thermal on egress path = 0.001

2 min 20 sec
 (140 sec) Room 1 Room 2 Outside

Layer (m)	5.943	1.347
Upper Temp (C)	23.9	103.2
Lower Temp (C)	20.8	23.3
HRR (kW)	0.0	919.2
Visibility (m) at 2m	20+	0.28

FED gases on egress path = 0.000
 FED thermal on egress path = 0.001

2 min 30 sec
 (150 sec) Room 1 Room 2 Outside

Layer (m)	5.731	1.338
Upper Temp (C)	24.4	110.6
Lower Temp (C)	20.8	23.8
HRR (kW)	0.0	1055.3
Visibility (m) at 2m	20+	0.27

FED gases on egress path = 0.000
 FED thermal on egress path = 0.002

2 min 40 sec
 (160 sec) Room 1 Room 2 Outside

Layer (m)	5.525	1.329
Upper Temp (C)	25.0	118.3
Lower Temp (C)	20.9	24.2
HRR (kW)	0.0	1200.6
Visibility (m) at 2m	20+	0.26

FED gases on egress path = 0.000
 FED thermal on egress path = 0.002

2 min 50 sec
 (170 sec) Room 1 Room 2 Outside

Layer (m)	5.324	1.320
Upper Temp (C)	25.6	126.1
Lower Temp (C)	20.9	24.7
HRR (kW)	0.0	1355.4
Visibility (m) at 2m	20+	0.26

FED gases on egress path = 0.000
 FED thermal on egress path = 0.002

3 min 00 sec
 (180 sec) Room 1 Room 2 Outside

Layer (m)	5.127	1.312
Upper Temp (C)	26.3	133.9
Lower Temp (C)	20.9	25.1
HRR (kW)	0.0	1519.6
Visibility (m) at 2m	20+	0.25

FED gases on egress path = 0.000
FED thermal on egress path = 0.002

3 min 10 sec
(190 sec) Room 1 Room 2 Outside

Layer (m)	4.936	1.303
Upper Temp (C)	27.0	141.7
Lower Temp (C)	20.9	25.6
HRR (kW)	0.0	1693.1
Visibility (m) at 2m	20+	0.25

FED gases on egress path = 0.000
FED thermal on egress path = 0.002

3 min 20 sec
(200 sec) Room 1 Room 2 Outside

Layer (m)	4.749	1.293
Upper Temp (C)	27.8	149.4
Lower Temp (C)	20.9	26.1
HRR (kW)	0.0	1876.0
Visibility (m) at 2m	20+	0.25

FED gases on egress path = 0.000
FED thermal on egress path = 0.002

3 min 30 sec
(210 sec) Room 1 Room 2 Outside

Layer (m)	4.567	1.284
Upper Temp (C)	28.6	157.2
Lower Temp (C)	21.0	26.5
HRR (kW)	0.0	2068.3
Visibility (m) at 2m	20+	0.24

FED gases on egress path = 0.000
FED thermal on egress path = 0.002

3 min 40 sec
(220 sec) Room 1 Room 2 Outside

Layer (m)	4.389	1.275
Upper Temp (C)	29.5	164.9
Lower Temp (C)	21.0	27.0
HRR (kW)	0.0	2270.0
Visibility (m) at 2m	20+	0.24

FED gases on egress path = 0.000
FED thermal on egress path = 0.002

3 min 50 sec
(230 sec) Room 1 Room 2 Outside

Layer (m)	4.216	1.266
Upper Temp (C)	30.5	172.5
Lower Temp (C)	21.1	27.5
HRR (kW)	0.0	2481.0
Visibility (m) at 2m	20+	0.24

FED gases on egress path = 0.000
FED thermal on egress path = 0.002

4 min 00 sec
(240 sec) Room 1 Room 2 Outside

Layer (m)	4.047	1.256
Upper Temp (C)	31.5	180.2
Lower Temp (C)	21.1	28.0
HRR (kW)	0.0	2701.4
Visibility (m) at 2m	20+	0.24

FED gases on egress path = 0.000
 FED thermal on egress path = 0.002

4 min 10 sec
 (250 sec) Room 1 Room 2 Outside

Layer (m)	3.880	1.247
Upper Temp (C)	32.6	187.4
Lower Temp (C)	21.2	28.5
HRR (kW)	0.0	2931.3
Visibility (m) at 2m	20+	0.23

FED gases on egress path = 0.000
 FED thermal on egress path = 0.003

4 min 20 sec
 (260 sec) Room 1 Room 2 Outside

Layer (m)	3.712	1.238
Upper Temp (C)	33.7	193.1
Lower Temp (C)	21.2	28.9
HRR (kW)	0.0	3170.4
Visibility (m) at 2m	20+	0.23

FED gases on egress path = 0.000
 FED thermal on egress path = 0.003

4 min 30 sec
 (270 sec) Room 1 Room 2 Outside

Layer (m)	3.541	1.228
Upper Temp (C)	34.8	200.0
Lower Temp (C)	21.3	29.3
HRR (kW)	0.0	3419.0
Visibility (m) at 2m	20+	0.23

FED gases on egress path = 0.000
 FED thermal on egress path = 0.003

4 min 40 sec
 (280 sec) Room 1 Room 2 Outside

Layer (m)	3.367	1.218
Upper Temp (C)	36.0	207.3
Lower Temp (C)	21.4	29.7
HRR (kW)	0.0	3677.0
Visibility (m) at 2m	20+	0.23

FED gases on egress path = 0.000
 FED thermal on egress path = 0.003

4 min 50 sec
 (290 sec) Room 1 Room 2 Outside

Layer (m)	3.194	1.208
Upper Temp (C)	37.2	214.6
Lower Temp (C)	21.5	30.2
HRR (kW)	0.0	3944.3
Visibility (m) at 2m	20+	0.22

FED gases on egress path = 0.000
 FED thermal on egress path = 0.003

5 min 00 sec
 (300 sec) Room 1 Room 2 Outside

Layer (m)	3.024	1.199
Upper Temp (C)	38.5	221.7
Lower Temp (C)	21.6	30.8
HRR (kW)	0.0	4221.0
Visibility (m) at 2m	20+	0.22

FED gases on egress path = 0.000
 FED thermal on egress path = 0.003

5 min 10 sec
 (310 sec) Room 1 Room 2 Outside

Layer (m)	2.859	1.189
Upper Temp (C)	39.9	228.9
Lower Temp (C)	21.7	31.3
HRR (kW)	0.0	4507.1
Visibility (m) at 2m	20+	0.22

FED gases on egress path = 0.000
 FED thermal on egress path = 0.003

5 min 20 sec
 (320 sec) Room 1 Room 2 Outside

Layer (m)	2.699	1.180
Upper Temp (C)	41.4	236.0
Lower Temp (C)	21.8	31.9
HRR (kW)	0.0	4802.6
Visibility (m) at 2m	20+	0.22

FED gases on egress path = 0.000
 FED thermal on egress path = 0.003

5 min 30 sec
 (330 sec) Room 1 Room 2 Outside

Layer (m)	2.546	1.171
Upper Temp (C)	42.9	243.0
Lower Temp (C)	21.9	32.5
HRR (kW)	0.0	5107.4
Visibility (m) at 2m	20+	0.22

FED gases on egress path = 0.000
 FED thermal on egress path = 0.003

5 min 40 sec
 (340 sec) Room 1 Room 2 Outside

Layer (m)	2.399	1.161
Upper Temp (C)	44.6	250.0
Lower Temp (C)	22.0	33.1
HRR (kW)	0.0	5421.6
Visibility (m) at 2m	20+	0.22

FED gases on egress path = 0.000
 FED thermal on egress path = 0.004

5 min 50 sec
 (350 sec) Room 1 Room 2 Outside

Layer (m)	2.259	1.152
Upper Temp (C)	46.2	256.9
Lower Temp (C)	22.2	33.8
HRR (kW)	0.0	5745.3
Visibility (m) at 2m	20+	0.22

FED gases on egress path = 0.000
 FED thermal on egress path = 0.004

6 min 00 sec
 (360 sec) Room 1 Room 2 Outside

	Layer (m)	2.124	1.142	
	Upper Temp (C)	48.0	263.9	
	Lower Temp (C)	22.3	34.4	
	HRR (kW)	0.0	6078.2	
	Visibility (m) at 2m	20+	0.21	
	FED gases on egress path = 0.000			
	FED thermal on egress path = 0.004			
6 min	10 sec (370 sec)	Room 1	Room 2	Outside
	Layer (m)	1.989	1.133	
	Upper Temp (C)	49.8	270.8	
	Lower Temp (C)	22.5	35.2	
	HRR (kW)	0.0	6420.6	
	Visibility (m) at 2m	0.72	0.21	
	FED gases on egress path = 0.001			
	FED thermal on egress path = 0.005			
6 min	20 sec (380 sec)	Room 1	Room 2	Outside
	Layer (m)	1.855	1.124	
	Upper Temp (C)	51.6	277.0	
	Lower Temp (C)	22.7	35.9	
	HRR (kW)	0.0	6772.4	
	Visibility (m) at 2m	0.69	0.21	
	FED gases on egress path = 0.002			
	FED thermal on egress path = 0.007			
6 min	30 sec (390 sec)	Room 1	Room 2	Outside
	Layer (m)	1.720	1.115	
	Upper Temp (C)	53.6	280.2	
	Lower Temp (C)	23.0	36.7	
	HRR (kW)	0.0	7133.5	
	Visibility (m) at 2m	0.66	0.21	
	FED gases on egress path = 0.004			
	FED thermal on egress path = 0.009			
6 min	40 sec (400 sec)	Room 1	Room 2	Outside
	Layer (m)	1.584	1.105	
	Upper Temp (C)	55.7	286.8	
	Lower Temp (C)	23.2	37.6	
	HRR (kW)	0.0	7504.0	
	Visibility (m) at 2m	0.63	0.21	
	FED gases on egress path = 0.005			
	FED thermal on egress path = 0.012			
6 min	50 sec (410 sec)	Room 1	Room 2	Outside
	Layer (m)	1.450	1.096	
	Upper Temp (C)	57.7	293.5	
	Lower Temp (C)	23.6	38.8	
	HRR (kW)	0.0	7883.9	
	Visibility (m) at 2m	0.60	0.21	
	FED gases on egress path = 0.007			
	FED thermal on egress path = 0.015			
7 min	00 sec (420 sec)	Room 1	Room 2	Outside

Layer (m)	1.345	1.084
Upper Temp (C)	59.8	300.3
Lower Temp (C)	24.6	40.3
HRR (kW)	0.0	8273.2
Visibility (m) at 2m	0.58	0.21

FED gases on egress path = 0.009
 FED thermal on egress path = 0.019

7 min 10 sec
 (430 sec) Room 1 Room 2 Outside

Layer (m)	1.247	1.071
Upper Temp (C)	61.9	307.1
Lower Temp (C)	26.0	43.2
HRR (kW)	0.0	8671.8
Visibility (m) at 2m	0.55	0.20

FED gases on egress path = 0.011
 FED thermal on egress path = 0.022

7 min 20 sec
 (440 sec) Room 1 Room 2 Outside

Layer (m)	1.155	1.059
Upper Temp (C)	64.1	314.0
Lower Temp (C)	28.0	49.4
HRR (kW)	0.0	9079.8
Visibility (m) at 2m	0.53	0.20

FED gases on egress path = 0.013
 FED thermal on egress path = 0.027

7 min 30 sec
 (450 sec) Room 1 Room 2 Outside

Layer (m)	1.066	1.049
Upper Temp (C)	66.3	321.4
Lower Temp (C)	30.7	59.7
HRR (kW)	0.0	9497.3
Visibility (m) at 2m	0.51	0.20

FED gases on egress path = 0.015
 FED thermal on egress path = 0.032

7 min 40 sec
 (460 sec) Room 1 Room 2 Outside

Layer (m)	1.044	1.045
Upper Temp (C)	69.2	329.4
Lower Temp (C)	33.9	73.5
HRR (kW)	0.0	9924.0
Visibility (m) at 2m	0.49	0.20

FED gases on egress path = 0.018
 FED thermal on egress path = 0.037

7 min 50 sec
 (470 sec) Room 1 Room 2 Outside

Layer (m)	1.046	1.046
Upper Temp (C)	72.5	337.3
Lower Temp (C)	37.6	90.2
HRR (kW)	0.0	10360.2
Visibility (m) at 2m	0.46	0.20

FED gases on egress path = 0.020
 FED thermal on egress path = 0.044

8 min 00 sec
 (480 sec) Room 1 Room 2 Outside

	Layer (m)	1.044	1.044	
	Upper Temp (C)	75.9	347.7	
	Lower Temp (C)	41.7	105.7	
	HRR (kW)	0.0	10805.8	
	Visibility (m) at 2m	0.44	0.20	
	FED gases on egress path = 0.023			
	FED thermal on egress path = 0.051			
8 min	10 sec (490 sec)	Room 1	Room 2	Outside
	Layer (m)	1.039	1.039	
	Upper Temp (C)	79.6	356.6	
	Lower Temp (C)	45.7	119.8	
	HRR (kW)	0.0	11260.7	
	Visibility (m) at 2m	0.42	0.20	
	FED gases on egress path = 0.026			
	FED thermal on egress path = 0.060			
8 min	20 sec (500 sec)	Room 1	Room 2	Outside
	Layer (m)	1.031	1.033	
	Upper Temp (C)	83.7	365.5	
	Lower Temp (C)	49.7	133.2	
	HRR (kW)	0.0	11725.0	
	Visibility (m) at 2m	0.40	0.20	
	FED gases on egress path = 0.030			
	FED thermal on egress path = 0.071			
8 min	30 sec (510 sec)	Room 1	Room 2	Outside
	Layer (m)	1.007	1.023	
	Upper Temp (C)	87.7	374.3	
	Lower Temp (C)	53.5	145.5	
	HRR (kW)	0.0	12198.7	
	Visibility (m) at 2m	0.39	0.19	
	FED gases on egress path = 0.034			
	FED thermal on egress path = 0.083			
8 min	40 sec (520 sec)	Room 1	Room 2	Outside
	Layer (m)	0.999	1.011	
	Upper Temp (C)	91.9	381.9	
	Lower Temp (C)	57.1	155.9	
	HRR (kW)	0.0	12681.8	
	Visibility (m) at 2m	0.37	0.19	
	FED gases on egress path = 0.038			
	FED thermal on egress path = 0.098			
8 min	50 sec (530 sec)	Room 1	Room 2	Outside
	Layer (m)	0.985	1.000	
	Upper Temp (C)	96.4	385.8	
	Lower Temp (C)	60.5	165.1	
	HRR (kW)	0.0	13174.2	
	Visibility (m) at 2m	0.36	0.19	
	FED gases on egress path = 0.042			
	FED thermal on egress path = 0.115			
9 min	00 sec (540 sec)	Room 1	Room 2	Outside

Layer (m)	0.989	0.990
Upper Temp (C)	100.9	394.1
Lower Temp (C)	63.6	174.8
HRR (kW)	0.0	13676.0
Visibility (m) at 2m	0.34	0.19

FED gases on egress path = 0.047
 FED thermal on egress path = 0.135

9 min 10 sec
 (550 sec) Room 1 Room 2 Outside

Layer (m)	0.977	0.977
Upper Temp (C)	105.1	402.3
Lower Temp (C)	66.8	184.6
HRR (kW)	0.0	14187.3
Visibility (m) at 2m	0.33	0.19

FED gases on egress path = 0.052
 FED thermal on egress path = 0.158

9 min 20 sec
 (560 sec) Room 1 Room 2 Outside

Layer (m)	0.965	0.965
Upper Temp (C)	109.3	410.5
Lower Temp (C)	69.8	194.2
HRR (kW)	0.0	14707.8
Visibility (m) at 2m	0.32	0.18

FED gases on egress path = 0.058
 FED thermal on egress path = 0.185

9 min 30 sec
 (570 sec) Room 1 Room 2 Outside

Layer (m)	0.950	0.953
Upper Temp (C)	113.4	418.6
Lower Temp (C)	72.5	203.6
HRR (kW)	0.0	15237.8
Visibility (m) at 2m	0.30	0.18

FED gases on egress path = 0.064
 FED thermal on egress path = 0.215

9 min 40 sec
 (580 sec) Room 1 Room 2 Outside

Layer (m)	0.938	0.941
Upper Temp (C)	117.6	426.7
Lower Temp (C)	75.0	212.7
HRR (kW)	0.0	15777.2
Visibility (m) at 2m	0.29	0.18

FED gases on egress path = 0.070
 FED thermal on egress path = 0.250

9 min 50 sec
 (590 sec) Room 1 Room 2 Outside

Layer (m)	0.915	0.927
Upper Temp (C)	121.6	434.5
Lower Temp (C)	78.0	221.2
HRR (kW)	0.0	16325.9
Visibility (m) at 2m	0.28	0.18

FED gases on egress path = 0.077
 FED thermal on egress path = 0.288

10 min 00 sec
 (600 sec) Room 1 Room 2 Outside

Layer (m)	0.908	0.912
Upper Temp (C)	125.6	441.7
Lower Temp (C)	81.1	228.1
HRR (kW)	0.0	16884.0
Visibility (m) at 2m	0.27	0.17

FED gases on egress path = 0.085
 FED thermal on egress path = 0.332

10 min 10 sec
 (610 sec) Room 1 Room 2 Outside

Layer (m)	0.894	0.902
Upper Temp (C)	129.5	449.8
Lower Temp (C)	84.0	236.7
HRR (kW)	0.0	17451.5
Visibility (m) at 2m	0.26	0.17

FED gases on egress path = 0.093
 FED thermal on egress path = 0.380

10 min 20 sec
 (620 sec) Room 1 Room 2 Outside

Layer (m)	0.888	0.887
Upper Temp (C)	133.5	457.8
Lower Temp (C)	86.5	245.5
HRR (kW)	0.0	18028.4
Visibility (m) at 2m	0.26	0.17

FED gases on egress path = 0.101
 FED thermal on egress path = 0.433

10 min 30 sec
 (630 sec) Room 1 Room 2 Outside

Layer (m)	0.876	0.875
Upper Temp (C)	137.3	465.5
Lower Temp (C)	88.8	253.9
HRR (kW)	0.0	18614.6
Visibility (m) at 2m	0.25	0.17

FED gases on egress path = 0.111
 FED thermal on egress path = 0.492

10 min 40 sec
 (640 sec) Room 1 Room 2 Outside

Layer (m)	0.863	0.862
Upper Temp (C)	141.2	473.4
Lower Temp (C)	91.1	262.6
HRR (kW)	0.0	19210.2
Visibility (m) at 2m	0.24	0.16

FED gases on egress path = 0.120
 FED thermal on egress path = 0.557

10 min 50 sec
 (650 sec) Room 1 Room 2 Outside

Layer (m)	0.868	0.848
Upper Temp (C)	145.3	479.8
Lower Temp (C)	93.0	267.9
HRR (kW)	0.0	19815.3
Visibility (m) at 2m	0.23	0.16

FED gases on egress path = 0.131
 FED thermal on egress path = 0.629

11 min 00 sec
 (660 sec) Room 1 Room 2 Outside

Layer (m)	0.846	0.841
Upper Temp (C)	149.3	479.9
Lower Temp (C)	95.3	273.1
HRR (kW)	0.0	20000.0
Visibility (m) at 2m	0.22	0.16

FED gases on egress path = 0.142
 FED thermal on egress path = 0.707

11 min 10 sec
 (670 sec) Room 1 Room 2 Outside

Layer (m)	0.849	0.835
Upper Temp (C)	152.9	483.5
Lower Temp (C)	97.4	274.8
HRR (kW)	0.0	20000.0
Visibility (m) at 2m	0.22	0.16

FED gases on egress path = 0.155
 FED thermal on egress path = 0.793

11 min 20 sec
 (680 sec) Room 1 Room 2 Outside

Layer (m)	0.844	0.832
Upper Temp (C)	156.1	485.5
Lower Temp (C)	99.9	278.3
HRR (kW)	0.0	20000.0
Visibility (m) at 2m	0.21	0.15

FED gases on egress path = 0.168
 FED thermal on egress path = 0.885

11 min 30 sec
 (690 sec) Room 1 Room 2 Outside

Layer (m)	0.858	0.831
Upper Temp (C)	158.9	487.1
Lower Temp (C)	100.2	281.3
HRR (kW)	0.0	20000.0
Visibility (m) at 2m	0.21	0.15

FED gases on egress path = 0.181
 FED thermal on egress path = 0.983

11 min 40 sec
 (700 sec) Room 1 Room 2 Outside

Layer (m)	0.830	0.832
Upper Temp (C)	161.3	488.3
Lower Temp (C)	99.8	284.1
HRR (kW)	0.0	20000.0
Visibility (m) at 2m	0.20	0.15

FED gases on egress path = 0.196
 FED thermal on egress path = 1.000

11 min 50 sec
 (710 sec) Room 1 Room 2 Outside

Layer (m)	0.864	0.830
Upper Temp (C)	163.5	489.2
Lower Temp (C)	101.9	285.3
HRR (kW)	0.0	20000.0
Visibility (m) at 2m	0.20	0.15

FED gases on egress path = 0.211
 FED thermal on egress path = 1.000

12 min 00 sec
 (720 sec) Room 1 Room 2 Outside

Layer (m)	0.818	0.826
Upper Temp (C)	166.1	488.8
Lower Temp (C)	96.7	282.7
HRR (kW)	0.0	20000.0
Visibility (m) at 2m	0.19	0.15

FED gases on egress path = 0.227
 FED thermal on egress path = 1.000

12 min 10 sec
 (730 sec) Room 1 Room 2 Outside

Layer (m)	0.825	0.826
Upper Temp (C)	168.9	488.5
Lower Temp (C)	95.2	281.0
HRR (kW)	0.0	20000.0
Visibility (m) at 2m	0.18	0.15

FED gases on egress path = 0.243
 FED thermal on egress path = 1.000

12 min 20 sec
 (740 sec) Room 1 Room 2 Outside

Layer (m)	0.821	0.825
Upper Temp (C)	170.8	489.2
Lower Temp (C)	95.8	281.9
HRR (kW)	0.0	20000.0
Visibility (m) at 2m	0.18	0.16

FED gases on egress path = 0.259
 FED thermal on egress path = 1.000

12 min 30 sec
 (750 sec) Room 1 Room 2 Outside

Layer (m)	0.818	0.823
Upper Temp (C)	172.7	489.9
Lower Temp (C)	95.2	282.1
HRR (kW)	0.0	20000.0
Visibility (m) at 2m	0.17	0.16

FED gases on egress path = 0.275
 FED thermal on egress path = 1.000

12 min 40 sec
 (760 sec) Room 1 Room 2 Outside

Layer (m)	0.821	0.823
Upper Temp (C)	174.3	490.5
Lower Temp (C)	95.0	281.9
HRR (kW)	0.0	20000.0
Visibility (m) at 2m	0.17	0.16

FED gases on egress path = 0.292
 FED thermal on egress path = 1.000

12 min 50 sec
 (770 sec) Room 1 Room 2 Outside

Layer (m)	0.805	0.817
Upper Temp (C)	175.2	491.5
Lower Temp (C)	95.5	281.9
HRR (kW)	0.0	20000.0
Visibility (m) at 2m	0.17	0.16

FED gases on egress path = 0.308
 FED thermal on egress path = 1.000

13 min 00 sec
 (780 sec) Room 1 Room 2 Outside

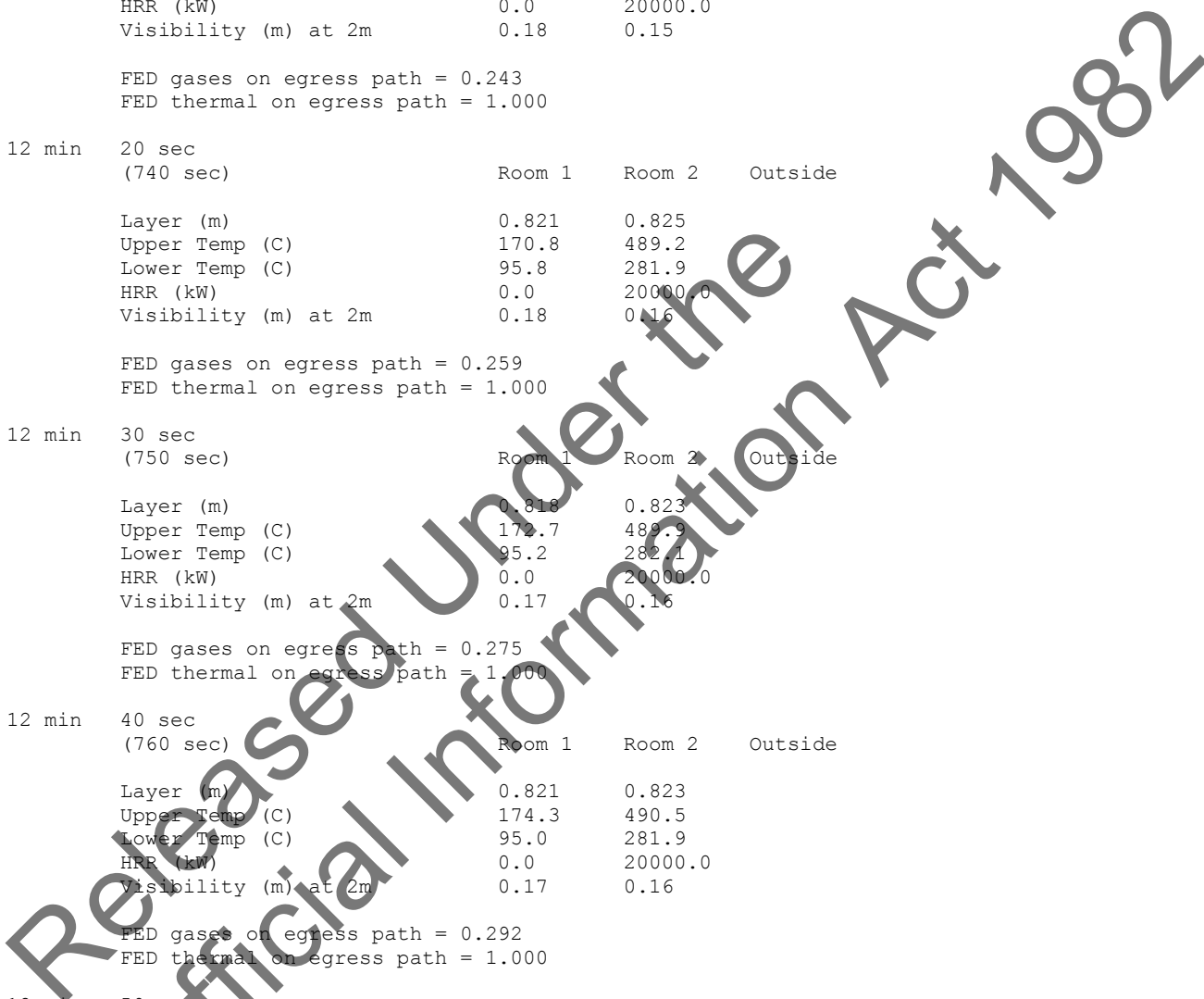

Layer (m)	0.806	0.816
Upper Temp (C)	176.4	491.5
Lower Temp (C)	95.8	278.6
HRR (kW)	0.0	20000.0
Visibility (m) at 2m	0.16	0.17

FED gases on egress path = 0.326
FED thermal on egress path = 1.000

13 min 10 sec
(790 sec) Room 1 Room 2 Outside

Layer (m)	0.812	0.817
Upper Temp (C)	177.5	490.9
Lower Temp (C)	95.6	277.1
HRR (kW)	0.0	20000.0
Visibility (m) at 2m	0.16	0.17

FED gases on egress path = 0.343
FED thermal on egress path = 1.000

13 min 20 sec
(800 sec) Room 1 Room 2 Outside

Layer (m)	0.793	0.812
Upper Temp (C)	178.0	490.4
Lower Temp (C)	94.4	275.4
HRR (kW)	0.0	20000.0
Visibility (m) at 2m	0.16	0.17

FED gases on egress path = 0.361
FED thermal on egress path = 1.000

13 min 30 sec
(810 sec) Room 1 Room 2 Outside

Layer (m)	0.822	0.812
Upper Temp (C)	179.3	489.7
Lower Temp (C)	93.0	268.9
HRR (kW)	0.0	20000.0
Visibility (m) at 2m	0.16	0.17

FED gases on egress path = 0.379
FED thermal on egress path = 1.000

13 min 40 sec
(820 sec) Room 1 Room 2 Outside

Layer (m)	0.778	0.809
Upper Temp (C)	179.2	489.0
Lower Temp (C)	91.7	262.0
HRR (kW)	0.0	20000.0
Visibility (m) at 2m	0.16	0.17

FED gases on egress path = 0.397
FED thermal on egress path = 1.000

13 min 50 sec
(830 sec) Room 1 Room 2 Outside

Layer (m)	0.810	0.809
Upper Temp (C)	180.3	488.2
Lower Temp (C)	89.6	252.4
HRR (kW)	0.0	20000.0
Visibility (m) at 2m	0.15	0.17

FED gases on egress path = 0.416
FED thermal on egress path = 1.000

14 min 00 sec
(840 sec) Room 1 Room 2 Outside

Layer (m)	0.774	0.802
Upper Temp (C)	179.9	487.5
Lower Temp (C)	87.7	244.5
HRR (kW)	0.0	20000.0
Visibility (m) at 2m	0.15	0.17

FED gases on egress path = 0.435
 FED thermal on egress path = 1.000

14 min 10 sec
 (850 sec) Room 1 Room 2 Outside

Layer (m)	0.805	0.802
Upper Temp (C)	181.1	486.8
Lower Temp (C)	85.7	235.0
HRR (kW)	0.0	20000.0
Visibility (m) at 2m	0.15	0.17

FED gases on egress path = 0.454
 FED thermal on egress path = 1.000

14 min 20 sec
 (860 sec) Room 1 Room 2 Outside

Layer (m)	0.771	0.797
Upper Temp (C)	180.7	486.2
Lower Temp (C)	83.9	227.6
HRR (kW)	0.0	20000.0
Visibility (m) at 2m	0.15	0.17

FED gases on egress path = 0.473
 FED thermal on egress path = 1.000

14 min 30 sec
 (870 sec) Room 1 Room 2 Outside

Layer (m)	0.800	0.799
Upper Temp (C)	181.5	485.8
Lower Temp (C)	81.9	219.7
HRR (kW)	0.0	20000.0
Visibility (m) at 2m	0.15	0.17

FED gases on egress path = 0.493
 FED thermal on egress path = 1.000

14 min 40 sec
 (880 sec) Room 1 Room 2 Outside

Layer (m)	0.770	0.799
Upper Temp (C)	181.3	485.6
Lower Temp (C)	80.9	215.0
HRR (kW)	0.0	20000.0
Visibility (m) at 2m	0.15	0.17

FED gases on egress path = 0.513
 FED thermal on egress path = 1.000

14 min 50 sec
 (890 sec) Room 1 Room 2 Outside

Layer (m)	0.764	0.788
Upper Temp (C)	181.2	485.8
Lower Temp (C)	79.4	213.3
HRR (kW)	0.0	20000.0
Visibility (m) at 2m	0.15	0.17

FED gases on egress path = 0.534
 FED thermal on egress path = 1.000

15 min 00 sec
 (900 sec) Room 1 Room 2 Outside

Layer (m)	0.795	0.796
Upper Temp (C)	182.5	486.0
Lower Temp (C)	78.3	207.8
HRR (kW)	0.0	20000.0
Visibility (m) at 2m	0.14	0.17

FED gases on egress path = 0.555
 FED thermal on egress path = 1.000

15 min 10 sec
 (910 sec) Room 1 Room 2 Outside

Layer (m)	0.782	0.789
Upper Temp (C)	182.3	486.7
Lower Temp (C)	77.2	204.5
HRR (kW)	0.0	20000.0
Visibility (m) at 2m	0.14	0.17

FED gases on egress path = 0.575
 FED thermal on egress path = 1.000

15 min 20 sec
 (920 sec) Room 1 Room 2 Outside

Layer (m)	0.782	0.793
Upper Temp (C)	182.9	486.8
Lower Temp (C)	76.6	204.2
HRR (kW)	0.0	20000.0
Visibility (m) at 2m	0.14	0.17

FED gases on egress path = 0.597
 FED thermal on egress path = 1.000

15 min 30 sec
 (930 sec) Room 1 Room 2 Outside

Layer (m)	0.795	0.795
Upper Temp (C)	183.5	487.3
Lower Temp (C)	76.2	203.9
HRR (kW)	0.0	20000.0
Visibility (m) at 2m	0.14	0.17

FED gases on egress path = 0.618
 FED thermal on egress path = 1.000

15 min 40 sec
 (940 sec) Room 1 Room 2 Outside

Layer (m)	0.782	0.794
Upper Temp (C)	183.8	488.0
Lower Temp (C)	75.3	202.8
HRR (kW)	0.0	20000.0
Visibility (m) at 2m	0.14	0.17

FED gases on egress path = 0.640
 FED thermal on egress path = 1.000

15 min 50 sec
 (950 sec) Room 1 Room 2 Outside

Layer (m)	0.767	0.788
Upper Temp (C)	183.6	488.2
Lower Temp (C)	74.7	201.4
HRR (kW)	0.0	20000.0
Visibility (m) at 2m	0.14	0.17

FED gases on egress path = 0.662
 FED thermal on egress path = 1.000

16 min 00 sec
 (960 sec) Room 1 Room 2 Outside

Layer (m)	0.769	0.795
Upper Temp (C)	184.3	488.3
Lower Temp (C)	74.4	198.3
HRR (kW)	0.0	20000.0
Visibility (m) at 2m	0.14	0.17

FED gases on egress path = 0.685
 FED thermal on egress path = 1.000

16 min 10 sec
 (970 sec) Room 1 Room 2 Outside

Layer (m)	0.764	0.785
Upper Temp (C)	184.4	489.0
Lower Temp (C)	73.7	198.0
HRR (kW)	0.0	20000.0
Visibility (m) at 2m	0.14	0.17

FED gases on egress path = 0.707
 FED thermal on egress path = 1.000

16 min 20 sec
 (980 sec) Room 1 Room 2 Outside

Layer (m)	0.764	0.793
Upper Temp (C)	185.1	489.1
Lower Temp (C)	73.4	195.1
HRR (kW)	0.0	20000.0
Visibility (m) at 2m	0.14	0.17

FED gases on egress path = 0.730
 FED thermal on egress path = 1.000

16 min 30 sec
 (990 sec) Room 1 Room 2 Outside

Layer (m)	0.761	0.781
Upper Temp (C)	185.1	488.7
Lower Temp (C)	72.8	195.6
HRR (kW)	0.0	20000.0
Visibility (m) at 2m	0.14	0.17

FED gases on egress path = 0.753
 FED thermal on egress path = 1.000

16 min 40 sec
 (1000 sec) Room 1 Room 2 Outside

Layer (m)	0.786	0.790
Upper Temp (C)	186.5	490.0
Lower Temp (C)	72.4	192.9
HRR (kW)	0.0	20000.0
Visibility (m) at 2m	0.14	0.17

FED gases on egress path = 0.776
 FED thermal on egress path = 1.000

16 min 50 sec
 (1010 sec) Room 1 Room 2 Outside

Layer (m)	0.778	0.785
Upper Temp (C)	186.7	490.8
Lower Temp (C)	72.4	192.4
HRR (kW)	0.0	20000.0
Visibility (m) at 2m	0.14	0.17

FED gases on egress path = 0.799
 FED thermal on egress path = 1.000

17 min 00 sec
 (1020 sec) Room 1 Room 2 Outside

Layer (m)	0.786	0.790
Upper Temp (C)	187.3	490.8
Lower Temp (C)	72.3	192.4
HRR (kW)	0.0	20000.0
Visibility (m) at 2m	0.14	0.17

FED gases on egress path = 0.823
 FED thermal on egress path = 1.000

17 min 10 sec
 (1030 sec) Room 1 Room 2 Outside

Layer (m)	0.764	0.784
Upper Temp (C)	187.1	491.3
Lower Temp (C)	72.4	192.9
HRR (kW)	0.0	20000.0
Visibility (m) at 2m	0.14	0.17

FED gases on egress path = 0.847
 FED thermal on egress path = 1.000

17 min 20 sec
 (1040 sec) Room 1 Room 2 Outside

Layer (m)	0.768	0.791
Upper Temp (C)	187.9	491.5
Lower Temp (C)	72.3	190.7
HRR (kW)	0.0	20000.0
Visibility (m) at 2m	0.14	0.17

FED gases on egress path = 0.870
 FED thermal on egress path = 1.000

17 min 30 sec
 (1050 sec) Room 1 Room 2 Outside

Layer (m)	0.761	0.779
Upper Temp (C)	187.8	491.7
Lower Temp (C)	71.7	190.7
HRR (kW)	0.0	20000.0
Visibility (m) at 2m	0.14	0.17

FED gases on egress path = 0.895
 FED thermal on egress path = 1.000

17 min 40 sec
 (1060 sec) Room 1 Room 2 Outside

Layer (m)	0.787	0.788
Upper Temp (C)	189.1	492.2
Lower Temp (C)	71.3	188.0
HRR (kW)	0.0	20000.0
Visibility (m) at 2m	0.13	0.17

FED gases on egress path = 0.919
 FED thermal on egress path = 1.000

17 min 50 sec
 (1070 sec) Room 1 Room 2 Outside

Layer (m)	0.778	0.783
Upper Temp (C)	189.1	493.0
Lower Temp (C)	71.3	188.0
HRR (kW)	0.0	20000.0
Visibility (m) at 2m	0.13	0.17

FED gases on egress path = 0.943
 FED thermal on egress path = 1.000

18 min 00 sec
 (1080 sec) Room 1 Room 2 Outside

Layer (m)	0.791	0.782
Upper Temp (C)	189.6	492.6
Lower Temp (C)	71.6	189.0
HRR (kW)	0.0	20000.0
Visibility (m) at 2m	0.13	0.17

FED gases on egress path = 0.968
 FED thermal on egress path = 1.000

18 min 10 sec
 (1090 sec) Room 1 Room 2 Outside

Layer (m)	0.761	0.783
Upper Temp (C)	189.3	493.6
Lower Temp (C)	72.3	192.6
HRR (kW)	0.0	20000.0
Visibility (m) at 2m	0.13	0.17

FED gases on egress path = 0.992
 FED thermal on egress path = 1.000

18 min 20 sec
 (1100 sec) Room 1 Room 2 Outside

Layer (m)	0.782	0.783
Upper Temp (C)	190.3	494.3
Lower Temp (C)	73.3	193.5
HRR (kW)	0.0	20000.0
Visibility (m) at 2m	0.13	0.17

FED gases on egress path = 1.000
 FED thermal on egress path = 1.000

18 min 30 sec
 (1110 sec) Room 1 Room 2 Outside

Layer (m)	0.772	0.781
Upper Temp (C)	190.5	495.5
Lower Temp (C)	73.3	194.3
HRR (kW)	0.0	20000.0
Visibility (m) at 2m	0.13	0.17

FED gases on egress path = 1.000
 FED thermal on egress path = 1.000

18 min 40 sec
 (1120 sec) Room 1 Room 2 Outside

Layer (m)	0.755	0.789
Upper Temp (C)	190.8	495.2
Lower Temp (C)	73.1	192.7
HRR (kW)	0.0	20000.0
Visibility (m) at 2m	0.13	0.17

FED gases on egress path = 1.000
 FED thermal on egress path = 1.000

18 min 50 sec
 (1130 sec) Room 1 Room 2 Outside

Layer (m)	0.788	0.784
Upper Temp (C)	191.8	495.2
Lower Temp (C)	73.0	191.5
HRR (kW)	0.0	20000.0
Visibility (m) at 2m	0.13	0.17

FED gases on egress path = 1.000
 FED thermal on egress path = 1.000

19 min 00 sec
 (1140 sec) Room 1 Room 2 Outside

Layer (m)	0.755	0.779
Upper Temp (C)	191.3	495.5
Lower Temp (C)	72.6	190.7
HRR (kW)	0.0	20000.0
Visibility (m) at 2m	0.13	0.17

FED gases on egress path = 1.000
 FED thermal on egress path = 1.000

19 min 10 sec
 (1150 sec) Room 1 Room 2 Outside

Layer (m)	0.788	0.786
Upper Temp (C)	192.6	495.5
Lower Temp (C)	72.6	190.5
HRR (kW)	0.0	20000.0
Visibility (m) at 2m	0.13	0.17

FED gases on egress path = 1.000
 FED thermal on egress path = 1.000

19 min 20 sec
 (1160 sec) Room 1 Room 2 Outside

Layer (m)	0.783	0.780
Upper Temp (C)	192.7	495.8
Lower Temp (C)	73.6	192.9
HRR (kW)	0.0	20000.0
Visibility (m) at 2m	0.13	0.17

FED gases on egress path = 1.000
 FED thermal on egress path = 1.000

19 min 30 sec
 (1170 sec) Room 1 Room 2 Outside

Layer (m)	0.760	0.775
Upper Temp (C)	192.2	495.4
Lower Temp (C)	73.3	195.3
HRR (kW)	0.0	20000.0
Visibility (m) at 2m	0.13	0.17

FED gases on egress path = 1.000
 FED thermal on egress path = 1.000

19 min 40 sec
 (1180 sec) Room 1 Room 2 Outside

Layer (m)	0.788	0.786
Upper Temp (C)	193.6	496.8
Lower Temp (C)	73.5	193.8
HRR (kW)	0.0	20000.0
Visibility (m) at 2m	0.13	0.17

FED gases on egress path = 1.000
 FED thermal on egress path = 1.000

19 min 50 sec
 (1190 sec) Room 1 Room 2 Outside

Layer (m)	0.785	0.776
Upper Temp (C)	193.6	496.6
Lower Temp (C)	73.9	194.8
HRR (kW)	0.0	20000.0
Visibility (m) at 2m	0.13	0.17

FED gases on egress path = 1.000
 FED thermal on egress path = 1.000

20 min 00 sec
 (1200 sec) Room 1 Room 2 Outside

Layer (m)	0.759	0.780
Upper Temp (C)	193.4	497.5
Lower Temp (C)	74.1	196.5
HRR (kW)	0.0	20000.0
Visibility (m) at 2m	0.13	0.17

FED gases on egress path = 1.000
FED thermal on egress path = 1.000

=====
Event Log
=====

Simulation Finished.
FED(thermal) Exceeded 0.3 at 595.0 Seconds.
FED(CO) Exceeded 0.3 at 765.0 Seconds.
10 sec. Visibility at 2m above floor reduced to 10 m in room 2
0 sec. Item 1 Fire ignited.
Iteration 1

=====
Initial Time-Step = 5.00 seconds.
Computer Run-Time = 8.3 seconds.
=====

Visibility in Circus Ring (Room 1) at 2 m above floor reduces to less than 10 m at 360 seconds.

FED (CO) in Circus Ring (Room 1) exceeded 0.3 at 765 seconds

FED (THERMAL) in Circus Ring (Room 1) exceeded 0.3 at 595 seconds.

Released Under the
Official Information Act 1982

26 Appendix 6 - Fire Engineering Brief (FEB)

Released Under the
Official Information Act 1982

UNFIRE

ZIRKA CIRCUS

FEB

Job number: 1942 | 14 June 2013 | Issue 2

Released Under the
Official Information Act 1982

Issue	Date	Author	Status	Extent of Revision
FEB	20 May 2013	DLS PJR	DRAFT for discussion	Fire Engineering Brief
FEB	14 June 2013	DLS	For Approval	Fire Engineering Brief

Prepared by:



Debbie Scott

Principal Fire Engineer

ME Dist (Fire), PMSFPE, FIPENZ, CPEng

Reviewed by:



Peter Reddin

Senior Fire Engineer

ME (Fire), PMSFPE, MIPENZ, CPEng



OnFire Consulting Limited

477 Alexandra Street, PO Box 226, Te Awamutu 3840, New Zealand

Phone: 07 870 6411 Fax: 07 870 6412

Email: info@onfire.co.nz; www.onfire.co.nz

Table of Contents

1	PURPOSE	4
2	INTRODUCTION	4
3	BUILDING IMPORTANCE LEVEL AND RISK GROUPS	4
4	FIRE ENGINEERING BRIEF (FEB)	5
4.1	COMPLIANCE METHODOLOGY	5
4.2	PROPOSED IMPROVEMENTS TO THE MEANS OF ESCAPE FOR THE TENT	5
4.3	RELEVANT DESIGN FIRE SCENARIOS IN ACCORDANCE WITH C/VM2	6
4.4	CHALLENGING FIRE	7
4.5	C/VM2 DESIGN FIRE SCENARIO LIFE SAFETY RULES AND PARAMETERS	7
4.6	C/VM2 DESIGN FIRE CHARACTERISTICS: PRE-FLASHOVER FIRES	9
4.7	B RISK SETUP	9
5	MOVEMENT OF PEOPLE	9
5.1	OCCUPANT LOADS.....	9
5.2	DETECTOR CRITERIA.....	9
5.3	NOTIFICATION TIME	10
5.4	PRE-TRAVEL ACTIVITY TIMES	10
5.5	TRAVEL TIMES.....	10
7	APPENDIX 1 – DRAWINGS AND PHOTOS AND OTHER RELEVANT INFO	12
8	APPENDIX 2 – DIMENSIONS, B-RISK SETUP AND VENTS	13

1 Purpose

The purpose of this Fire Engineering Brief is to obtain agreement from the peer-reviewer and other relevant parties on the design methodology and input parameters for acceptance of the FEB and thereafter implementing the fire engineering design (and any necessary changes to the building design) leading to multi-proof building consent to show compliance with the New Zealand Building Code (NZBC) for Protection from Fire as required by the Building Act 2004 for the building.

2 Introduction

This is an existing circus tent that travels the country throughout the year and is likely to be erected 50 weeks of the year. Given the need for multiple consents throughout the year a Multi-Proof consent through the Ministry of Business, Innovation and Employment (MBIE) is to be applied for. The details in this fire engineering brief relate to the Code Clauses C1-C6. Other Code Clauses are to be dealt with by the applicant with MBIE.

The circus tent is in the process of purchasing new seating and the proposed number of seats is 690 however this is dependent upon the results of this fire engineering design. The seating arrangement may need to be changed on the basis of this review.

The existing circus tent is made of a fabric called Ferrari F702 "Big Top". Testing has been undertaken by AWTA for Baytex who are NZ's leading Tent and Marquee Manufacturer and the flammability index achieved was 5. The Fabric on this circus tent is clearly stamped and hallmarked by the manufacturer, showing that this is indeed the fabric used.

This FEB report, drawings and photos at the rear of this FEB report in Appendix 1 and the dimensions, B-Risk Setup and vent arrangement in Appendix 2 form the fire engineering documentation. A site visit to the tent was also undertaken on the 30th April when it was erected in Hamilton.

3 Building Importance Level and Risk Groups

In accordance with Clause A3 of the Building Code the building Importance Level has been classified as follows:

Importance Level	Description of Building Type	Specific Structure
IL 3	Buildings of a higher level of societal benefit or importance, or with higher levels of risk-significant factors to building occupants. These buildings have increased performance requirements because they may house large numbers of people, vulnerable populations, or occupants with other risk factors, or fulfil a role of increased importance to the local community or to society in general.	Buildings where more than 300 people congregate in 1 area

Although C/VM2 does not specify Risk Groups per-se, they are applicable to some sections of the Verification Method:

Location	Risk Group	Acceptable Solution	Escape Height
Circus Tent	CA	C/AS4	<4.0m

4 Fire Engineering Brief (FEB)

The FEB process for this building includes the following people and organisations as interested and affected parties:

Peer Reviewer	Nick Saunders - MBIE	email:	Nick.saunders@mbie.govt.nz
BCA	Nick Saunders - MBIE	email:	Nick.saunders@mbie.govt.nz
Tent Owner	James Finlayson	email:	james@zirkacircus.com
NZFS	NZFS Engineering Unit	email:	engineers@fire.org.nz
Design Fire Engineer	Debbie Scott	email	Debbie@onfire.co.nz

4.1 Compliance Methodology

The circus tent is not compliant with the relevant Acceptable Solution C/AS4 for the following reasons:

- It does not have traditional 'doorways' and instead has quickly opened tent flaps
- The seating structure is not fire rated
- A compliant smoke detection system to NZS4512 is not able to be installed
- The tent uses stage smoke causing issues with smoke detection

Therefore the relevant design scenarios of the Verification Method must be used to show compliance with the NZBC Protection from Fire clauses C1-C6.

4.2 Proposed improvements to the means of escape for the tent

There is no 'alteration' being proposed to the circus tent and the reason for needing a Consent is due to the tent being moved to a new site every few weeks.

For this tent the following possible improvements from the current situation are proposed in order to improve the means of escape:

- Emergency lighting on battery backup to be provided,
- Additional exit signage to be provided to show people the route to the three main egress tent doors

4.3 Relevant design fire scenarios in accordance with C/VM2

The following design fire scenarios are applicable to the fire modelling for the ASET/RSET calculations for pre- and post-alteration.

DFS	Description	Methods available	Reqd? What method
1:BE Blocked Exit	Escape routes serving >50p, Separation $\geq 8m < 250p$; $\geq 20m > 250p$	>1 escape route required (3 provided)	Yes
2: UT Unknown Threat	Rooms with >50p	a) ASET/RSET, or b) Separation: i. Burnout if no AFD ii. If AFD: A. -/60/60 FRR or Demonstrate effectiveness	N/A in large open circus tent
3:CS Concealed Space	Rooms with >50p, concealed space >0.8m in 2 dimensions	a) Separation, or b) Automatic fire detection (AFD)	N/A – no concealed spaces
4:SF Smouldering Fire	Slow smouldering fire threatens sleeping occupants.	Provide smoke detection throughout	N/A – no sleeping
5:HS Horizontal Spread	Exposure to other property, sleeping occupancy or exitway	a) Calculate radiation, or b) Use tabulated values from C/AS2 to C/AS6 as applicable	Table values to be used and tent to be located far from boundaries
6:VS Vertical Spread	Upper floors with sleeping, or other property, and All buildings >10m. A) Spread over façade materials B) Fire plumes via openings & UPA's	A) a) Large scale tests b) Small scale tests c) Use non-combustible materials	N/A
7:IS Internal Surfaces	Criteria for lining materials, some exceptions	Achieve requirements in Building Code	Tent fabric tested to flammability index
8:FO Firefighting Ops.	a) FSO at 1200 sec (no AFA) b) FSO at 1000 sec with AFA c) FBIM	For unsprinklered firecells <15m to boundary with: i) FLED >20TJ, or ii) Floor area >5000m ²	FLED < 20TJ
	Access within 20m of:	a) Building entry, and b) Inlets to sprinklers, hydrants	Access available
	Water supply	a) Fire Appliance <75m, or	Yes 75m metre
9:CF Challenging Fire	I. Design fires in various locations.	ASET/RSET analysis for all building occupants from design fires in various locations (except a ,b, c). Also assess internal & external escape routes. Assess FED & visibility.	Design fires required <ul style="list-style-type: none"> • Underneath seating • Centre of circus ring

		Assume active & passive systems will perform as intended.	
10:RC Robustness Check	Failure of key system exposes: a) >150 people, or b) >50 people sleeping in firecell c) Detention, Treatment or Care	ASET/RSET with each system failed in turn, except i. Sprinklers & Detection systems,	N/A as no systems to fail

4.4 Challenging fire

Fast t^2 fires will be modelled using B Risk and the ASET/RSET for the tent occupants will be determined. This includes assessment of the escape routes, FED (CO and thermal) and visibility. It assumes that passive and active systems will perform as intended.

Challenging fires are proposed to be located as follows:

- In the circus ring
- Underneath Seating

The proposed design fire locations are shown on the Drawing in Appendix 2.

4.5 C/VM2 Design Fire Scenario Life Safety Rules and Parameters

The following table summarises the Design Fire Scenario modelling rules as applicable to this building:

Rule	Description	Verification Requirement	Proposal
a)	Warning System.	<p>A smoke detection system is not to be installed as agreed by the stakeholders at the FEB meeting for the following reasons:</p> <ul style="list-style-type: none"> • The circus tent is all one large space with focused activity and occupants will be able to see a fire • There is a high level of staff management in the tent • Smoke detection would provide false alarm issues due to the theatrical smoke • Installation of a smoke detection system is difficult for a tent and not able to comply with a standard • There are durability issues of constantly erecting and dismantling a detection system weekly 	<p>Manual call points are to be provided at the sound box and at back of stage. These are to set off sounders in the circus tent.</p> <p>The sound box staff are to turn off the music upon activation of the manual call point system</p>
b)	Fire & Smoke doors:	Assumed closed, unless used for escape:	
		i) Low load: open 3 sec/person for egress.	N/A
		ii) High load: open for duration of queuing.	N/A

c)	Other doors:	Assumed open	N/A
d)	Egress doors:	Assume half-width for smoke flow calculations	Circus tent doors (3 of) assumed open during evacuation
e)	Zone model leakage:	Non-rated walls: model as tall narrow slot. Use a single unit for all wall leakage (B-Risk modelling used)	Leakage greater in a tent than a normal building. It is proposed to model this additional leakage at high level In particular there are leakage paths at the top of the tent in the locations detailed on the drawings in Appendix 2. Venting in the zone model will be used to model this leakage as well as the vents provided by the circus construction eg. Vents that are part of the circus tent doors.
f)	CFD model leakage:	As per Zone model, or 1 vent at floor level & 1 vent at ceiling	N/A (Zone model used)
g)	Leakage areas:	Assumed closed, unless used for escape.	N/A
		i) Smoke doors/separations: zero, except 10mm gap under door	N/A
		ii) Fire doors (not Sm) 10mm gap over height of door.	N/A
		iii) Fire rated construction: zero leakage.	N/A
		iv) Non rated walls: a. Internal: $0.001\text{m}^2/\text{m}^2$ b. External: $0.005\text{m}^2/\text{m}^2$	As per e) above, further leakage proposed
h)	Compliant Smoke separations:	In situ until: Rated temperature or flashover (soonest governs)	N/A
i)	Non-compliant Smoke separations:	In situ until: Upper layer temperature reaches 200°C	N/A
j)	Windows:	Non-rated open at: i) Upper layer temperature reaches 500°C , or ii) Fire becomes ventilation limited.	N/A
		Rated windows: in-situ until rated time	N/A
k)	Fire Location:	$\leq 0.5\text{m}$ FFL	Yes – See Appendix 2 for design fire locations and section 4.4
l)	FED	FED _{CO} : CO, CO ₂ & O ₂	<0.3
		FED _{Thermal} : Radiative & Convective	<0.3
m)	Visibility	Visibility to	>10m

4.6 C/VM2 Design Fire Characteristics: Pre-flashover fires

The following table summarises the Design Fire Characteristics rules as applicable to this building:

Building Use	Fire Growth Rate (kW)	Species	Radiative Fraction	Peak HRR
All buildings (including Storage <3.0m)	Fast αt^2 0.0469t ²	i) $Y_{SOOT} = 0.07\text{kg/kg}$	0.35	20MW
		ii) $Y_{CO} = 0.04\text{kg/kg}$		
		iii) $\Delta H_C = 20\text{MJ/kg}$		
		iv) $Y_{CO_2} = 1.5\text{kg/kg}$		
		v) $Y_{H_2O} = 1.0\text{kg/kg}$		

4.7 B Risk Setup

B Risk is to be used for the challenging fire modelling to provide the Available Safe Egress Time (ASET).

The circus tent is circular however B Risk does not allow for this type of room to be modelled, therefore an equivalent sized square room is to be modelled.

The circus tent has four very high peaks where the four main poles are located, these provide four narrow high volumes for smoke to fill. There is also a high point in the centre above the lighting rig. A sloping roof will be modelled in B Risk to a similar volume to that provided in the actual circus tent. Appendix 2 details further the actual situation compared to the proposed B Risk set-up.

There are a variety of vents provided in the tent which are further detailed in Appendix 2. These will be modelled in B-Risk as ceiling vents and leakage.

5 Movement of People

5.1 Occupant Loads

The occupant loads for the tent are based upon the proposed seating. The new seating is proposed to allow 690 occupants. If however this design shows that this occupancy is not possible the seating will be adjusted to suit. The order to purchase the seating from Ulrich Aluminium is currently on hold awaiting the outcome of this design.

5.2 Detector Criteria

As discussed at the FEB meeting, visual detection as allowed by C/VM2 would be the main form of detection if a fire should the fire occur in the circus ring. Manual alarms would then be activated by circus staff.

5.3 Notification time

As per C/VM2, an alarm notification time of 30 seconds applies to the ASET/RSET calculations.

5.4 Pre-travel activity times

The pre-travel activity times used for the ASET/RSET calculations are as follows:

Description of Building Use	Pre Travel Time
Spaces within buildings which have only focused activities (eg, cinemas, theatres and stadiums) Space of origin (occupants assumed to start evacuation travel immediately after detection and notification time or when fire in their space reaches 500 kW, whichever occurs first)	0s

5.5 Travel times

The travel time assessment will be based on the greater of the travel time or the flow time as determined from the appropriate calculations as per C/VM2. It is expected that flow time will govern.

The owner advised that the tent flap doors have a clear width of 3.4m to a 1.8m head height. Above that the tent flap joins at the centre at a height of 3.4m. The effective width will be calculated using the standard boundary layer conditions in C/VM2.

50% of the occupants will be assessed to be travelling through the primary exit. The rest of the occupants will be distributed between the other two public exits. The back stage exit will not be used by the public.

6 Miscellaneous

The circus tent doors are not typical doors. They are 3.4m wide tent flaps which are made up of two flap openings. The openings are secured for bad weather using 'lacing'. This is a special knotting system that once pushed on, it releases easily and access is available through the tent flap. Photos of the system are shown in the Appendix.

The power system in the building can be made up of a combination of mains power and a generator. The main circus tent lighting can be provided by a combination of the generator and the mains power. The owner intends to also provide emergency lighting in the building using stand alone battery back up fittings.

Exit signage is currently provided at all of the exits, these are illuminated exit signs. These signs are turned on (illuminated) prior to each performance starting. Where necessary further exit signage is to be provided for F8 compliance.

The seating is located on the tiered chquer plate flooring which is proposed to extend to a 2m height as per the 3D drawings in Appendix 1. Given this flooring is unrated no storage is to occur beneath it. This includes the staff BBQ, diesel heater etc..

The seating layout and design is required to comply with the requirements for seating size, aisles etc. in C/AS4. The seating is joined together with four in a row. As discussed at the FEB meeting the owner is investigating the ability to fix the seats which are located at the ends of the aisles to the flooring. The order to purchase the seating from Ulrich Aluminium is currently on hold awaiting the outcome of this design.

Released Under the
Official Information Act 1982

7 APPENDIX 1 – Drawings and Photos and other relevant info

Released Under the
Official Information Act 1982



Ground Plan

1. These drawings are to be read in conjunction with the Design Advice by OnFire Consulting Ltd.
2. These drawings are intended to support the fire report, they do not show all of the required fire safety features in the report and are not detailed construction drawings.

Key

FEB Issue

these caravans and small open sided tent not reviewed

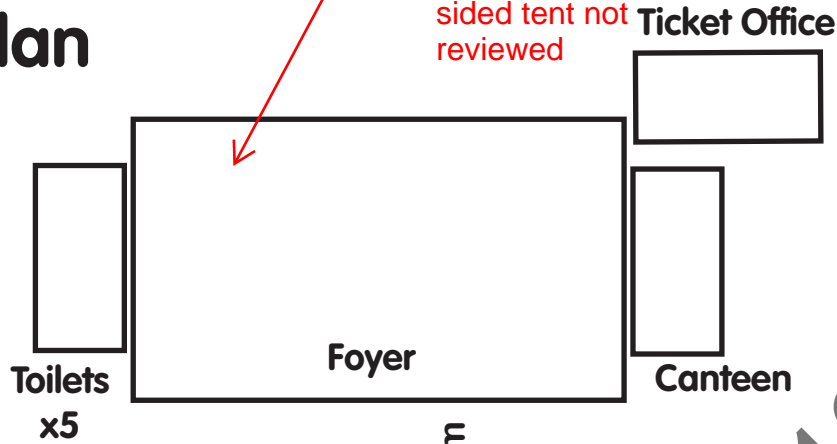

Locations of Ticket office, Canteen, Toilets, and Foyer may vary slightly depending on individual grounds

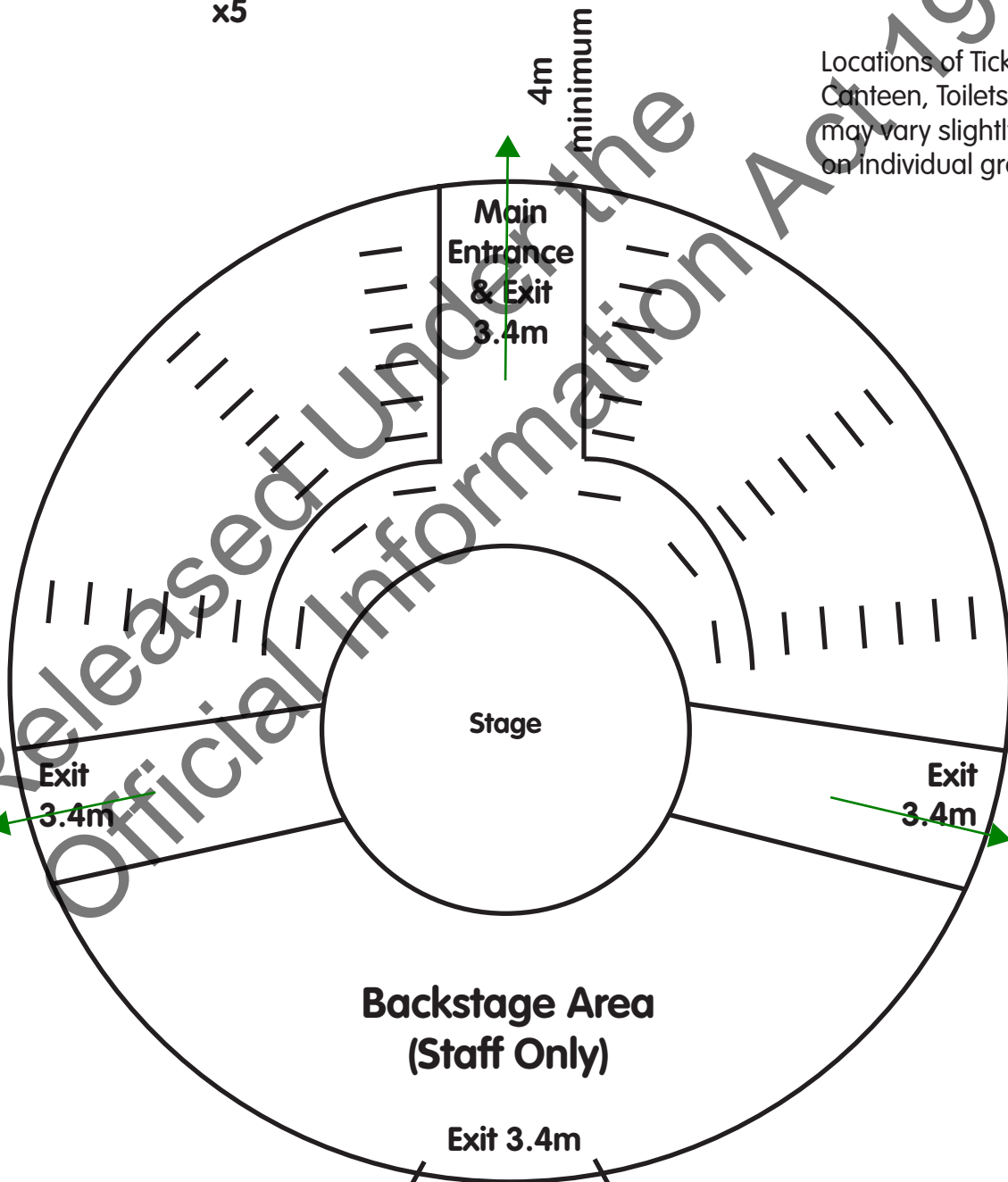

Circus Tent, 35m diameter

Released Under the Official Information Act 1982



Ground Plan

ONFIRE

Job Number: 1942

Date: 14 June 2013

1. These drawings are to be read in conjunction with the Design Advice by OnFire Consulting Ltd.

2. These drawings are intended to support the fire report, they do not show all of the required fire safety features in the report and are not detailed construction drawings.

Key

FEB Issue

Front
(Main Entrance)

King Poles (10m)

Stage (12m)

Tent Centre

Emergency 1

Emergency 2

Rear
(Artists Entrance)

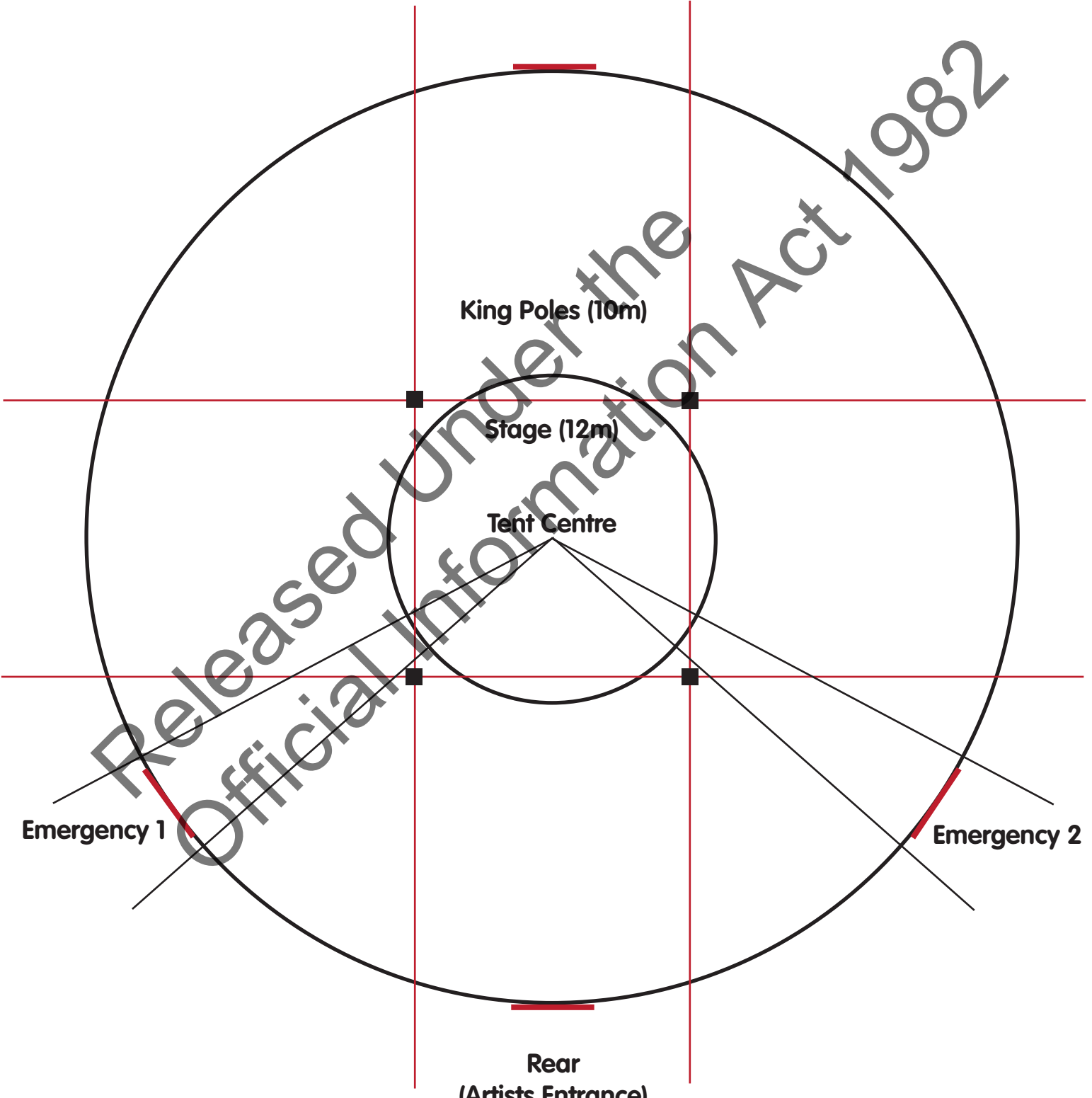

Job Number: 1942
Date: 14 June 2013

1. These drawings are to be read in conjunction with the Design Advice by OnFire Consulting Ltd.
2. These drawings are intended to support the fire report, they do not show all of the required fire safety features in the report and are not detailed construction drawings.

Key

FEB Issue

EXIT 4

EXIT 3

EXIT 2

1 2 3 4 5 6 7 8 9 10 11

35000 # OF TENT

EXIT 1

Bespoke Seating layout
as designed for Zirka Circus by
Ullrich Aluminium

Rows 1 and 2 VIP/ Ringside
up to 90 seats

Rows 3 -11 Elevated
up to 600 seats

Released under the
Official Information Act 1982

ZIRKA CIRCUS 24 SECTION STADIUM DESIGN

ONFIRE

Job Number: 1942

Date: 14 June 2013

1. These drawings are to be read in conjunction with the Design Advice by OnFire Consulting Ltd.

2. These drawings are intended to support the fire report, they do not show all of the required fire safety features in the report and are not detailed construction drawings.

Key

FEB Issue

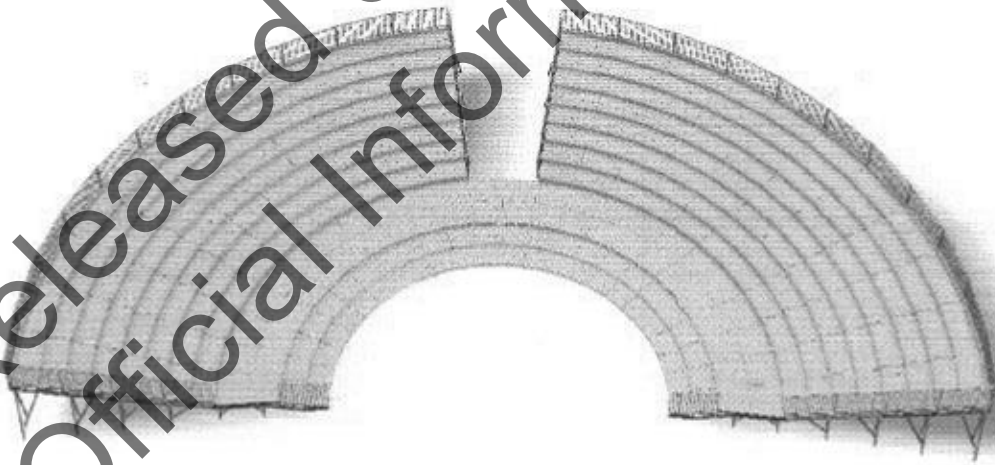
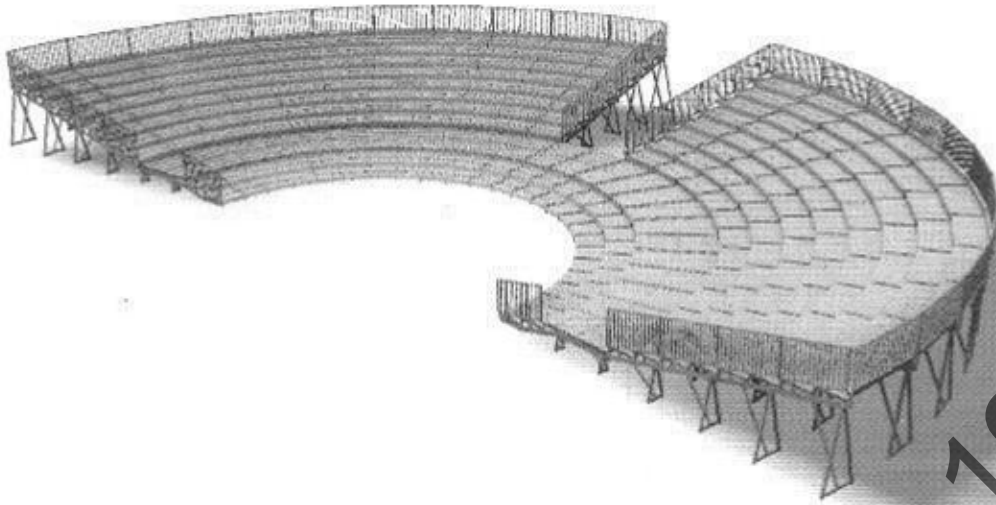

Released Under the
Official Information Act 1982

ZIRKA CIRCUS 24 SECTION STADIUM DESIGN

ONFIRE

Job Number: 1942
Date: 14 June 2013

1. These drawings are to be read in conjunction with the Design Advice by OnFire Consulting Ltd.
2. These drawings are intended to support the fire report, they do not show all of the required fire safety features in the report and are not detailed construction drawings.

Key

FEB Issue

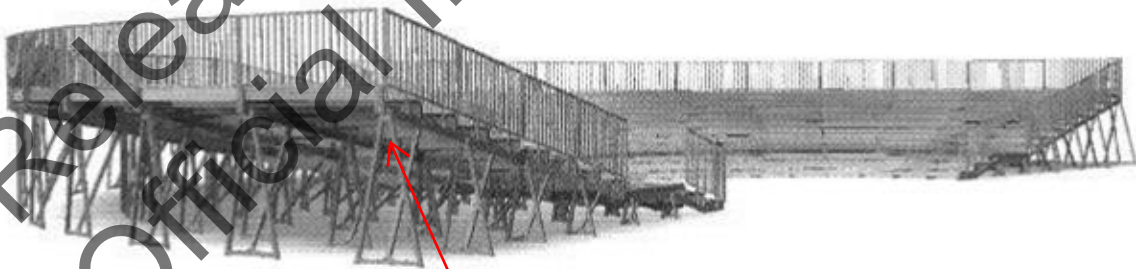

maximum 2m
height

Released Under the
Official Information Act 1982

ZIRKA CIRCUS 24 SECTION STADIUM DESIGN

ONFIRE

Job Number: 1942
Date: 14 June 2013

1. These drawings are to be read in conjunction with the Design Advice by OnFire Consulting Ltd.
2. These drawings are intended to support the fire report, they do not show all of the required fire safety features in the report and are not detailed construction drawings.

Key

FEB Issue

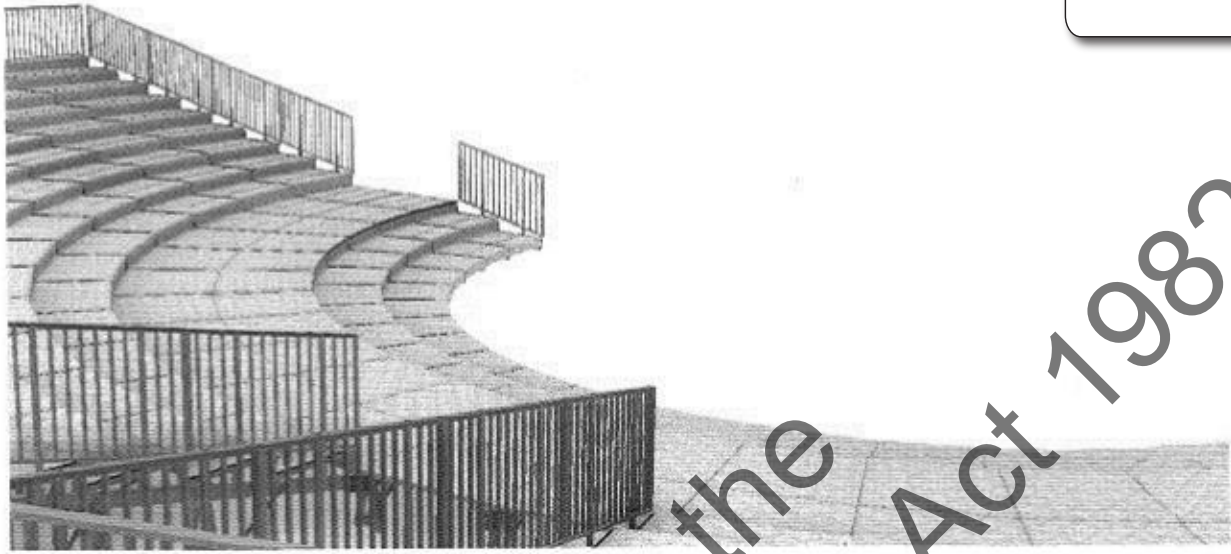

Released Under the
Official Information Act 1982

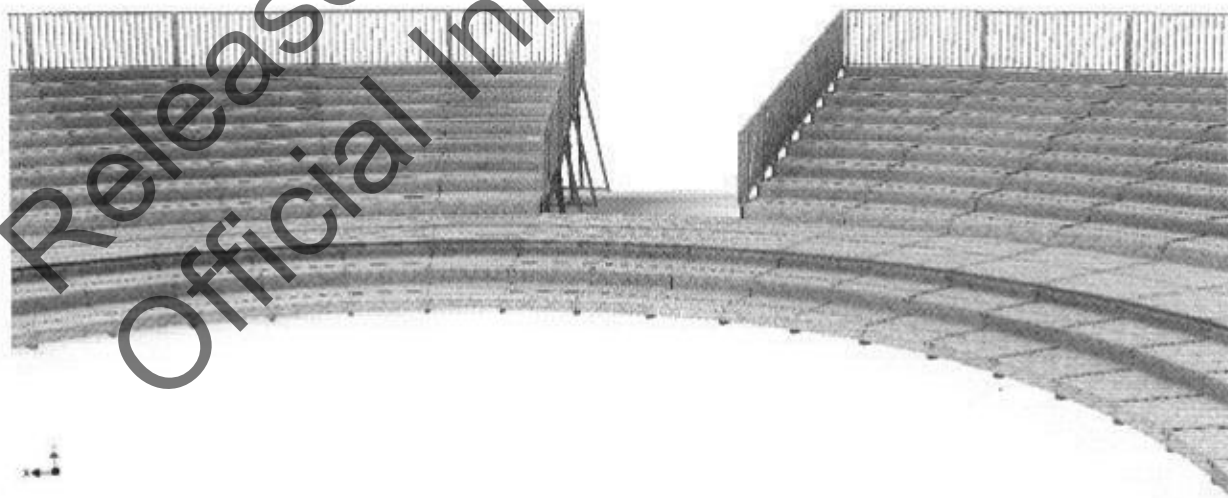



Evacuation Plan for Circus Marquee

increasing to
690 with
proposed new
seating

Capacity of Marquee 495 Max (including Staff)

Average capacity 250

Wardens/Ushers are responsible for the orderly evacuation of Patrons in the case of any emergency.

Four main designated exit areas –

Exit 1 Main Entrance

For the Evacuation of patrons in centre wedge of elevated seating to the immediate left and right of main Exit and VIP seating directly in front of Exit.

Exit 2 Stage Right

For evacuation of ringside and VIP seats in right hand half of Marquee, and elevated seating in the right hand third of Marquee.

Exit 3 Stage Left

For evacuation of ringside and VIP seats in left hand half of Marquee, and elevated seating in the left hand third of Marquee.

Exit 4 Backstage

Any staff not involved in evacuation process will exit via Backstage door. There is no public access to the Backstage area.

Two ushers are dedicated to each Exit to ensure the doors are held open. Wardens are dedicated to each “wedge” of seating to ensure patrons exit via closest Exit.

On exiting all patrons will be ushered to main assembly area in front of circus tent by outside staff.

Evacuation procedures coordinated by the designated team under the supervision of the tour manager, Jeni Hou.

For full details see attached Certified Fire Design.

**ONFIRE**

Job Number: 1942

Date: 14 June 2013

1. These drawings are to be read in conjunction with the Design Advice by OnFire Consulting Ltd.
2. These drawings are intended to support the fire report, they do not show all of the required fire safety features in the report and are not detailed construction drawings.

Key

FEB Issue

Zirka Circus Health and Safety Operating Procedures:

During Set up and Pull Down

1. All workplace safety and OSH safety regulations will be observed.
2. Only Zirka Circus staff are permitted within perimeter of set up.
3. Public are welcome to watch (set up is usually on Public Parks or Reserves) but will be kept at least 10m outside Marquee perimeter by staff.

Once Set Up

4. Access areas within Zirka Circus set up will be well lit and accessible for all staff members and public. If sufficient lighting is unavailable portable lighting will be provided.
5. Trip hazards will be identified, isolated, and affected parties will be made aware when appropriate.
6. Fire and evacuation procedures have been adopted in line with Approved Fire Design recommendations and approved when inspected pre show time.
7. Fire extinguishers are located at main points within Zirka Circus set up.
8. Kitchen facilities are set up in accordance to safety/health regulations.
9. Toilets/showers are provided and maintained by Zirka Circus to ensure convenience is met when needed.
10. All grey water/sewage is held in containment tanks until disposal in appropriately certified dump stations.
11. Disposal of Rubbish in Wheelie bins strategically placed around the site ensures a continued "Tidy" appearance and clean and healthy environment. Bins are decanted into a Skip on site.
12. All rubbish generated is disposed of via approved local contractors or at appropriately certified dump stations.

Security Plan

1. Zirka Circus staff undertake all security arrangements.
2. During non-show times, whenever onsite, staff keep watch over facilities.
3. Should security issues arise involving members of public, staff will contact Police should the need arise.

First Aid Plan

1. First Aid kits kept in management caravan and Ticket office and available for general use when required.
2. If located with a locked premises, a relevant gate key will be requested to provide emergency vehicle access.
3. A qualified first aider is always on site.
4. In the event of a first aid emergency, staff will immediately contact relevant Emergency Service, secure the site and ensure staff and patrons are removed from exposure to any further harm.
5. Staff will work with emergency services and injured party as instructed until service arrives.
6. Steps such as ensuring airway is unobstructed, checking pulse, placing in recovery position (if appropriate) will be taken.

Contacts

General Manager: James Finlayson 021 856223
Managing Director: Jeni Hou 027 3205881

Bookings and other enquiries 0800 2 ZIRKA (0800 294752)

AWTA TEXTILE TESTING

Australian Wool Testing Authority Ltd - trading as AWTA Textile Testing
A.B.N. 43 006 014 106
1st Floor, 191 Racecourse Road, Flemington, Victoria 3031
P.O. Box 240, North Melbourne, Victoria 3051
Phone (03) 9371 2400 Fax (03) 9371 2499

TEST REPORT

CLIENT : BAYTEX MANUFACTURING LTD
52 NEWTON STREET
MT MAUNGANUI SOUTH
NEW ZEALAND

TEST NUMBER : 7-552010-BO
DATE : 30/04/2007
ORDER NUMBER : 25430702BT

SAMPLE DESCRIPTION Clients ref: "Ferrari preconstraint 702-CH Big top"
PVC coated fabric
Colour: Yellow/blue
Enduse: Architectural textiles

THESE RESULTS MUST BE CONSIDERED IN CONJUNCTION
WITH THE COMMENTS ON THE FOLLOWING PAGE(S)

Material Specification provided by client:

Nominal composition: PES yarn coated with PVC flame retardant on both sides and varnished
Nominal mass: 830g/m²
Nominal thickness: 064mm

AS/NZS 1530.3 - 1999 Simultaneous determination of Ignitability, Flame Propagation, Heat Release and Smoke Release

RESULTS:

Face tested: Both
Date tested: 27/04/2007

	Mean		Standard Error
Ignition time	4.01	min	0.12
Flame propagation time	22.4	s	1.9
Heat release integral	105.4	kJ/m ²	3.5
Smoke release, log d	0.2503		0.0139
Optical density, d	1.7839	/m	

Number of specimens ignited: 6

Number of specimens tested: 6

REGULATORY INDICES		
Ignitability Index	16	Range 0-20
Spread of Flame Index	9	Range 0-10
Heat Evolved Index	4	Range 0-10
Smoke Developed Index	8	Range 0-10

159805

(CONTINUED NEXT PAGE)

PAGE 1

© Australian Wool Testing Authority Ltd
Copyright - All Rights Reserved



This Laboratory is accredited by the National Association of Testing Authorities, Australia, for:
- Chemical Testing of Textiles & Related Products : Accreditation No. 983
- Mechanical Testing of Textiles & Related Products : Accreditation No. 965
- Heat & Temperature Measurement : Accreditation No. 1356

The tests reported herein have been performed in accordance with its terms of accreditation. Samples, and their identifying descriptions have been provided by the client unless otherwise stated. AWTA Ltd makes no warranty, implied or otherwise, as to the source of the tested samples. The above test results relate only to the sample or samples tested. This document shall not be reproduced except in full and shall be rendered void if amended or altered. This document, the names AWTA Textile Testing and AWTA Ltd may be used in advertising providing the content and format of the advertisement have been approved in advance by the Managing Director of AWTA Ltd.



Baytex Manufacturing Co. Ltd.

0204/5/05

Jandolai
APPROVED SIGNATORY

Michael A. Jackson
MICHAEL A. JACKSON B.Sc (Hons)
MANAGING DIRECTOR

AWTA TEXTILE TESTING

Australian Wool Testing Authority Ltd – trading as AWTA Textile Testing
A.B.N. 43 006 014 106
1st Floor, 191 Racecourse Road, Flemington, Victoria 3031
P.O. Box 240, North Melbourne, Victoria 3051
Phone (03) 9371 2400 Fax (03) 9371 2499

TEST REPORT

ONFIRE

Job Number: 1942
Date: 14 June 2013
1. These drawings are to be read in conjunction with the Design Advice by OnFire Consulting Ltd.
2. These drawings are intended to support the fire report, they do not show all of the required fire safety features in the report and are not detailed construction drawings.
Rev

FEB Issue

CLIENT : BAYTEX MANUFACTURING LTD
52 NEWTON STREET
MT MAUNGANUI SOUTH
NEW ZEALAND

TEST NUMBER : 7-552010-BO
DATE : 30/04/2007
ORDER NUMBER : 25430702BT

Comments:

These results only apply to the specimen mounted, as described in this report.

The results of this fire test may be used to directly assess fire hazard, but it should be recognized that a single test method will not provide a full assessment of fire hazard under all fire conditions.

The specimens were mounted to simulate use in an unsupported or free hanging mode. The results may be significantly different when mounted to simulate a wall cladding or upholstery application.

To allow free movement of sample during testing all corners were folded away from the clamps.

Each test specimen was sandwiched between two layers of galvanised welded square mesh made from wire of nominal diameter 0.8mm and nominal spacing of 12mm in both directions, stapled through at four points, each 100mm from the centre of the sample and the assembly clamped in four places.

159805

(CONTINUED NEXT PAGE)

PAGE 2

© Australian Wool Testing Authority Ltd
Copyright - All Rights Reserved



This Laboratory is accredited by the National Association of Testing Authorities, Australia, for:
- Chemical Testing of Textiles & Related Products : Accreditation No. 983
- Mechanical Testing of Textiles & Related Products : Accreditation No. 985
- Heat & Temperature Measurement : Accreditation No. 1356

The tests reported herein have been performed in accordance with its terms of accreditation. Samples, and their identifying descriptions have been provided by the client unless otherwise stated. AWTA Ltd makes no warranty, implied or otherwise, as to the source of the tested samples. The above test results relate only to the sample or samples tested. This document shall not be reproduced except in full and shall be rendered void if amended or altered. This document, the names AWTA Textile Testing and AWTA Ltd may be used in advertising providing the content and format of the advertisement have been approved in advance by the Managing Director of AWTA Ltd.



Baytex Manufacturing Co. Ltd.

0204/5/05

APPROVED SIGNATORY

MICHAEL A. JACKSON B.Sc. (Hons)
MANAGING DIRECTOR

Job Number: 1942
 Date: 14 June 2013
 1. These drawings are to be read in conjunction with the Design Advice by OnFire Consulting Ltd.
 2. These drawings are intended to support the fire report, they do not show all of the required fire safety features in the report and are not detailed construction drawings.
 Kev

FEB Issue

AWTA TEXTILE TESTING

Australian Wool Testing Authority Ltd – trading as AWTA Textile Testing
 A.B.N. 43 006 014 106
 1st Floor, 191 Racecourse Road, Flemington, Victoria 3031
 P.O. Box 240, North Melbourne, Victoria 3051
 Phone (03) 9371 2400 Fax (03) 9371 2499

TEST REPORT

CLIENT : BAYTEX MANUFACTURING LTD
 52 NEWTON STREET
 MT MAUNGANUI SOUTH
 NEW ZEALAND

TEST NUMBER : 7-552010-BO
 DATE : 30/04/2007
 ORDER NUMBER : 25430702BT

AS 1530.2-1993

Test for Flammability of Materials

DATE TESTED:

Flammability Index: 5 Range 0 - 100 for most material

19/04/2007

Length Width

Spread Factor: Range 0 - 40	4	3	
Heat Factor: Range 0 - upward	1	1	
Maximum height (h) mean	4.6	4.3	%
cv	10.7	17.4	%
Time (t) mean	N/A	N/A	s
cv	N/A	N/A	%
Heat (a) mean	2.1	2.0	degC min
cv	9.8	0	%
No of specimens tested	6	6	

These test results relate only to the behaviour of the test specimens of the material under the particular conditions of the test, and they are not intended to be the sole criterion for assessing the potential fire hazard of the material in use

159805

PAGE 3

© Australian Wool Testing Authority Ltd
 Copyright - All Rights Reserved



This Laboratory is accredited by the National Association of Testing Authorities, Australia, for:
 - Chemical Testing of Textiles & Related Products : Accreditation No. 983
 - Mechanical Testing of Textiles & Related Products : Accreditation No. 985
 - Heat & Temperature Measurement : Accreditation No. 1356

The tests reported herein have been performed in accordance with its terms of accreditation. Samples, and their identifying descriptions have been provided by the client unless otherwise stated. AWTA Ltd makes no warranty, implied or otherwise, as to the source of the tested samples. The above test results relate only to the sample or samples tested. This document shall not be reproduced except in full and shall be rendered void if amended or altered. This document, the names AWTA Textile Testing and AWTA Ltd may be used in advertising providing the content and format of the advertisement have been approved in advance by the Managing Director of AWTA Ltd.



Baytex Manufacturing Co. Ltd.

Jandolax
 APPROVED SIGNATORY

Michael A. Jackson
 MICHAEL A. JACKSON B.Sc.(Hons)
 MANAGING DIRECTOR



looking from main entry into circus ring and then towards back of stage



Released Under the
Official Information Act 1982

old seating
arrangement



sound/lighting/observer box
beside main entry

Released Under the
Official Information Act 1982



EXIT

one of the exits

Released Under the
Official Information Act 1982



EXIT

Released Under the
Official Information Act 1982

typical tent flap door showing lacing
and exit signage

close up showing 'lacing' of tent doors
to enable quick pushing open and exit

Released Under the
Official Information Act 1982



looking up to the roof of the tent
note two of the four main 'kingpoles'
from which the lighting and prop
structure is supported

Released Under the
Official Information Act 1982



back stage area

Released Under
Official Information Act



photo of the outside showing three of the four main tent poles

the exterior of one of the tent exit door flaps

underneath the existing
seating - heater only used
before performances and
not during

Released by
Official Information



8 APPENDIX 2 – Dimensions, B-Risk Setup and Vents

Released Under the
Official Information Act 1982

TENT FLOOR AREA

35m diameter
Area = 962m²

Equivalent Square Size = 31m x 31m

TENT HEIGHT

Knee height = 4m
Height to bottom of kingpoles = 10.5m
Kingpole height to be ignored

B-Risk Room to be modelled using a sloping roof
between 4m and 10.5m

VENTS

1. Each kingpole (4 of) has natural venting
2. Each doorway has a triangular vent above it (3 of) once evacuation has started
3. Vent around the cupola (central structural piece at the top/centre of the tent)
4. Tent seams (2 of) 33m long, conservatively 15mm wide
5. Gap at top of side walls around the entire perimeter - conservatively 20mm wide

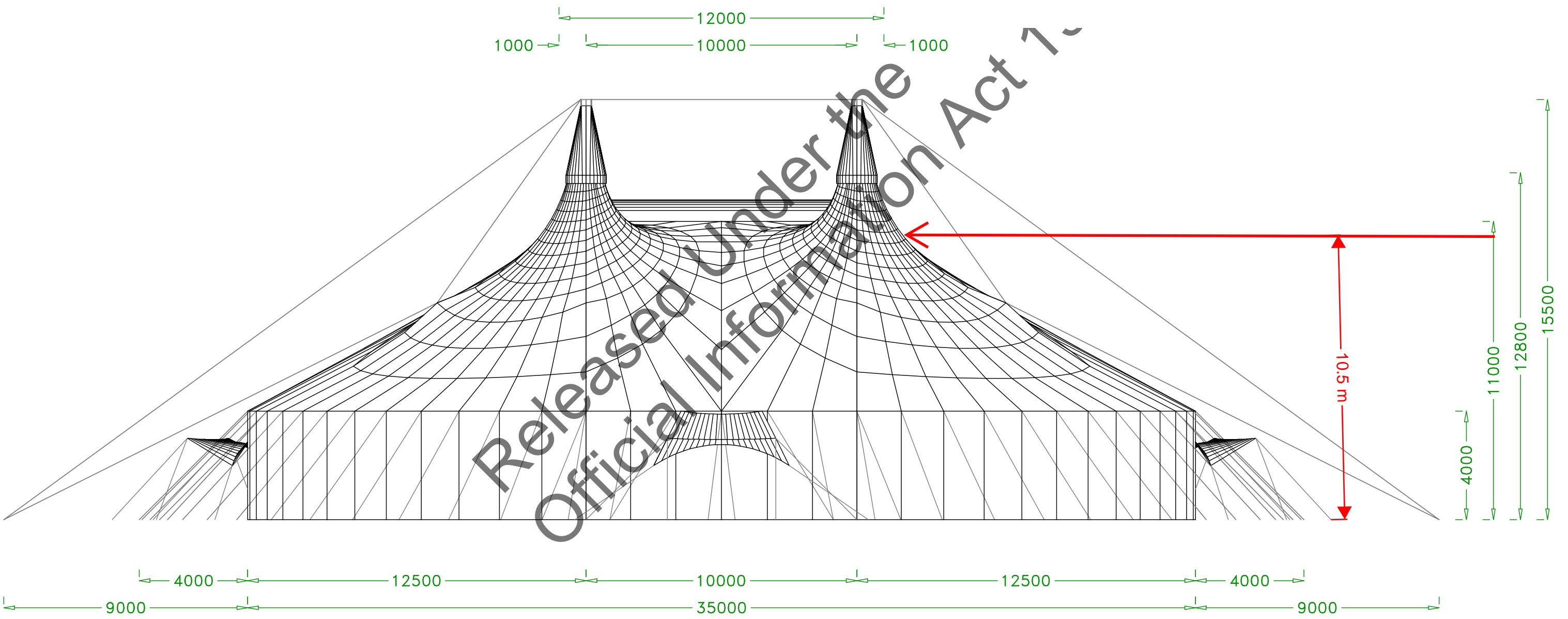

27 APPENDIX 7 – Drawings

Released Under the
Official Information Act 1982

- 1) These drawings are to be read in conjunction with the Design Advice by OnFire Consulting Ltd.
- 2) These drawings are intended to support the fire report, they do not show all of the required fire safety features in the report and are not detailed construction drawings

Drawn: M. Andhe Date: 31/07/13
 Sheet: Floor Plans
 Issue: Fire Safety Design

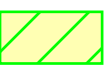
- Key**
-  Required illuminated exit sign, indicative locations to F8/AS1
 -  Required new emergency lighting coverage to F6/AS1

Project Title
 Zirka Circus
 Fire Safety Design

Job No.
 1942

Issue
 1

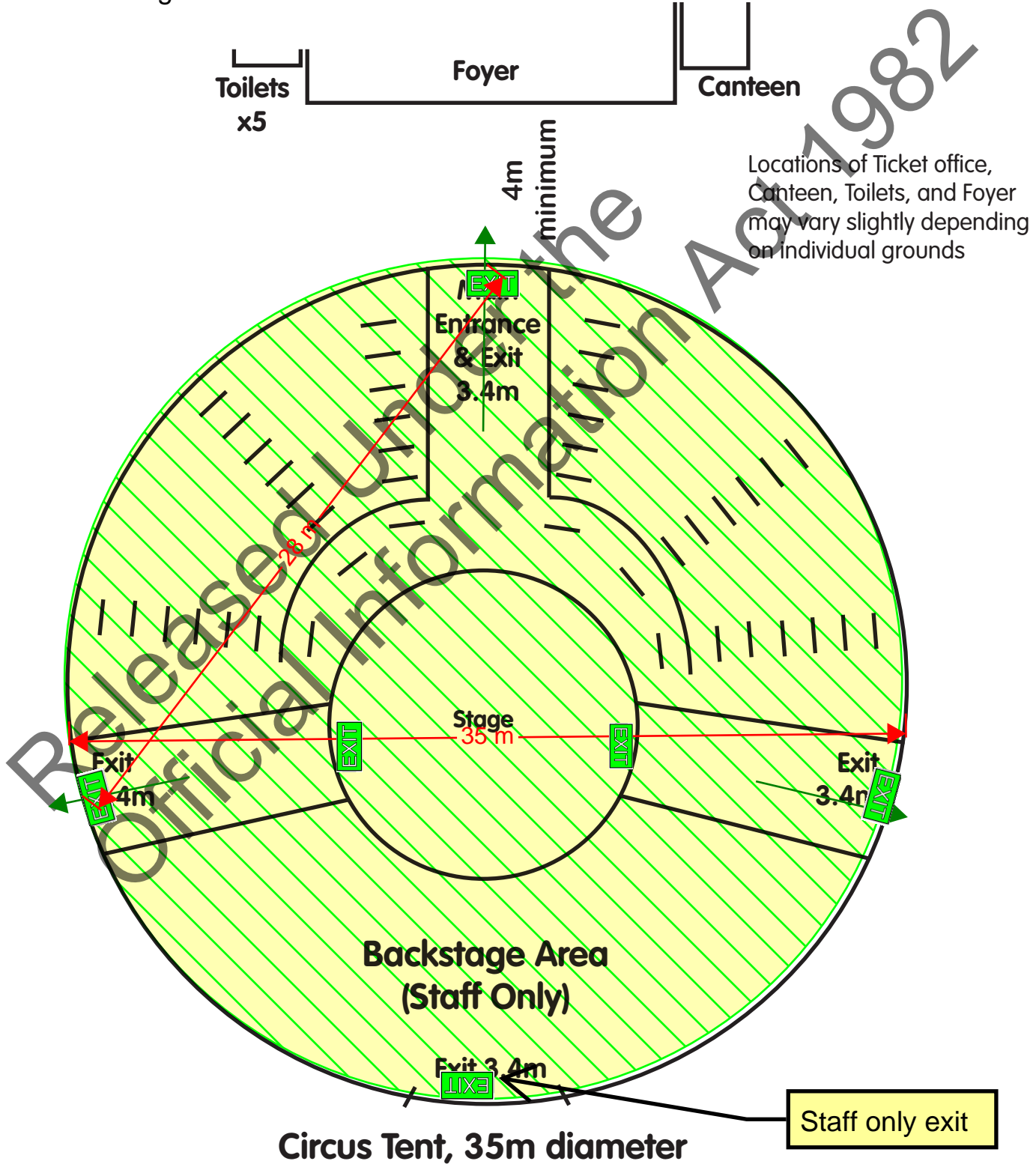

Emergency Light Positions

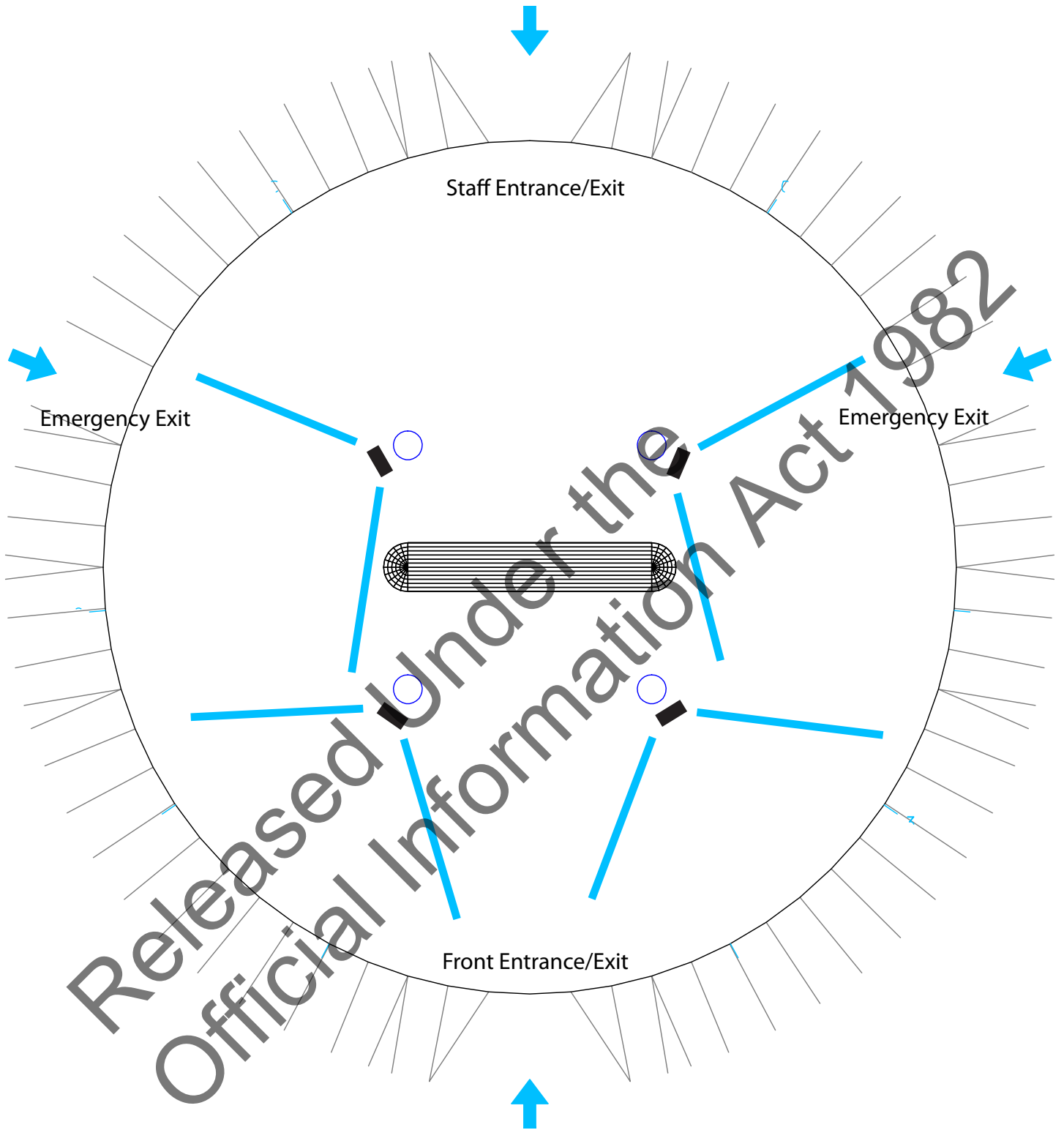

Search

Shop Online

- > LED Lighting
- > ShineWe LED Bulbs
- > Interior Light Fittings
- > Exterior Light Fittings
- > Garden Light Fixtures
- Hunza Lighting World's best Landscape and Exterior Lighting
- > Commercial Lighting
- > **Emergency Lighting**
 - Emergency Exit Lights
 - Emergency Fluorescent Lighting
 - Emergency Ceiling Lights
 - Emergency Floodlights**
 - Light Bulbs/Lamps
 - Transformers 12 volt Halogen

Emergency Lighting > Emergency Floodlights > 10 Watt Emergency Flood



NZ \$299.00
incl GST

Qty

[\\$ Convert currency](#)

[Zoom Image](#)

[Product query](#)

01707

10 Watt Emergency Flood

The M+HBardic Twin Halogen Floodlight emergency luminaire is designed to provide emergency lighting to large high ceiling areas, such as factories and warehouses.

The unit uses 2 x 10 Watt halogen spotlights.

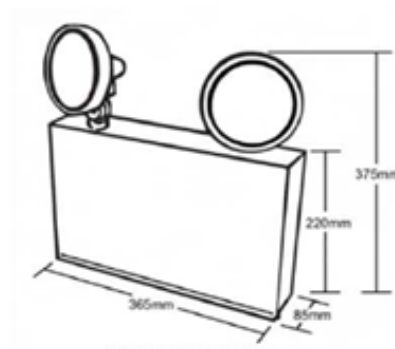

Features include:

- Designed and tested to comply with AS/NZS 2293
- Automatic battery low cut out to prevent over discharge of the battery
- Available with Sealed Lead Acid or NiCad Batteries
- 8 minutes "off" delay – the luminaire remains illuminated for 8 minutes following restoration of the AC mains supply to allow High Bay lights to strike
- High temperature components for extended life
- Red LED indicates a healthy AC mains supply and functioning charger
- Test switch to test the emergency operation while AC mains supply is healthy

Re
Office

28 APPENDIX 8 - CORRESPONDENCE EMAILS

Released Under the
Official Information Act 1982



Mell Quigley <admin@onfire.co.nz>

Re: Exemption for Kawerau

2 messages

Debbie Scott <debbie@onfire.co.nz>

Wed, Jun 12, 2013 at 5:54 PM

To: James Finlayson <james@zirkacircus.com>

Cc: shayh@whakatane.co.nz, Mell Quigley <admin@onfire.co.nz>

Hi Shay

I understand that you've been talking to Zirka Circus about a Consent application.

I am in the process of working with Zirka to design the circus tent to the new Code C1-C6. I am doing this through MBIE as the peer reviewer as Zirka intend on applying for the Multi-proof application through them to enable their Consents to be easier in the future.

As I'm sure you'll understand this will take some time and we are only at the FEB part of the process. I visited the tent a month or so ago when it was at The Base in Hamilton and did an inspection and spoke to James Finlayson. We have also held a FEB meeting with the NZFS and MBIE in Auckland and I'm in process of updating the FEB report for their acceptance.

Other Council people in the past have been concerned with the tent flap/egress doors being tied together. I admit I was also concerned with this and didn't like the idea. However after visiting the tent I was very impressed with the way these doors open. The way they are tied together is called 'lacing' and its very clever and as soon as you push on it they open once the first knot is undone. The biggest issue with them is that this lacing is first knot whilst the tent is unoccupied for security reasons. Similar to what you might do if it was velcroed, you would need some locking device to stop anybody opening them at night time. Security locks are allowed by the compliance docs when buildings are unoccupied. The circus need, and have, a procedure in place to ensure that these doors are un-knotted (with lacing still in place) prior to the public occupying the tent. I've asked James to take a video of how the lacing works as its not until you actually see it you see how effective it is. I think it would be easier to open than velcro as it would be some industrial strength velcro that would be required to hold them heavy tent fabric I suspect.

I hope this explains where I'm at with it, as I said above its still early days with doing the new Code design but Zirka are aware they have to do it and we are working on it as fast as possible.

Please call if you have any queries.

Debbie Scott

Principal Fire Engineer

BE Hons, ME Dist. (Fire), FIPENZ, CPEng, PMSFPE



OnFire Consulting Limited

477 Alexandra Street

PO Box 226

Te Awamutu 3840

P. 07 870 6411

F. 07 870 6412

M. 0274 394 232

www.onfire.co.nz

On Tue, Jun 11, 2013 at 1:34 PM, James Finlayson <james@zirkacircus.com> wrote:

Hi Debbie

Our application for Kawerau is currently being processed.

I wonder if it is possible for you to forward the same email you sent to the people in Tokoroa, to Shay in Whakatane?

His email is shayh@whakatane.co.nz

Thanks very much

Regards

James

--

James Finlayson
General Manager
Flaming Phoenix Entertainment Ltd (Zirka Circus)

www.zirkacircus.com

021 856223

Debbie Scott <debbie@onfire.co.nz>
To: Mell Quigley <admin@onfire.co.nz>

Thu, Jun 13, 2013 at 10:02 AM



Debbie Scott

Principal Fire Engineer

BE Hons, ME Dist. (Fire), FIPENZ, CPEng, PMSFPE

ONFIRE

OnFire Consulting Limited

477 Alexandra Street

PO Box 226

Te Awamutu 3840

P. 07 870 6411

F. 07 870 6412

M. 0274 394 232

www.onfire.co.nz

----- Forwarded message -----

From: **Debbie Scott** <debbie@onfire.co.nz>

Date: Thu, Jun 13, 2013 at 9:32 AM

Subject: Re: Exemption for Kawerau

To: Shay Harrop <Shay.Harrop@whakatane.govt.nz>

Cc: "james@zirkacircus.com" <james@zirkacircus.com>, "dean@zirkacircus.com"

<dean@zirkacircus.com>, "Meagan Edhouse (Meagan.Edhouse@kaweraudc.govt.nz)"

<Meagan.Edhouse@kaweraudc.govt.nz>, Geoff Winship <Geoff.Winship@whakatane.govt.nz>

Hi Shay

Please see my comments inserted in red below.

Kind Regards

Debbie



Debbie Scott
Principal Fire Engineer
BE Hons, ME Dist. (Fire), FIPENZ, CPEng, PMSFPE

ONFIRE

OnFire Consulting Limited
477 Alexandra Street
PO Box 226
Te Awamutu 3840
P. 07 870 6411
F. 07 870 6412
M. 0274 394 232
www.onfire.co.nz

On Thu, Jun 13, 2013 at 9:24 AM, Shay Harrop <Shay.Harrop@whakatane.govt.nz> wrote:

Hi Debbie

Thanks for your email I have a good understanding on how the hitch works for the door and can show how to tie it if you like.

As I am sure you understand my problem is accepting the fire compliance as a whole, the fire report provided under the old code even looks like it should have gone to the DRU. **yes I can understand your difficulty, I believe other Councils have given exemptions for Consent on the basis they can't give Consent as we don't yet have the approval from MBIE for the multiproof acceptance as we aren't far enough down the process.** So I guess what I am looking for is enough information to approve on reasonable grounds. **Understand :-)** To do this I think I need a better understanding on what the final requirements are likely to be e.g. will the numbers be limited? **Numbers are likely to be more than what is currently expected at Kawerau, the circus is waiting to order new seating which will provide for more people (up to 690 depending on how my modelling works out).** What type of warning system will be relied upon? **Given the large open space and focussed activity both MBIE and NZFS have provisionally agreed in the FEB meeting to having only manual alarm systems. Similar to what the circus currently have. We will need to provide emergency lighting as part of this new design to meet F6 and James Finlayson is busy designing/organising this. Etc.**

A copy of the notes from the initial FEB and any correspondence with MIBE and the NZFS may assist in giving the ability to head forward on this one. **At this stage I only have an old FEB, its not quite right but I'll stamp DRAFT on it and send to you shortly.**

I understand the circus is proposed to open tomorrow and at this stage I do not have enough information to allow me to issue the building consent and subsequently open for business. I will respond to any response as soon as it received please copy Geoff Winship Geoff.Winship@whakatane.govt.nz into any correspondence encase I get called out of the office.

I hope this helps, feel free to give me a call if you have any queries. Debbie

Kind regards

Shay Harrop | Building Control Officer

WHAKATĀNE DISTRICT COUNCIL | Private Bag 1002 | Whakatāne 3158
Phone 07 306 0500 **Ext** 7552 | **ddi** | **Mobile** 027 600 7921 | **Fax** 07 307 0718
Email Shay.Harrop@whakatane.govt.nz | **Web** www.whakatane.govt.nz

The content of this email is CONFIDENTIAL INFORMATION and may also be LEGALLY PRIVILEGED, intended only for the person named above.

If this email is not addressed to you, you must not use, read, distribute or copy this document.

If you have received this document by mistake, please call us on 0800 WDCICT and destroy the original message. Thank you.

From: Debbie Scott [mailto:debbie@onfire.co.nz]

Sent: Wednesday, 12 June 2013 5:59 p.m.

To: Shay Harrop; James Finlayson

Subject: Fwd: Exemption for Kawerau

[Quoted text hidden]

Released Under the
Official Information Act 1982